

REVISIONS					
ZONE	SYM	DESCRIPTION	DATE	E.M.N. NO.	APPD
	Ø	REL TO PROD	9 DEC 66	RA	

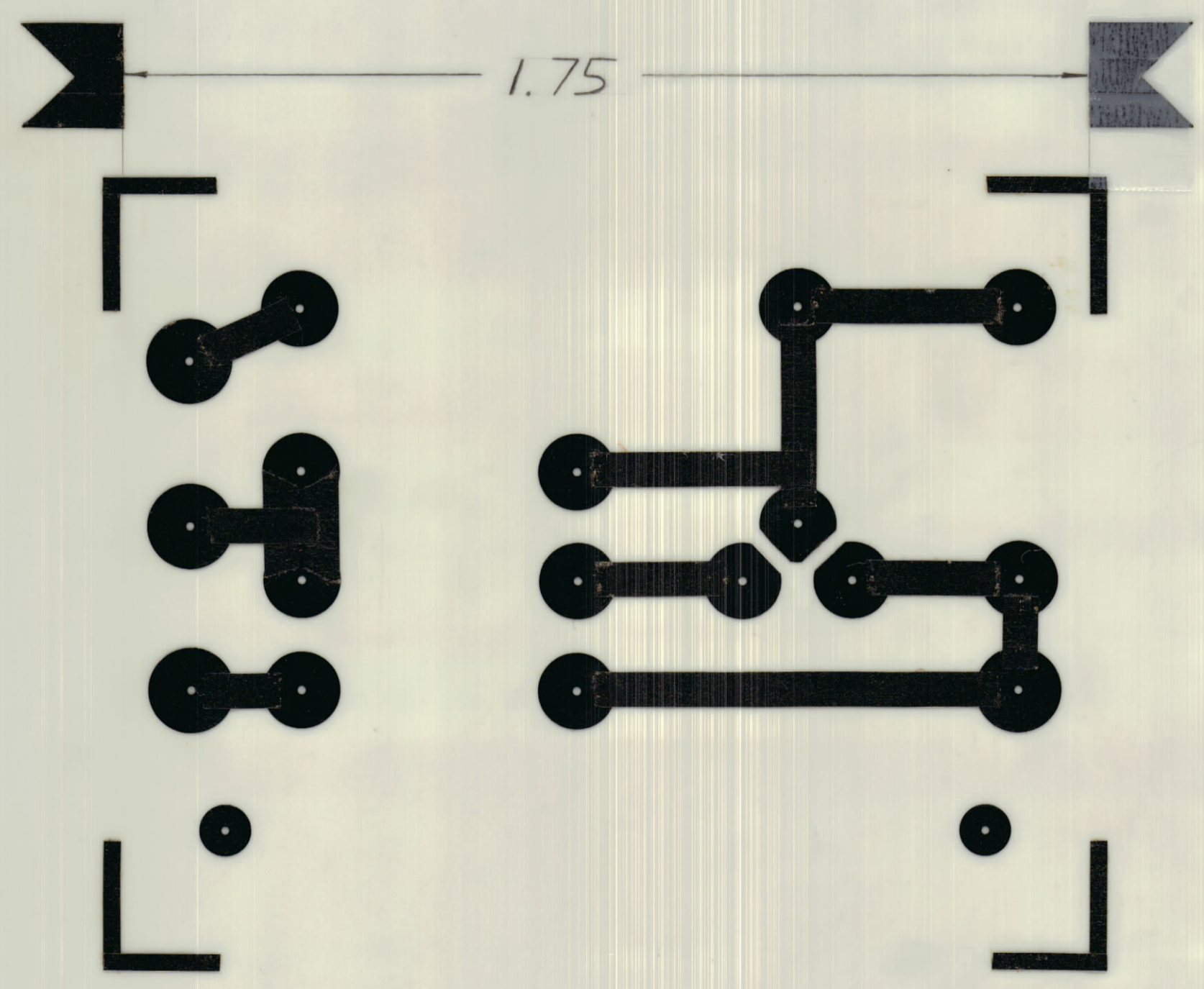

SCALE 4:1  
 NEGATIVE 1:1  
 FOIL SIDE

STE A-1	005/67	A10547-2	7 DEC 66
MODEL	PROJECT NO.	ASS'Y. NO.	DATE
USED ON			

STOCK SIZE		TMC (Canada) LIMITED OTTAWA ONTARIO	
MATERIAL			
WEIGHT PER PC.		ASS'Y PRE AMP. (ETCHING)	
TYPE & TEMPER		RA	
HEAT TREAT. SPEC.			
FINISH & SPEC. NO.		CHECKED	FINAL APPROVAL
		SHEET 1 OF 5 A10547-1 Ø	

IF IT IS FOUND DESIRABLE TO CHANGE ANY TOLERANCE OR OTHER DETAIL SPECIFIED ON THIS DRAWING NOTIFY THE PURCHASER PROMPTLY.		DIMENSIONS IN INCHES UNLESS OTHERWISE SPECIFIED					
MAXIMUM ALLOWABLE TOLERANCES HAVE BEEN DETERMINED AND DEVIATIONS WILL BE CAUSE FOR REJECTION. REMOVE ALL BURRS AND SHARP EDGES.							
ISSUE	ITEM	CHANGED FROM	DATE	CN. NO.	DRAFTS	CHECKER	ENG. APP.
0		REL TO PROD	9 DEC 66		RA		<i>[Signature]</i>

REQ.	ITEM	PART NO.	DESCRIPTION	SYMBOL

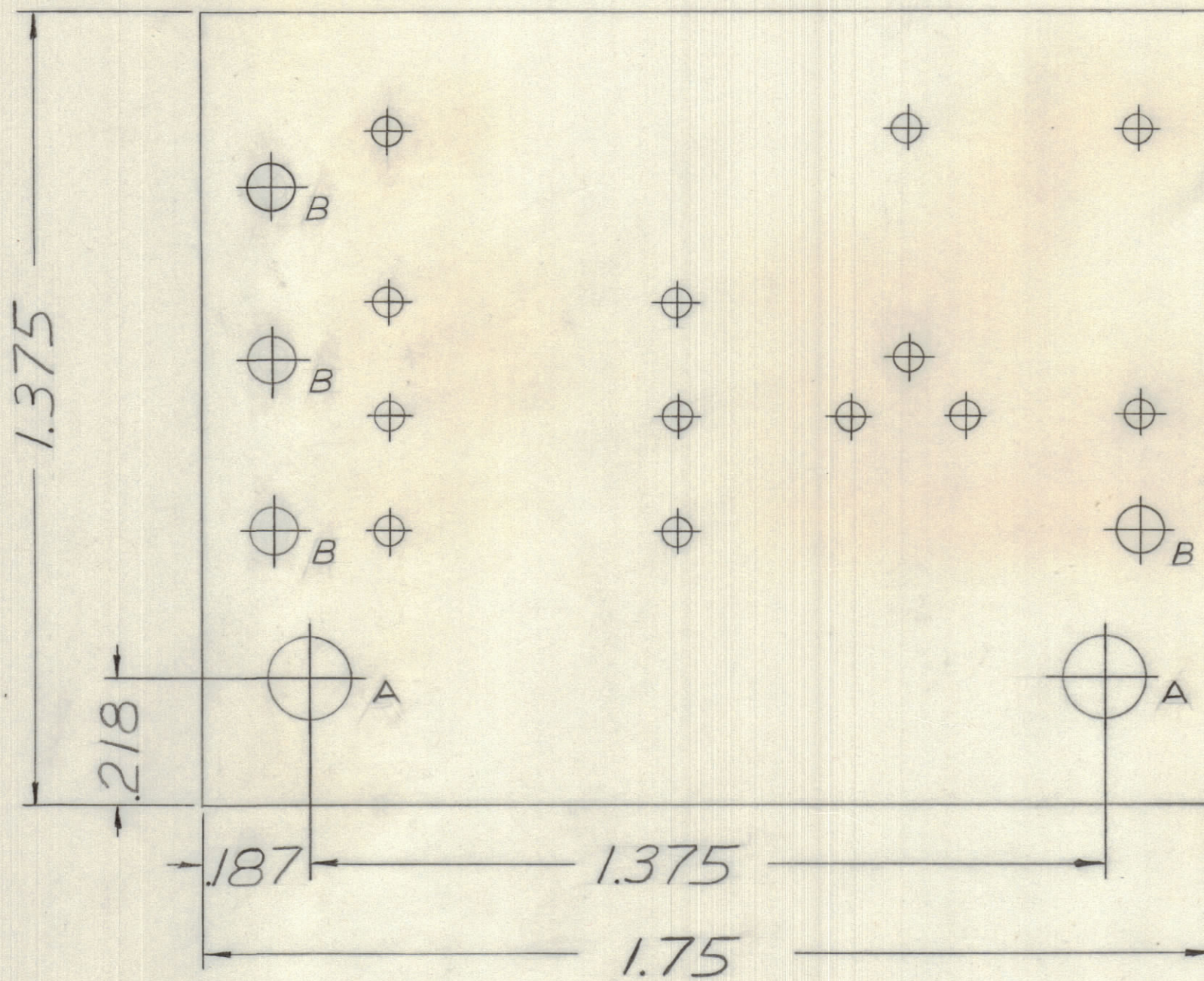

A10547-2  $\phi$

SCALE 4:1  
 NEGATIVE 1:1  
 FOIL SIDE

HOLE	DESCRIPTION	REQ
A	.144 $\pm$ .003 DIA.	2
B	.078 $\pm$ .002 DIA.	4
UNMARKED	.046 DIA.	13

.093		TMC (Canada) LIMITED	
STOCK SIZE		OTTAWA	ONTARIO
EPOXY RESIN 2 OZ CO		ASS'Y PRE AMP.	
MATERIAL		(MACHINING)	
FL-GF093C2		RA	
TYPE & TEMPER		DRAWN	ELEC. DES. APP.
		<i>[Signature]</i>	<i>[Signature]</i>
HEAT TREAT. SPEC.		CHECKED	FINAL APPROVAL
		<i>[Signature]</i>	
FINISH & SPEC. NO.		SHEET 2 OF 5 A10547-2 $\phi$	

TOLERANCES		SCALE: 1:1
ALL OTHERS	DEC. DIM. $\pm$ FRAC. DIM. $\pm$ ANGULAR DIM. $\pm$	DRILL, PUNCH, COMMERCIAL STOCK SIZES AND MANUFACTURERS TOLERANCES ARE NOT INCLUDED.

STE-A-1	005/67	A10547-3	7 DEC 66
MODEL	PROJECT NO.	ASS'Y. NO.	DATE
USED ON			

IF IT IS FOUND DESIRABLE TO CHANGE ANY TOLERANCE OR OTHER DETAIL SPECIFIED ON THIS DRAWING NOTIFY THE PURCHASER PROMPTLY.		DIMENSIONS IN INCHES UNLESS OTHERWISE SPECIFIED					
MAXIMUM ALLOWABLE TOLERANCES HAVE BEEN DETERMINED AND DEVIATIONS WILL BE CAUSE FOR REJECTION. REMOVE ALL BURRS AND SHARP EDGES.							
ISSUE	ITEM	CHANGED FROM	DATE	CN. NO.	DRAFTS	CHECKER	ENG. APP.
0		REL TO PROD	8DEC66		RA		<i>[Signature]</i>

REG.	ITEM	PART NO.	DESCRIPTION	SYMBOL
------	------	----------	-------------	--------

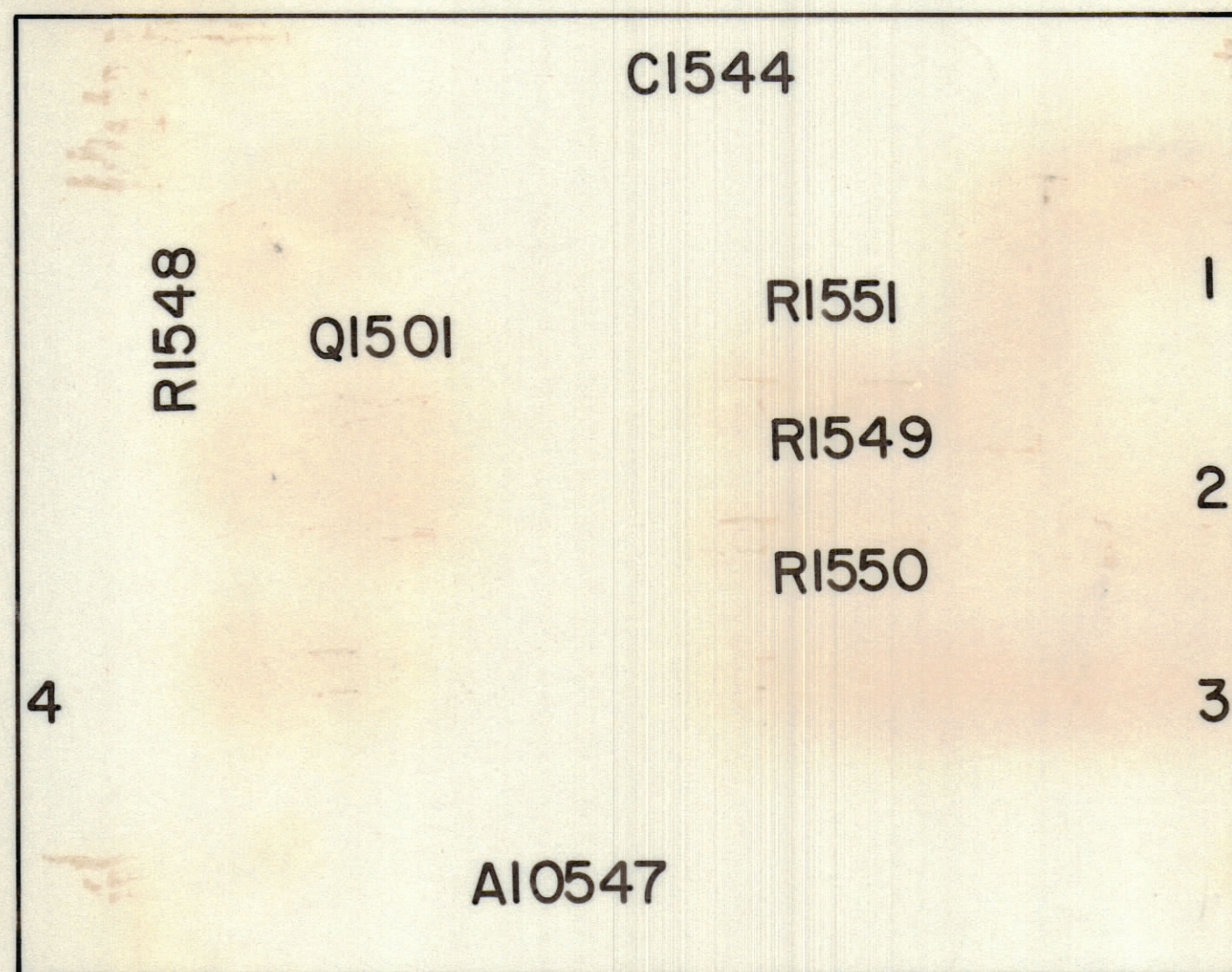

AI0547-3 ∅

LETTERING NOTES:

- 1-LETTERING TO BE WHITE GOTHIC .062 ± .015 / .000
- 2-LINE WIDTH .010 ± .010 / .000
- 3-AS PER TMC SPEC S735

COMPONENT SIDE

TOLERANCES		SCALE: 1:1
ALL OTHERS	DEC. DIM. ± FRAC. DIM. ± ANGULAR DIM. ±	DRILL, PUNCH, COMMERCIAL STOCK SIZES AND MANUFACTURERS TOLERANCES ARE NOT INCLUDED.

STE A-1	500/67	AI0547-4	8DEC 66
MODEL	PROJECT NO.	ASS'Y. NO.	DATE
USED ON			

STOCK SIZE		TMC (Canada) LIMITED OTTAWA ONTARIO	
MATERIAL			
WEIGHT PER PC.		ASS'Y PRE AMP (LETTERING)	
TYPE & TEMPER		RA	
HEAT TREAT. SPEC.		<i>[Signature]</i>	<i>[Signature]</i>
FINISH & SPEC. NO.		CHECKED	FINAL APPROVAL
		SHEET 3 of 5 AI0547-3 ∅	

A10547-4

ISSUE	ITEM	CHANGED FROM	DATE	CN. NO.	DRAFTS	CHECKER	ENG. APP.	REQ.	ITEM	PART NO.	DESCRIPTION	SYMBOL
Ø		REL TO PROD	9 DEC 66		RA		<i>[Signature]</i>	1	1	A10547-3	ASS'Y PRE AMP	
								4	2	TE 127-3	TERMINAL, STUD	

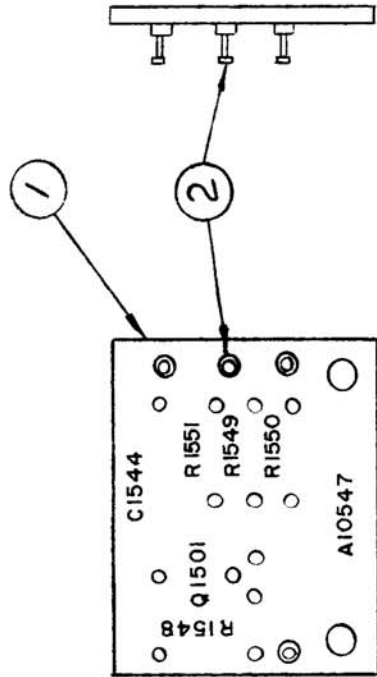

STE A-1		PROJECT NO.	005/66	ASSY. NO.	A10547-4	DATE	8 DEC 66
MODEL		USED ON					
MAXIMUM ALLOWABLE TOLERANCES HAVE BEEN DETERMINED AND DEVIATIONS WILL BE CAUSE FOR REJECTION. REMOVE ALL BURRS AND SHARP EDGES		IF IT IS FOUND DESIRABLE TO CHANGE ANY TOLERANCE OR OTHER DETAIL SPECIFIED ON THIS DRAWING NOTIFY THE PURCHASER PROMPTLY.					
TOLERANCES		SCALE 1:1					
DEC. DIM. ±		DIMENSIONS IN INCHES					
FRAC. DIM. ±		UNLESS OTHERWISE SPECIFIED					
ANGULAR DIM. ±		DRILL, PUNCH, COMMERCIAL STOCK SIZES AND MANUFACTURERS TOLERANCES ARE NOT INCLUDED.					
ALL OTHERS	TOLERANCES ARE NOT INCLUDED.						
STOCK SIZE		MATERIAL		WEIGHT PER PC.		HEAT TREAT. SPEC.	
TYP & TEMPER		TYPE & TEMPER		FINISH & SPEC. NO.		FINISH & SPEC. NO.	
TMC (Canada) LIMITED OTTAWA		ASS'Y PRE AMP		(SUB ASS'Y)		MECH. DES. APP.	
DRAWN		CHECKED		FINAL APPROVAL		MECH. DES. APP.	
RA		<i>[Signature]</i>		<i>[Signature]</i>		SHEET 4 OF 5	
A10547-4		A10547-4		A10547-4		Ø	