

MISSING SYMBOLS

DS9000
R9000

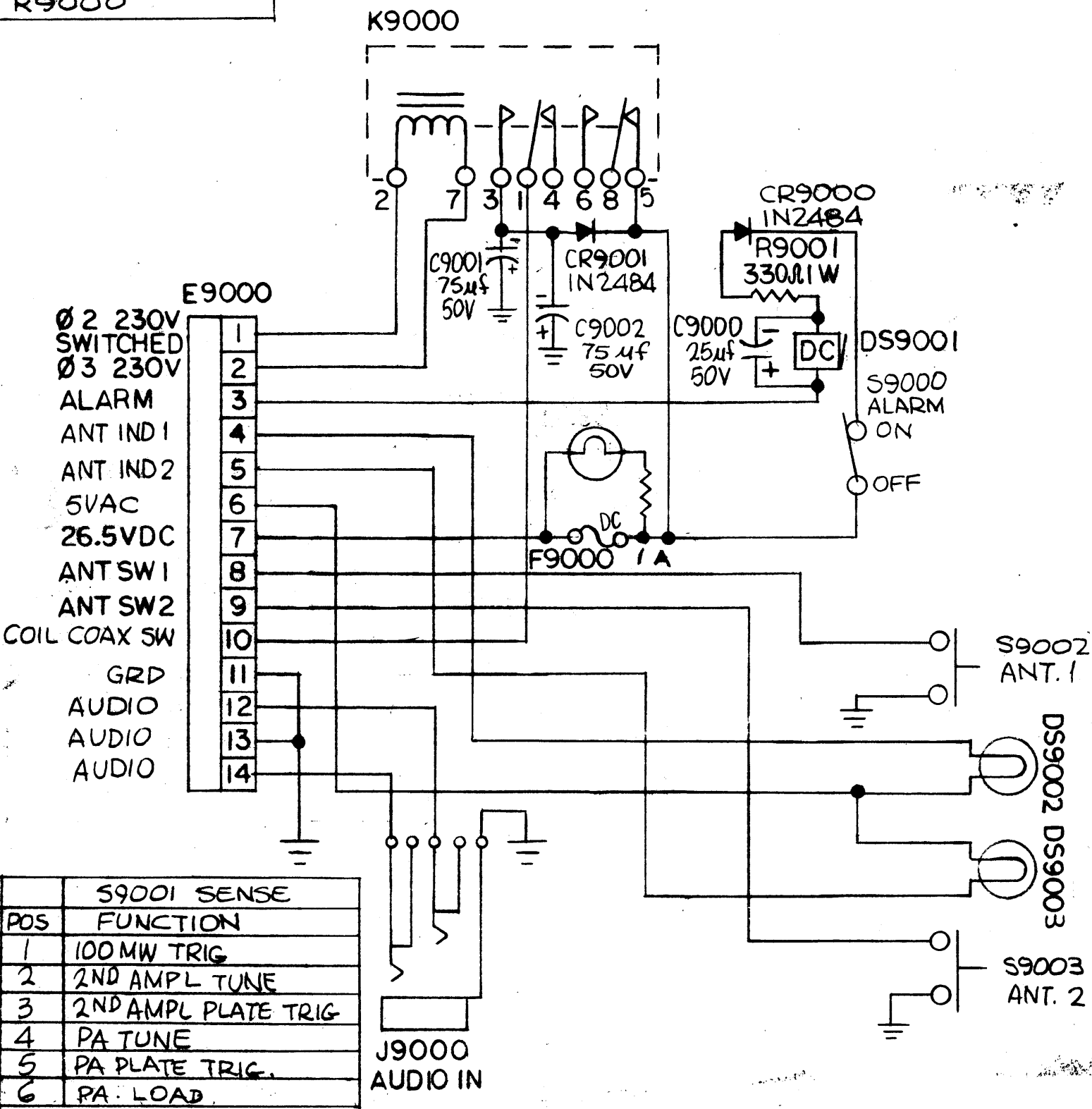

POS	S9001 SENSE FUNCTION
1	100 MW TRIG
2	2ND AMPL TUNE
3	2ND AMPL PLATE TRIG
4	PA TUNE
5	PA PLATE TRIG.
6	PA LOAD

NOTES

1	AX646	
Q'TY./UNIT	MODEL USED ON	ASS'Y. NO.
SCALE	CODE	

THE CONTENTS OF THIS DRAWING ARE THE EXCLUSIVE PROPERTY OF THE TECHNICAL MATERIEL CORP. ITS UNAUTHORIZED USE OR REPRODUCTION IN WHOLE OR IN PART IS STRICTLY FORBIDDEN.

CK1206

REVISIONS					
SYM	DESCRIPTION	DATE	E.M.N. NO.	DRAFT	CHKD
X	EXP RELEASE	9-1-66	X	JBC	HQ
X1	J9003 WAS J9005, CP9000-CP9001 ADDED, P9000-P9001 WERE J9003-J9004	10-4-66	X1	JBC	HQ
X2	C9001, 9002, CR9001 ADDED MISSING SYM. ADDED	12-13-66	X2	JBC	HQ
Ø	ORIGINAL RELEASE FOR PRODUCTION	12/30/66	Ø	RME	
A	SHIELD SYMBOL ADDED J9001 & J9002.	3-7-67	17926	L.A.K.	

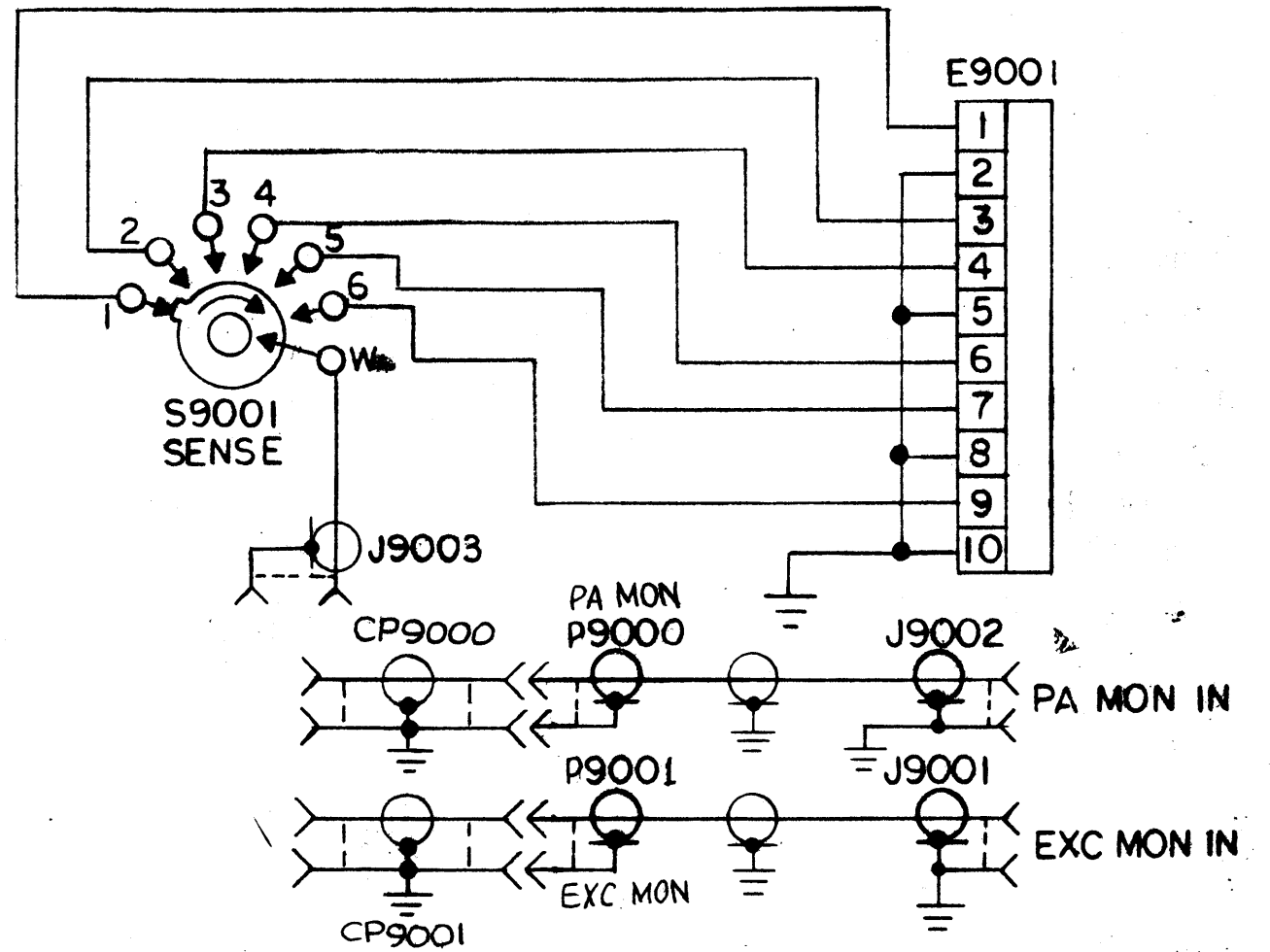

REQ'D.	ITEM	PART NUMBER	DESCRIPTION	SYMBOL
F BUDETTI LIST OF MATERIAL				
MATERIAL			THE TECHNICAL MATERIEL CORP. MAMARONECK, NEW YORK	
FINISH			TITLE SCHEMATIC, MONITOR PANEL	
UNLESS OTHERWISE SPECIFIED DIMENSIONS ARE IN INCHES AND INCLUDE CHEMICALLY APPLIED OR PLATED FINISHES			DRAWN JBC	DATE 9-1-66
DECIMALS .X ± .05 .XX ± .01 .XXX ± .005			CHECKED	DATE
FRACTIONS ± 1/64 ANGLES ± 0 30'			ELE T. DES. JBC	DATE
			MECH. DES. JBC	DATE
			FINAL APPROVAL CK1206	
			DATE 12/30/66	
			SHEET	
			REV. LTR. A	