

MISSING SYMBOLS

DS9000

R9000

CK1207

REVISIONS

SYM	DESCRIPTION	DATE	E.M.N. NO.	DRAFT	CHKD	APPD
X	EXP RELEASE	9-2-66	X	JBC		
X1	J9003 WAS J9005, CP9000 & CP9001 ADDED, P9000 & P9001 WERE J9003 & J9005	10-4-66	X1			
X2	DS9000, R9000 DEL.	12-13-66	X2			
Ø	ORIGINAL RELEASE FOR PRODUCTION	12-30-66	Ø	RME		
A	SHIELD SYMBOL ADDED J9001 & J9002	3-7-67	17926	L.A.K.		

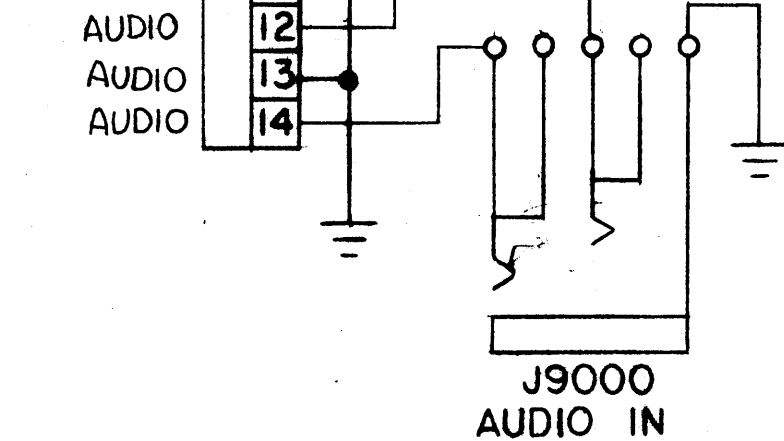
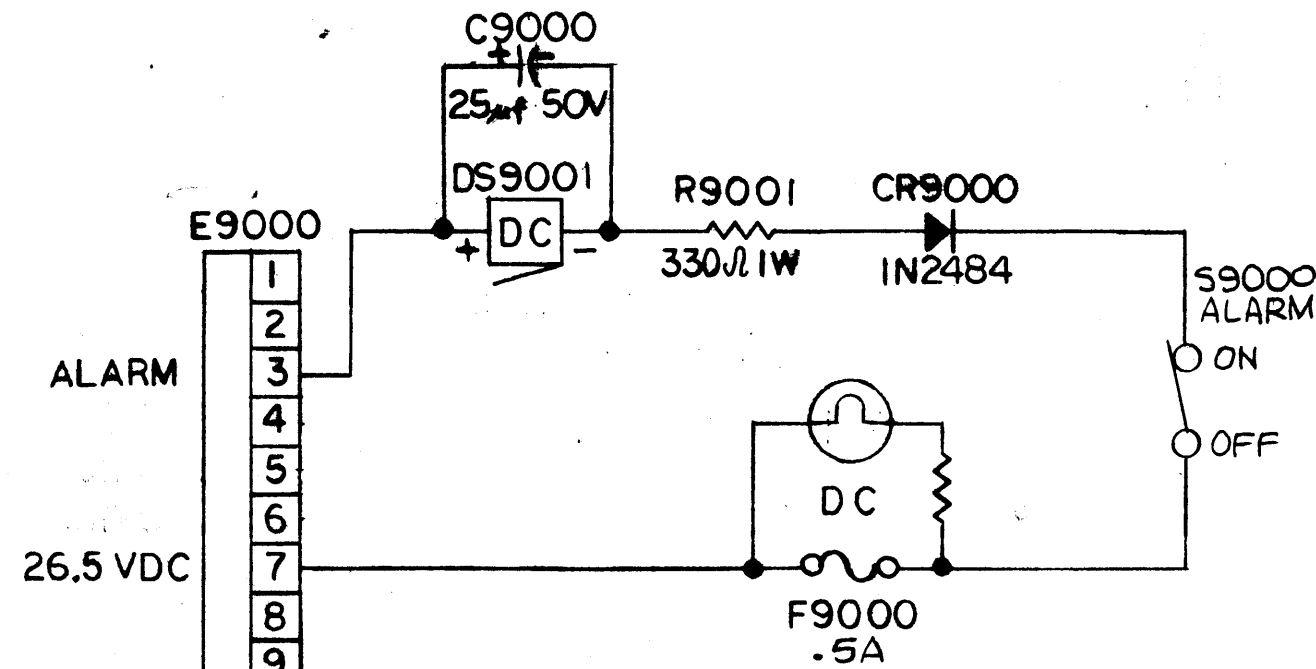

POS.	S9001 SENSE FUNCTION
1	100 MW TRIG
2	2ND AMPL TUNE
3	2ND AMPL PLATE TRIG
4	PA TUNE
5	PA PLATE TRIG
6	PA LOAD

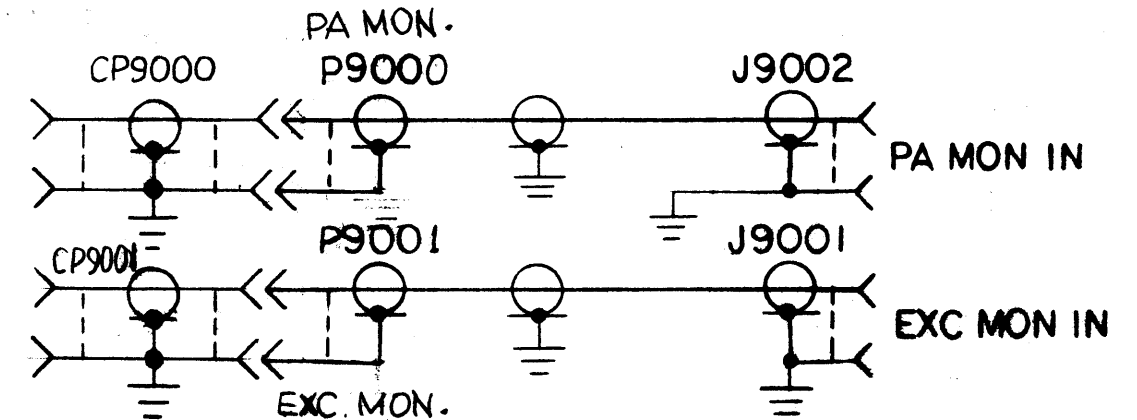
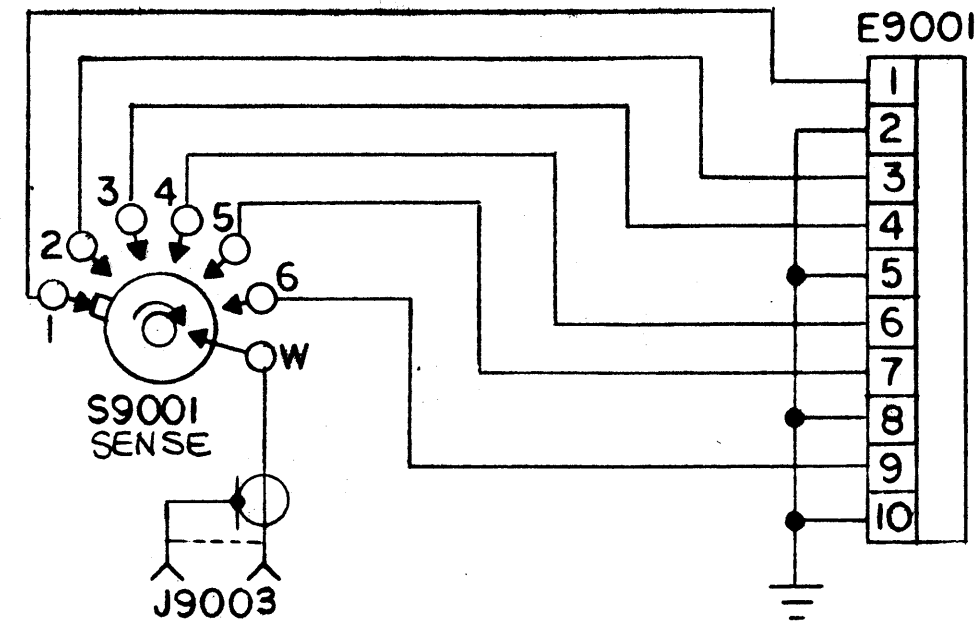

NOTES

QTY./UNIT	AX633	ASSY. NO.
SCALE	MODEL USED ON	CODE

THE CONTENTS OF THIS DRAWING ARE THE EXCLUSIVE PROPERTY OF THE TECHNICAL MATERIEL CORP. ITS UNAUTHORIZED USE OR REPRODUCTION IN WHOLE OR IN PART IS STRICTLY FORBIDDEN.

REQ'D.	ITEM	PART NUMBER	DESCRIPTION	SYMBOL
F BUDETTI LIST OF MATERIAL				
MATERIAL			THE TECHNICAL MATERIEL CORP. MAMARONECK, NEW YORK	
FINISH			TITLE	
			SCHEMATIC, MONITOR PANEL	
UNLESS OTHERWISE SPECIFIED DIMENSIONS ARE IN INCHES AND INCLUDE CHEMICALLY APPLIED OR PLATED FINISHES		DRAWN JBC	DATE 9-2-66	FINAL APPROVAL
DECIMALS X ± .05 XX ± .01 XXX ± .005		CHECKED	DATE	CK1207
FRACTIONS ± 1/64 ANGLES ± 0° 30'		ELECT. DES. [Signature]	DATE	
TOLERANCES		MECH. DES. [Signature]	DATE	A
				SHEET
				REV. CTS.