

IF IT IS FOUND DESIRABLE TO CHANGE ANY TOLERANCE OR OTHER DETAIL SPECIFIED ON THIS DRAWING NOTIFY THE PURCHASER PROMPTLY.

MAXIMUM ALLOWABLE TOLERANCES HAVE BEEN DETERMINED AND DEVIATIONS WILL BE CAUSE FOR REJECTION. REMOVE ALL BURRS AND SHARP EDGES

C-K-298

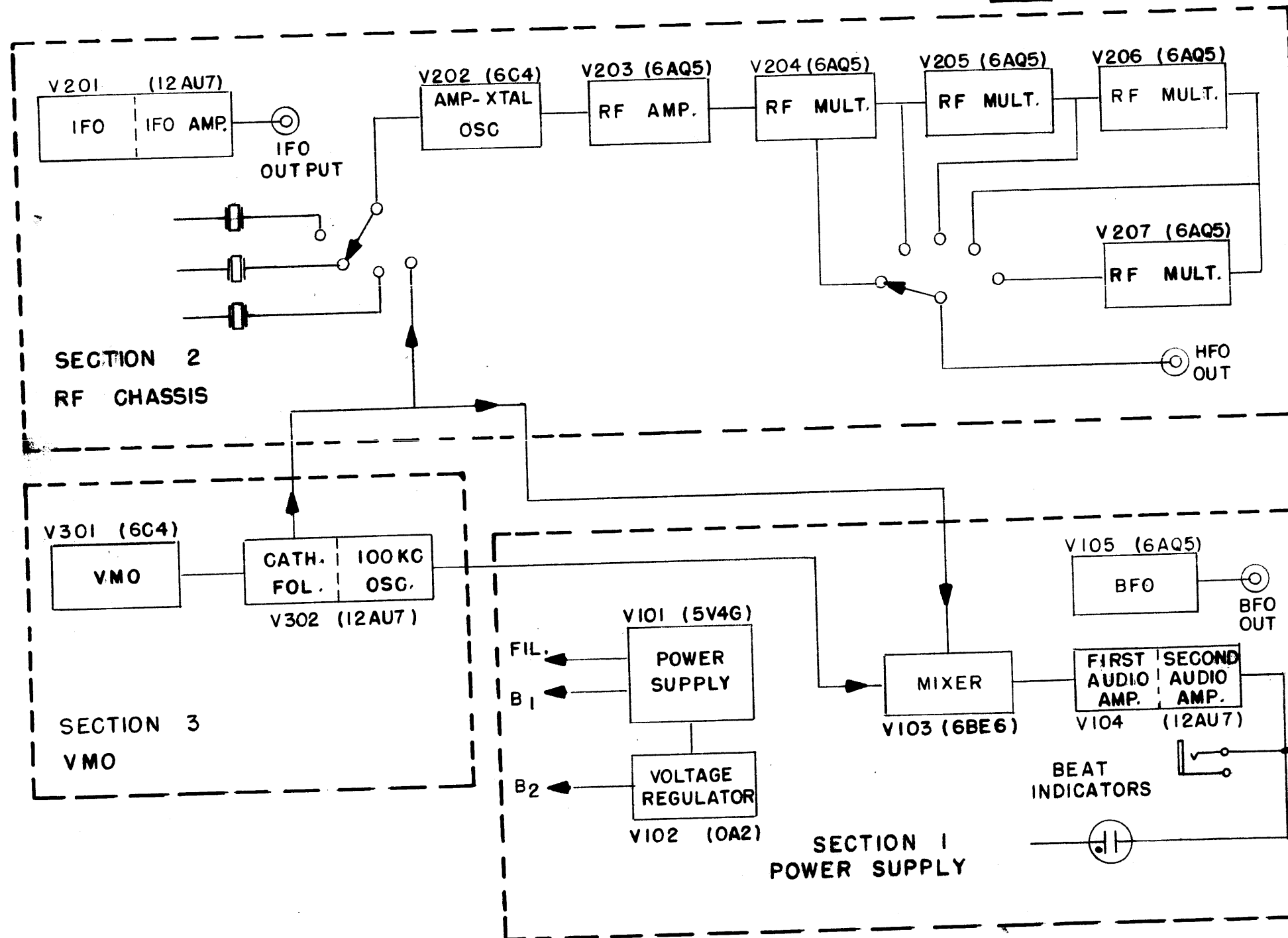

**NOTICE TO PERSONS RECEIVING THIS DRAWING**

THE TECHNICAL MATERIEL CORPORATION claims proprietary right in the material disclosed hereon. This drawing is issued in confidence for engineering information only and may not be reproduced or used to manufacture anything shown hereon without permission from THE TECHNICAL MATERIEL CORPORATION to the user. This drawing is loaned for mutual assistance and is subject to recall at any time.

Property of:  
THE TECHNICAL MATERIEL CORPORATION  
MAMARONECK, NEW YORK

| REQ.               | ITEM | PART NO. | DESCRIPTION  | SYMBOL                    |
|--------------------|------|----------|--|---------------------------|
|                    |      |          | THE TECHNICAL MATERIEL CORP.<br>MAMARONECK, NEW YORK |                           |
| STOCK SIZE         |      |          | FUNCTIONAL   |                           |
| MATERIAL           |      |          | BLOCK DIAGRAM  |                           |
| WEIGHT PER PC.     |      |          |  |                           |
| TYPE & TEMPER      |      |          | W.D. BOB<br>DRAWN                                    | A.J.J.<br>ELEC. DES. APP. |
| HEAT TREAT. SPEC.  |      |          | CHECKED  | FINAL APPROVAL            |
| FINISH & SPEC. NO. |      |          |  | CK-298                    |

| ISSUE   | ITEM | CHANGED FROM | DATE | CN. NO. | DRAFTS | CHECKER | ENG. APP. |
|---|------|--------------|------|---------|--------|---------|-----------|
| TOLERANCES  |      |              |      |         |        |         |           |
| SCALE:  |      |              |      |         |        |         |           |
| DRILL, PUNCH, COMMERCIAL STOCK SIZES AND MANUFACTURERS TOLERANCES ARE NOT INCLUDED. |      |              |      |         |        |         |           |
| ALL OTHERS  |      |              |      |         |        |         |           |
| DEC. DIM. ±   |      |              |      |         |        |         |           |
| FRAC. DIM. ±  |      |              |      |         |        |         |           |
| ANGULAR DIM. ±  |      |              |      |         |        |         |           |

|           |             |            |         |
|-----------|-------------|------------|---------|
| VOX-1-2   | PROJECT NO. | ASS'Y. NO. | DATE    |
| MODEL     |             |            | 4-22-55 |
| U E D O N |             |            |         |