

THE CONTENTS OF THIS DRAWING ARE THE EXCLUSIVE PROPERTY OF THE TECHNICAL MATERIEL CORP. ITS UNAUTHORIZED USE OR REPRODUCTION IN WHOLE OR IN PART IS STRICTLY FORBIDDEN.

REQ. PER UNIT
3

MODEL
HFR-1/T

USED ON
ASSY. NO. A-2485

DATE
6-8-62

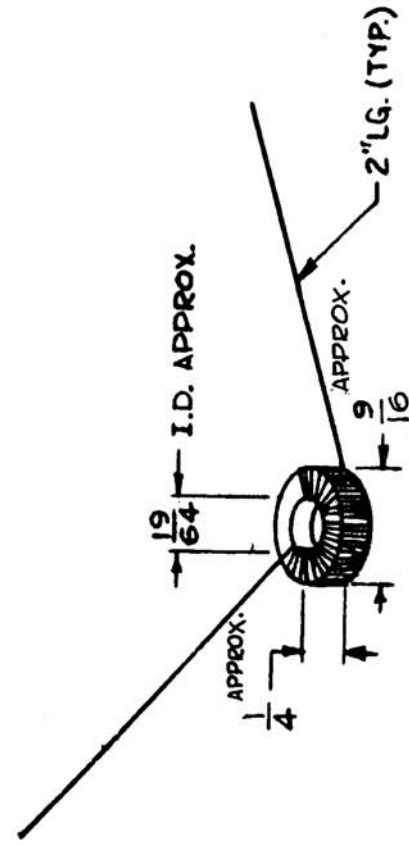

SCHEMATIC



| MODEL | REQ | FUNCTION | FREQ (MC) | SYMBOL |
|---------|-----|------------------------------|-----------|-------------|
| HFR-1/T | 3 | BAND - 1 RF STAGE - 2-3-4 | 2 - 3 MC | L1004, 6, 8 |

— ELECTRICAL SPECIFICATIONS —
 L - 21.2 μ h \pm 0.5 μ h
 UNIVERSAL WINDING
 CORE - POWDERED IRON

| REQ. ITEM | PART NO. | ANG. E. V. | DESCRIPTION | SYMBOL |
|-----------|----------|------------|---|--------|
| | | | THE TECHNICAL MATERIEL CORP. MAMARONECK, NEW YORK | |
| | | | COIL, RF, TOROID | |
| | | | RUEZZO | |
| | | | DRAWN | |
| | | | TYPE & TEMPER | |
| | | | HEAT TREAT. SPEC. | |
| | | | FINISH & SPEC. NO. | |
| | | | MATERIAL | |
| | | | STOCK SIZE | |
| | | | CHECKED | |
| | | | DATE | |
| | | | CM. NO. | |
| | | | DRAFTS | |
| | | | CHECKER | |
| | | | ENG. APP. | |
| | | | SCALE: A-2485 | |
| | | | UNLESS OTHERWISE SPECIFIED: DIMENSIONS ARE IN INCHES TOLERANCES ON FRAC. \pm 1/4 I.E.C. \pm .008 ANGLES \pm 1/2° | |
| | | | MAXIMUM ALLOWABLE TOLERANCES HAVE BEEN DETERMINED AND ANY DEVIATIONS WILL BE CAUSE FOR REJECTION. REMOVE ALL BURRS AND SHARP EDGES | |
| | | | MECH. DES. APP. | |
| | | | ELEC. DES. APP. | |
| | | | MECH. DES. APP. | |
| | | | FINISH & SPEC. NO. | |
| | | | TYPE & TEMPER | |
| | | | HEAT TREAT. SPEC. | |
| | | | DRAWN | |
| | | | CHECKED | |
| | | | DATE | |
| | | | FINISH & SPEC. NO. | |
| | | | MECH. DES. APP. | |
| | | | ELEC. DES. APP. | |
| | | | MECH. DES. APP. | |
| | | | FINISH & SPEC. NO. | |
| | | | TYPE & TEMPER | |
| | | | HEAT TREAT. SPEC. | |
| | | | DRAWN | |
| | | | CHECKED | |
| | | | DATE | |
| | | | FINISH & SPEC. NO. | |
| | | | MECH. DES. APP. | |
| | | | ELEC. DES. APP. | |
| | | | MECH. DES. APP. | |
| | | | FINISH & SPEC. NO. | |
| | | | TYPE & TEMPER | |
| | | | HEAT TREAT. SPEC. | |
| | | | DRAWN | |
| | | | CHECKED | |
| | | | DATE | |
| | | | FINISH & SPEC. NO. | |
| | | | MECH. DES. APP. | |
| | | | ELEC. DES. APP. | |
| | | | MECH. DES. APP. | |
| | | | FINISH & SPEC. NO. | |
| | | | TYPE & TEMPER | |
| | | | HEAT TREAT. SPEC. | |
| | | | DRAWN | |
| | | | CHECKED | |
| | | | DATE | |
| | | | FINISH & SPEC. NO. | |
| | | | MECH. DES. APP. | |
| | | | ELEC. DES. APP. | |
| | | | MECH. DES. APP. | |
| | | | FINISH & SPEC. NO. | |
| | | | TYPE & TEMPER | |
| | | | HEAT TREAT. SPEC. | |
| | | | DRAWN | |
| | | | CHECKED | |
| | | | DATE | |
| | | | FINISH & SPEC. NO. | |
| | | | MECH. DES. APP. | |
| | | | ELEC. DES. APP. | |
| | | | MECH. DES. APP. | |
| | | | FINISH & SPEC. NO. | |
| | | | TYPE & TEMPER | |
| | | | HEAT TREAT. SPEC. | |
| | | | DRAWN | |
| | | | CHECKED | |
| | | | DATE | |
| | | | FINISH & SPEC. NO. | |
| | | | MECH. DES. APP. | |
| | | | ELEC. DES. APP. | |
| | | | MECH. DES. APP. | |
| | | | FINISH & SPEC. NO. | |
| | | | TYPE & TEMPER | |
| | | | HEAT TREAT. SPEC. | |
| | | | DRAWN | |
| | | | CHECKED | |
| | | | DATE | |
| | | | FINISH & SPEC. NO. | |
| | | | MECH. DES. APP. | |
| | | | ELEC. DES. APP. | |
| | | | MECH. DES. APP. | |
| | | | FINISH & SPEC. NO. | |
| | | | TYPE & TEMPER | |
| | | | HEAT TREAT. SPEC. | |
| | | | DRAWN | |
| | | | CHECKED | |
| | | | DATE | |
| | | | FINISH & SPEC. NO. | |
| | | | MECH. DES. APP. | |
| | | | ELEC. DES. APP. | |
| | | | MECH. DES. APP. | |
| | | | FINISH & SPEC. NO. | |
| | | | TYPE & TEMPER | |
| | | | HEAT TREAT. SPEC. | |
| | | | DRAWN | |
| | | | CHECKED | |
| | | | DATE | |
| | | | FINISH & SPEC. NO. | |
| | | | MECH. DES. APP. | |
| | | | ELEC. DES. APP. | |
| | | | MECH. DES. APP. | |
| | | | FINISH & SPEC. NO. | |
| | | | TYPE & TEMPER | |
| | | | HEAT TREAT. SPEC. | |
| | | | DRAWN | |
| | | | CHECKED | |
| | | | DATE | |
| | | | FINISH & SPEC. NO. | |
| | | | MECH. DES. APP. | |
| | | | ELEC. DES. APP. | |
| | | | MECH. DES. APP. | |
| | | | FINISH & SPEC. NO. | |
| | | | TYPE & TEMPER | |
| | | | HEAT TREAT. SPEC. | |
| | | | DRAWN | |
| | | | CHECKED | |
| | | | DATE | |
| | | | FINISH & SPEC. NO. | |
| | | | MECH. DES. APP. | |
| | | | ELEC. DES. APP. | |
| | | | MECH. DES. APP. | |
| | | | FINISH & SPEC. NO. | |
| | | | TYPE & TEMPER | |
| | | | HEAT TREAT. SPEC. | |
| | | | DRAWN | |
| | | | CHECKED | |
| | | | DATE | |
| | | | FINISH & SPEC. NO. | |
| | | | MECH. DES. APP. | |
| | | | ELEC. DES. APP. | |
| | | | MECH. DES. APP. | |
| | | | FINISH & SPEC. NO. | |
| | | | TYPE & TEMPER | |
| | | | HEAT TREAT. SPEC. | |
| | | | DRAWN | |
| | | | CHECKED | |
| | | | DATE | |
| | | | FINISH & SPEC. NO. | |
| | | | MECH. DES. APP. | |
| | | | ELEC. DES. APP. | |
| | | | MECH. DES. APP. | |
| | | | FINISH & SPEC. NO. | |
| | | | TYPE & TEMPER | |
| | | | HEAT TREAT. SPEC. | |
| | | | DRAWN | |
| | | | CHECKED | |
| | | | DATE | |
| | | | FINISH & SPEC. NO. | |
| | | | MECH. DES. APP. | |
| | | | ELEC. DES. APP. | |
| | | | MECH. DES. APP. | |
| | | | FINISH & SPEC. NO. | |
| | | | TYPE & TEMPER | |
| | | | HEAT TREAT. SPEC. | |
| | | | DRAWN | |
| | | | CHECKED | |
| | | | DATE | |
| | | | FINISH & SPEC. NO. | |
| | | | MECH. DES. APP. | |
| | | | ELEC. DES. APP. | |
| | | | MECH. DES. APP. | |
| | | | FINISH & SPEC. NO. | |
| | | | TYPE & TEMPER | |
| | | | HEAT TREAT. SPEC. | |
| | | | DRAWN | |
| | | | CHECKED | |
| | | | DATE | |
| | | | FINISH & SPEC. NO. | |
| | | | MECH. DES. APP. | |
| | | | ELEC. DES. APP. | |
| | | | MECH. DES. APP. | |
| | | | FINISH & SPEC. NO. | |
| | | | TYPE & TEMPER | |
| | | | HEAT TREAT. SPEC. | |
| | | | DRAWN | |
| | | | CHECKED | |
| | | | DATE | |
| | | | FINISH & SPEC. NO. | |
| | | | MECH. DES. APP. | |
| | | | ELEC. DES. APP. | |
| | | | MECH. DES. APP. | |
| | | | FINISH & SPEC. NO. | |
| | | | TYPE & TEMPER | |
| | | | HEAT TREAT. SPEC. | |
| | | | DRAWN | |
| | | | CHECKED | |
| | | | DATE | |
| | | | FINISH & SPEC. NO. | |
| | | | MECH. DES. APP. | |
| | | | ELEC. DES. APP. | |
| | | | MECH. DES. APP. | |
| | | | FINISH & SPEC. NO. | |
| | | | TYPE & TEMPER | |
| | | | HEAT TREAT. SPEC. | |
| | | | DRAWN | |
| | | | CHECKED | |
| | | | DATE | |
| | | | FINISH & SPEC. NO. | |
| | | | MECH. DES. APP. | |
| | | | ELEC. DES. APP. | |
| | | | MECH. DES. APP. | |
| | | | FINISH & SPEC. NO. | |
| | | | TYPE & TEMPER | |
| | | | HEAT TREAT. SPEC. | |
| | | | DRAWN | |
| | | | CHECKED | |
| | | | DATE | |
| | | | FINISH & SPEC. NO. | |
| | | | MECH. DES. APP. | |
| | | | ELEC. DES. APP. | |
| | | | MECH. DES. APP. | |
| | | | FINISH & SPEC. NO. | |
| | | | TYPE & TEMPER | |
| | | | HEAT TREAT. SPEC. | |
| | | | DRAWN | |
| | | | CHECKED | |
| | | | DATE | |
| | | | FINISH & SPEC. NO. | |
| | | | MECH. DES. APP. | |
| | | | ELEC. DES. APP. | |
| | | | MECH. DES. APP. | |
| | | | FINISH & SPEC. NO. | |
| | | | TYPE & TEMPER | |
| | | | HEAT TREAT. SPEC. | |
| | | | DRAWN | |
| | | | CHECKED | |
| | | | DATE | |
| | | | FINISH & SPEC. NO. | |
| | | | MECH. DES. APP. | |
| | | | ELEC. DES. APP. | |
| | | | MECH. DES. APP. | |
| | | | FINISH & SPEC. NO. | |
| | | | TYPE & TEMPER | |
| | | | HEAT TREAT. SPEC. | |
| | | | DRAWN | |
| | | | CHECKED | |
| | | | DATE | |
| | | | FINISH & SPEC. NO. | |
| | | | MECH. DES. APP. | |
| | | | ELEC. DES. APP. | |
| | | | MECH. DES. APP. | |
| | | | FINISH & SPEC. NO. | |
| | | | TYPE & TEMPER | |
| | | | HEAT TREAT. SPEC. | |
| | | | DRAWN | |
| | | | CHECKED | |
| | | | DATE | |
| | | | FINISH & SPEC. NO. | |
| | | | MECH. DES. APP. | |
| | | | ELEC. DES. APP. | |
| | | | MECH. DES. APP. | |
| | | | FINISH & SPEC. NO. | |
| | | | TYPE & TEMPER | |
| | | | HEAT TREAT. SPEC. | |
| | | | DRAWN | |
| | | | CHECKED | |
| | | | DATE | |
| | | | FINISH & SPEC. NO. | |
| | | | MECH. DES. APP. | |
| | | | ELEC. DES. APP. | |
| | | | MECH. DES. APP. | |
| | | | FINISH & SPEC. NO. | |
| | | | TYPE & TEMPER | |
| | | | HEAT TREAT. SPEC. | |
| | | | DRAWN | |
| | | | CHECKED | |
| | | | DATE | |
| | | | FINISH & SPEC. NO. | |
| | | | MECH. DES. APP. | |
| | | | ELEC. DES. APP. | |
| | | | MECH. DES. APP. | |
| | | | FINISH & SPEC. NO. | |
| | | | TYPE & TEMPER | |
| | | | HEAT TREAT. SPEC. | |
| | | | DRAWN | |
| | | | CHECKED | |
| | | | DATE | |
| | | | FINISH & SPEC. NO. | |
| | | | MECH. DES. APP. | |
| | | | ELEC. DES. APP. | |
| | | | MECH. DES. APP. | |
| | | | FINISH & SPEC. NO. | |
| | | | TYPE & TEMPER | |
| | | | HEAT TREAT. SPEC. | |
| | | | DRAWN | |
| | | | CHECKED | |
| | | | DATE | |
| | | | FINISH & SPEC. NO. | |
| | | | MECH. DES. APP.</ | |