

THE CONTENTS OF THIS DRAWING ARE THE EXCLUSIVE PROPERTY OF THE TECHNICAL MATERIEL CORP. ITS UNAUTHORIZED USE FOR REPRODUCTION IN WHOLE OR IN PART IS STRICTLY FORBIDDEN.

REQ. PER UNIT
1

USED ON
ASS'Y. NO.

DATE
3-26-63

CL-308

A

MODEL
TER-5000-300U

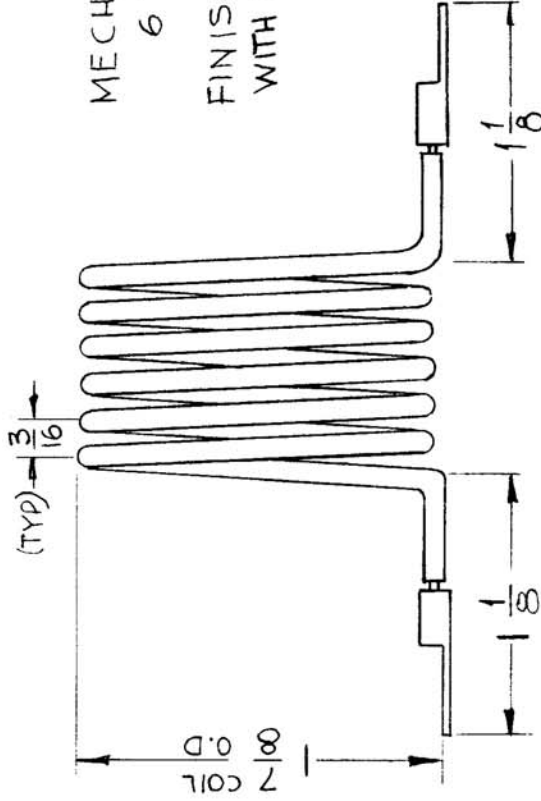
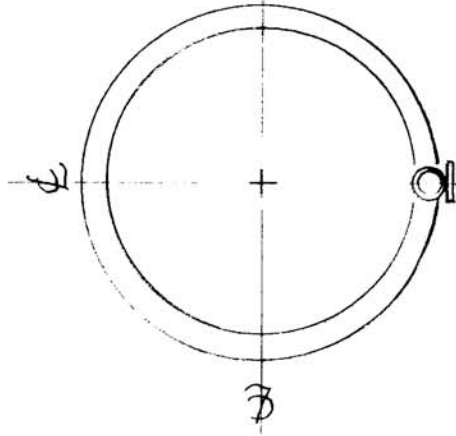

MECHANICAL SPECIFICATIONS
6 TURNS WOUND ON 1/2" D. FORM
FINISH: SILVER PLATE .0003 THK.
WITH TEFLON SLEEVING.

SYMBOL

DESCRIPTION

SCALE

DATE

CH. NO.

9827

AK

9/26/63

1A-3132

DESCRIPTION

UNLESS OTHERWISE SPECIFIED DIMENSIONS ARE IN INCHES AND INCLUDE CHEMICALLY APPLIED OR PLATED FINISHES

TOLERANCES

FRACTIONS

DECIMALS

± .05

± .01

± .005

± 1/64

ANGLES

± 0° 30'

REQ. ITEM

PART NO.

STOCK SIZE

MATERIAL

TYPE & TEMPER

HEAT TREAT. SPEC.

FINISH & SPEC. NO.

BUDETTI

DESCRIPTION

THE TECHNICAL MATERIEL CORP.
MAMARONECK. NEW YORK

COIL, COMPENSATING

G.D.L.

DRAWN

APPROVED

CL-308

A

MECH. DES. APP.

ELEC. DES. APP.

OGILVIE PLESS, INC., BROOKLYN 17, N. Y.

REPROVAL NO. 400H

3787