

REV. PER. UNIT	USED ON
1	CHG-1 GEAR ASSY
MODEL	DATE
CHG-1	2-12-61

GR-164

PITCH DIA. 1.1458"
 PITCH 48
 NO. OF TEETH 55
 PRESSURE ANGLE 14 1/2°
 COMM. CLASS 3TOL.
 TYPE ANTI-BACKLASH

DR. & TAP 6-32 CLASS 2
 2 REQ.
 NOTE RELATION OF TAPPED
 HOLES TO CUTOUT.

NOTE:
 LUBRICATE LIGHTLY
 BETWEEN GEARS.

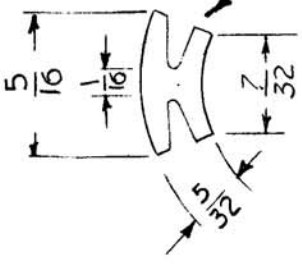

CUTOUT DETAIL (2REQ.)
 DIM. FOR REF. ONLY

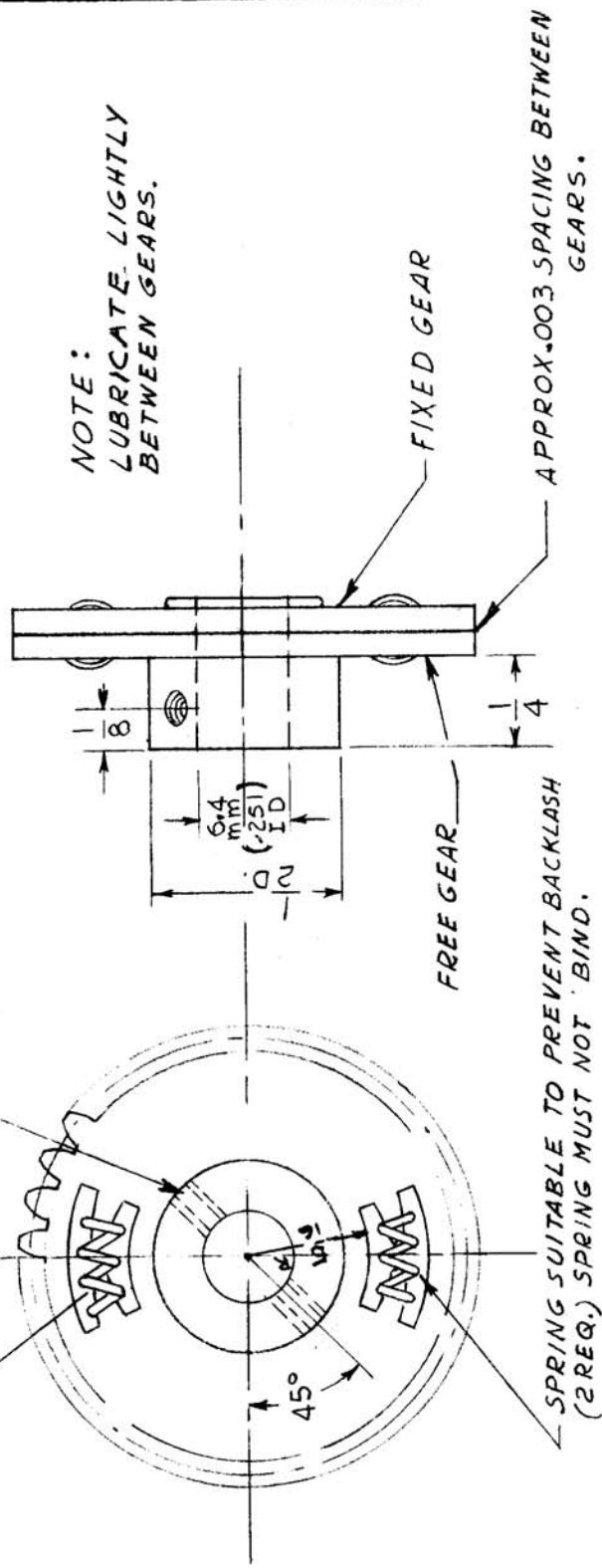

SPRING SUITABLE TO PREVENT BACKLASH
 (2REQ.) SPRING MUST NOT BIND.

REF: N.J. GEAR WORKS

REQ. ITEM	PART NO.	DESCRIPTION	SYMBOL
.0625 thk (each gear)		THE TECHNICAL MATERIEL CORP.	
STOCK SIZE		MAMARONECK, NEW YORK	
ALUMINUM		GEAR, SPLIT, 1.1458 P.D.	
MATERIAL			
2024-T3			
TYPE & TEMPER	HEATTREAT. SPEC.	CHECKED	FINAL APPROVAL
YELLOW ANODIZE		<i>[Signature]</i>	<i>[Signature]</i>
FINISH & SPEC. NO.		DRAWN	GR-164
		ELEC. DES. APP	

TOLERANCES

MAXIMUM ALLOWABLE TOLERANCES HAVE BEEN DETERMINED AND ANY DEVIATIONS WILL BE CAUSE FOR REJECTION. REMOVE ALL BURRS AND SHARP EDGES