

IF IT IS FOUND DESIRABLE TO CHANGE ANY TOLERANCE OR OTHER DETAIL SPECIFIED ON THIS DRAWING NOTIFY THE PURCHASER PROMPTLY.
 MAXIMUM ALLOWABLE TOLERANCES HAVE BEEN DETERMINED AND DEVIATIONS WILL BE CAUSE FOR REJECTION. REMOVE ALL BURRS AND SHARP EDGES

PROPERTY RIGHTS RECEIVING THIS DRAWING
 THE TECHNICAL MATERIEL CORPORATION claims proprietary right in the material disclosed hereon. This drawing is issued in confidence for engineering information only and may not be reproduced or used to manufacture anything shown herein without permission from THE TECHNICAL MATERIEL CORPORATION to the user. This drawing is loaned for mutual assistance and is subject to recall at any time.
 Property of:
 THE TECHNICAL MATERIEL CORPORATION
 MAMARONECK, NEW YORK

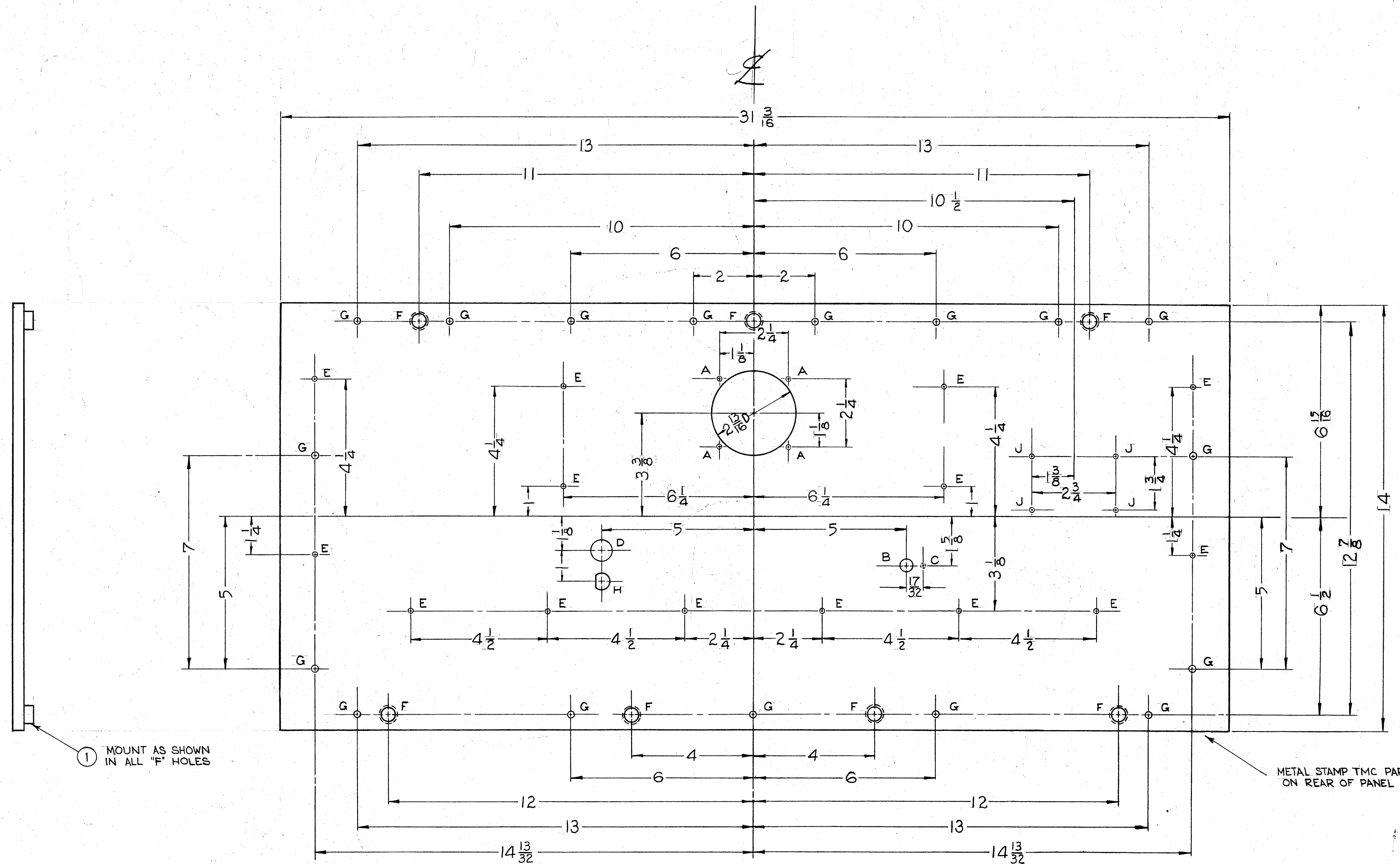

FRONT VIEW OF PANEL

HOLE LEGEND
 A ~ 5/32 (.156) DIA.
 B ~ 25/64 (.390) "
 C ~ 9/64 DIA. X 1/8 DEEP FROM REAR
 D ~ 45/64 (.703) DIA.
 E ~ # 18 DRILL (.169) DIA.
 F ~ SEE "F" DETAIL
 G ~ 15/64 (.234) DIA.
 J ~ # 47 DRILL

4 HOLES REQ.
14
7
17
4

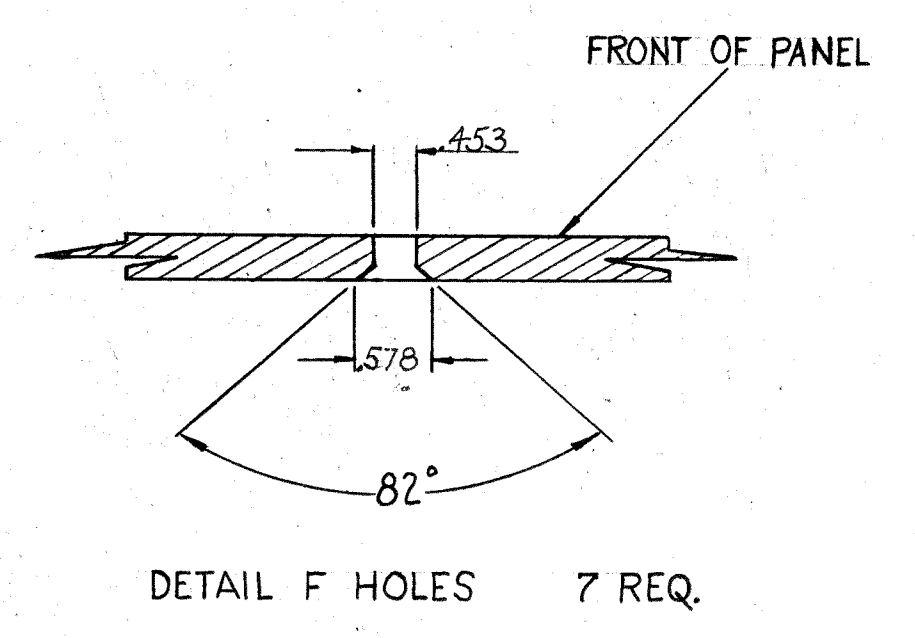
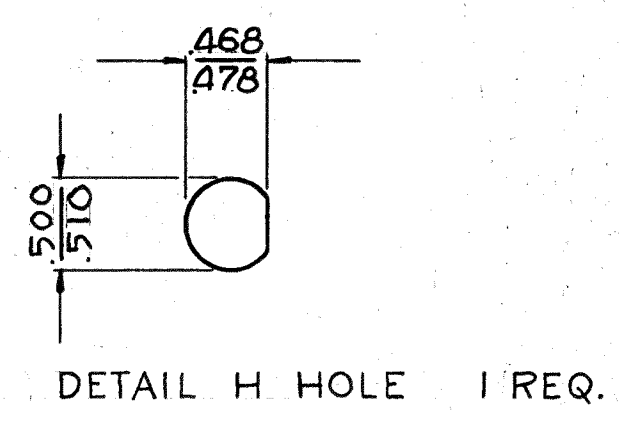

METAL STAMP TMC PART No. 1/8 HIGH GOTHIC ON REAR OF PANEL (MS-1361-C)

NOTES

- FINISH -**
 S404 YELLOW IRIDITE
 S114 ZINC CHROMATE PRIMER FRONT & EDGES
 S115 TMC SMOOTH GREY ENAMEL OR PRIME & PAINT TO CUST SPEC. ONLY
- MACHINING -**
 1. LATERAL BOW OF PANEL MUST BE KEPT TO .031 TOLERANCE.
 2. MILL ALL EDGES.
 3. HOLES MUST BE DRILLED.
 4. PANEL MUST BE FREE OF ALL MACHINING MARKS, GOUGES, AND SCRATCHES. IF NECESSARY, SAND FRONT OF PANEL WITH NO. 120 GRIT SANDPAPER.

REF: LD-452, PM-504, PM-505

REQ. ITEM	PART NO.	DESCRIPTION	SYMBOL
7	NT-124	CAPTIVE INSERT	F
3/16		THE TECHNICAL MATERIEL CORP. MAMARONECK, NEW YORK	
ALUMINUM		FRONT PANEL	
2024-T3		J.G. BIELE DRAWN	
HEAT TREAT. SPEC.		CHECKED	
SEE NOTE		APPROVAL	
FINISH & SPEC. NO.		MS-1361 C	

ISSUE	ITEM	CHANGED FROM	DATE	DN. NO.	DRAFTS	CHECKER	ENG. APP.
C	1	ITEM (1) SIDE VIEW ADDED	4-22-63	8829			
B	3	S-404 WAS S-101	2/16/64	1001			
B	2	453 WAS 15/32	2/16/64	165D			
A	1	578 WAS 17/32	1/16/64	574			

TOLERANCES:
 ALL DEC. DIM. ± 1/64
 DRILL PUNCH, COMMERCIAL STOCK SIZES AND MANUFACTURERS TOLERANCES ARE NOT INCLUDED.

REQ. PER UNIT	MODEL	PROJECT NO.	ASBY. NO.	DATE
1	RTM-2			10-8-58

MS-1361 C