

IF IT IS FOUND DESIRABLE TO CHANGE ANY TOLERANCE OR OTHER DETAIL SPECIFIED ON THIS DRAWING NOTIFY THE PURCHASER PROMPTLY.

NP10065

MAXIMUM ALLOWABLE TOLERANCES HAVE BEEN DETERMINED AND DEVIATIONS WILL BE CAUSE FOR REJECTION. REMOVE ALL BURRS AND SHARP EDGES

USED ON

MODEL

PROJECT NO.

ASS'Y. NO.

DATE

TST-2

6/23/60

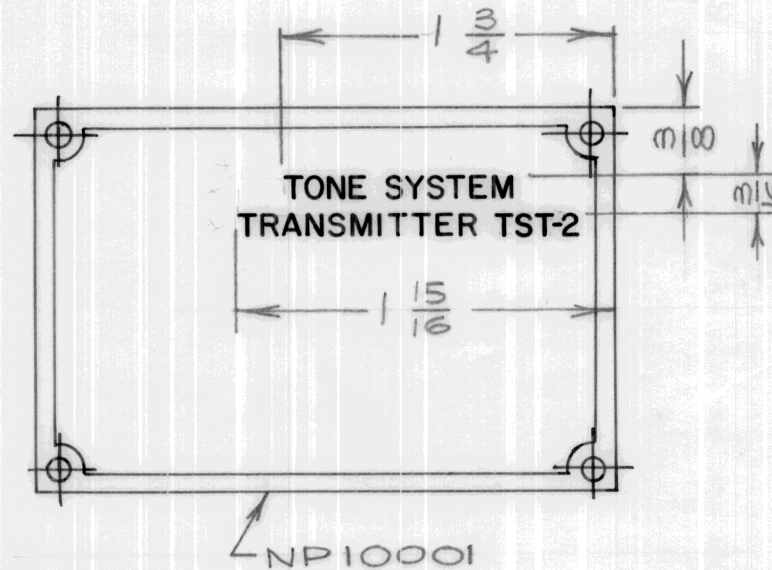

NOTICE TO PERSONS RECEIVING THIS DRAWING

THE TECHNICAL MATERIEL CORPORATION claims proprietary right in the material disclosed hereon. This drawing is issued in confidence for engineering information only and may not be reproduced or used to manufacture anything shown hereon without permission from THE TECHNICAL MATERIEL CORPORATION to the user. This drawing is loaned for mutual assistance and is subject to recall at any time.

Property of:

THE TECHNICAL MATERIEL CORPORATION
MAMARONECK, NEW YORK

REQ.	ITEM	PART NO.	DESCRIPTION	SYMBOL
			TMC (Canada) LIMITED OTTAWA ONTARIO	
		STOCK SIZE	NAMEPLATE	
		MATERIAL	TST-2	
		WEIGHT PER PC.		
		TYPE & TEMPER	JPC	
		HEAT TREAT. SPEC.	DRAWN	ELEC. DES. APP. MECH. DES. APP.
		FINISH & SPEC. NO.	CHECKED	FINAL APPROVAL
				NP10065

ISSUE	ITEM	CHANGED FROM	DATE	CN. NO.	DRAFTS	CHECKER	ENG. APP.
TOLERANCES			SCALE :				
ALL OTHERS	DEC. DIM. ±		DIMENSIONS IN INCHES UNLESS OTHERWISE SPECIFIED				
	FRAC. DIM. ± 1/64		DRILL. PUNCH. COMMERCIAL STOCK SIZES AND MANUFACTURERS TOLERANCES ARE NOT INCLUDED.				
	ANGULAR DIM. ±						