

HOLES

REQ.

A-1/8 DIA.
B-7/16 DIA.

4
1

NP-620 0

REVISIONS

SYM	DESCRIPTION	DATE	E.M.N. NO.	DRAFT	CHKD	APPD
0	ORIGINAL RELEASE FOR PRODUCTION	3-16-64				

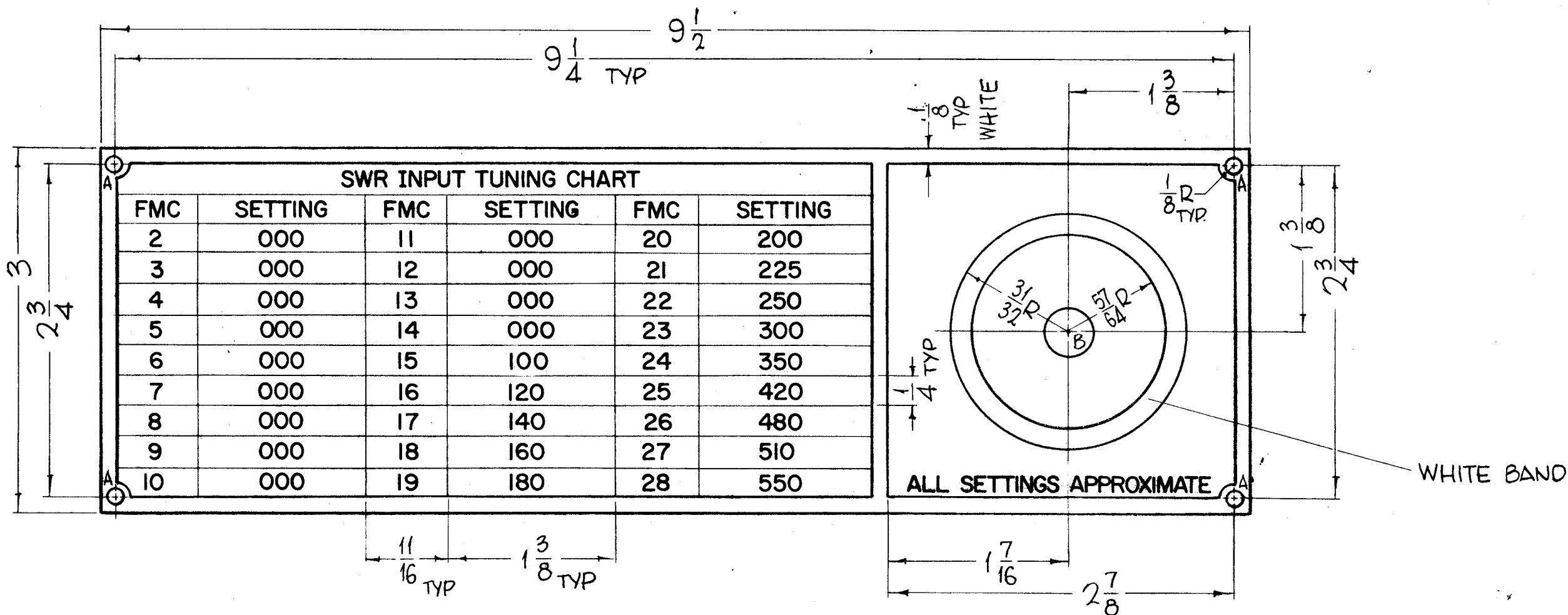

ALL LETTERING TO BE 1/8 HIGH WHITE GOTHIC, ON BLACK BACKGROUND
BORDERS, LINEWORK & BAND TO BE WHITE (SIZES AS SHOWN)

REQ'D.	ITEM	PART NUMBER	DESCRIPTION	SYMBOL
--------	------	-------------	-------------	--------

F. BUDETTI

LIST OF MATERIAL

MATERIAL 032 THICK,
ALUMINUM, TYPE 6 TEMP 250

THE TECHNICAL MATERIEL CORP.
MAMARONECK, NEW YORK

FINISH
SEE NOTES

TITLE
PLATE, DESIGNATION, SWR INPUT TUNING

1	GPT-200K	AX-392
Q'TY./UNIT	MODEL USED ON	ASS'Y. NO.
SCALE #	CODE A	

UNLESS OTHERWISE SPECIFIED
DIMENSIONS ARE IN INCHES AND INCLUDE
CHEMICALLY APPLIED OR PLATED FINISHES

DRAWN	DATE	FINAL APPROVAL	DATE
John C. Biele	12-24-63	RJ	4-7-64

DECIMALS	TOLERANCES	FRACTIONS
.X ± .05		± 1/64
.XX ± .01		ANGLES ± 0° 30'
.XXX ± .005		

CHECKED	DATE	DATE	DATE
JCB	3-16-64	3-16-64	
ELECT. DES.	MECH. DES. aa		
		NP-620	0
		SHEET	REV. LTR.

NOTES

THE CONTENTS OF THIS DRAWING ARE THE EXCLUSIVE PROPERTY
OF THE TECHNICAL MATERIEL CORP. ITS UNAUTHORIZED USE OR
REPRODUCTION IN WHOLE OR IN PART IS STRICTLY FORBIDDEN.