

IF IT IS FOUND DESIRABLE TO CHANGE ANY TOLERANCE OR OTHER DETAIL SPECIFIED ON THIS DRAWING NOTIFY THE PURCHASER PROMPTLY.

MAXIMUM ALLOWABLE TOLERANCES HAVE BEEN DETERMINED AND DEVIATIONS WILL BE CAUSE FOR REJECTION. REMOVE ALL BURRS AND SHARP EDGES

PX-189 A

A - 3/16 (.187) D. 4 HOLES REQ.
 B - 1/4 (.250) D. 1 " " "
 C - 25/64 (.390) D. 2 " " "

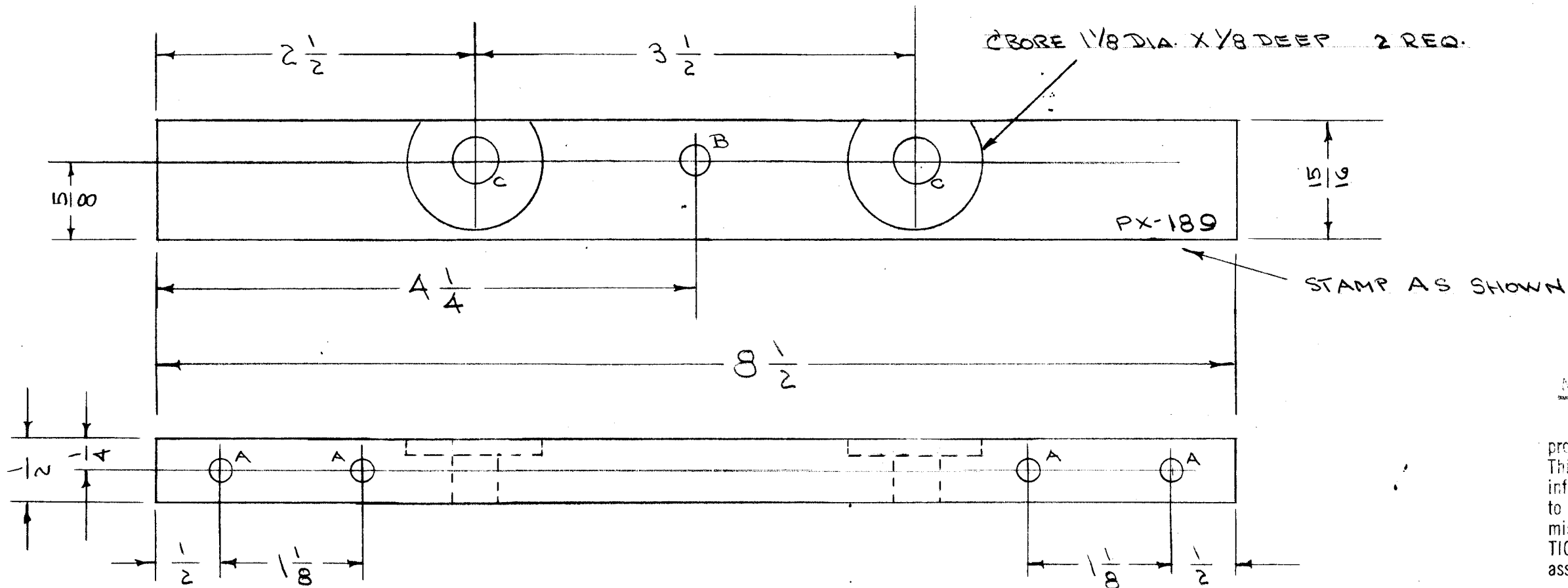

NOTICE TO PERSONS RECEIVING THIS DRAWING

THE TECHNICAL MATERIEL CORPORATION claims proprietary right in the material disclosed hereon. This drawing is issued in confidence for engineering information only and may not be reproduced or used to manufacture anything shown hereon without permission from THE TECHNICAL MATERIEL CORPORATION to the user. This drawing is loaned for mutual assistance and is subject to recall at any time.

Property of:

THE TECHNICAL MATERIEL CORPORATION
 MAMARONECK, NEW YORK

REQ.	ITEM	PART NO.	DESCRIPTION	SYMBOL
		1/2 THK.	THE TECHNICAL MATERIEL CORP.	
		STOCK SIZE	MAMARONECK. NEW YORK	
	PHENOLIC	#	FRONT COND. BRACKET	
	MATERIAL	WEIGHT PER PC.	TAC-1	
	XXX LAMINATE		C.D.D.	AKB
	TYPE & TEMPER		DRAWN	WSE
	#		ELEC. DES. APP.	WSE
	HEAT TREAT. SPEC.		CHECKED	FINAL APPROVAL
	NATURAL			PX-189
	FINISH & SPEC. NO.			A

ISSUE	ITEM	CHANGED FROM	DATE	CN. NO.	DRAFTS	CHECKER	ENG. APP.
A	1	25/64 WAS 3/8		1	C.D.D.		WSE

TOLERANCES: DEC. DIM. ±, FRAC. DIM. ± 1/64, ANGULAR DIM. ±

SCALE: #

DRILL, PUNCH, COMMERCIAL STOCK SIZES AND MANUFACTURERS TOLERANCES ARE NOT INCLUDED.

1	TAC-1	132	A-723	1-25-54
REQ. PER UNIT	MODEL	PROJECT NO.	ASS'Y. NO.	DATE

USED ON