

PX-674 0

REVISIONS

SYM	DESCRIPTION	DATE	E.M.N. NO.	DRAFT	CHKD	APPD
0	ORIGINAL RELEASE FOR PRODUCTION	3-264		A.M.		

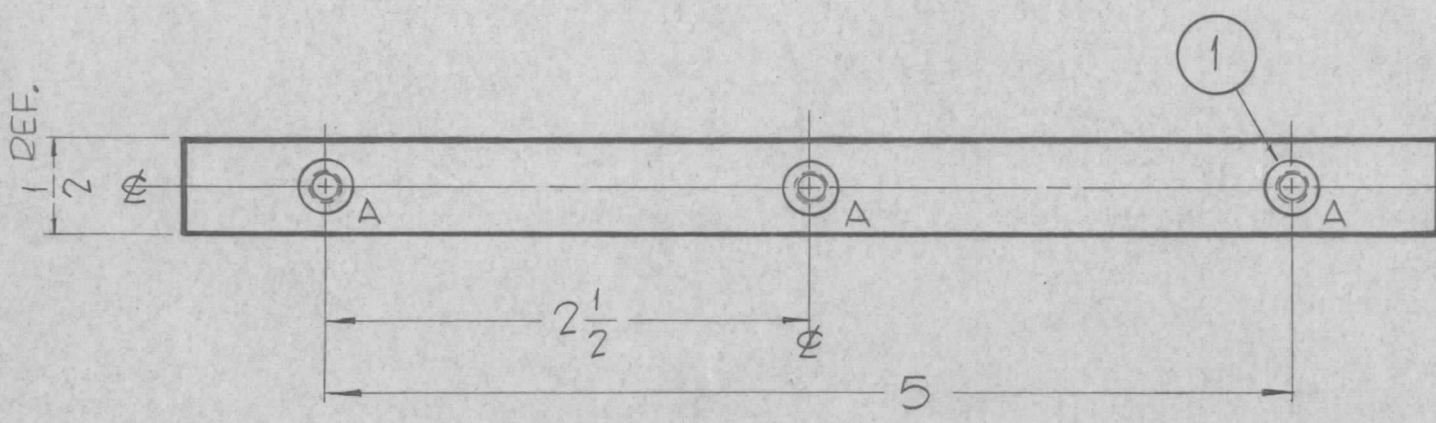
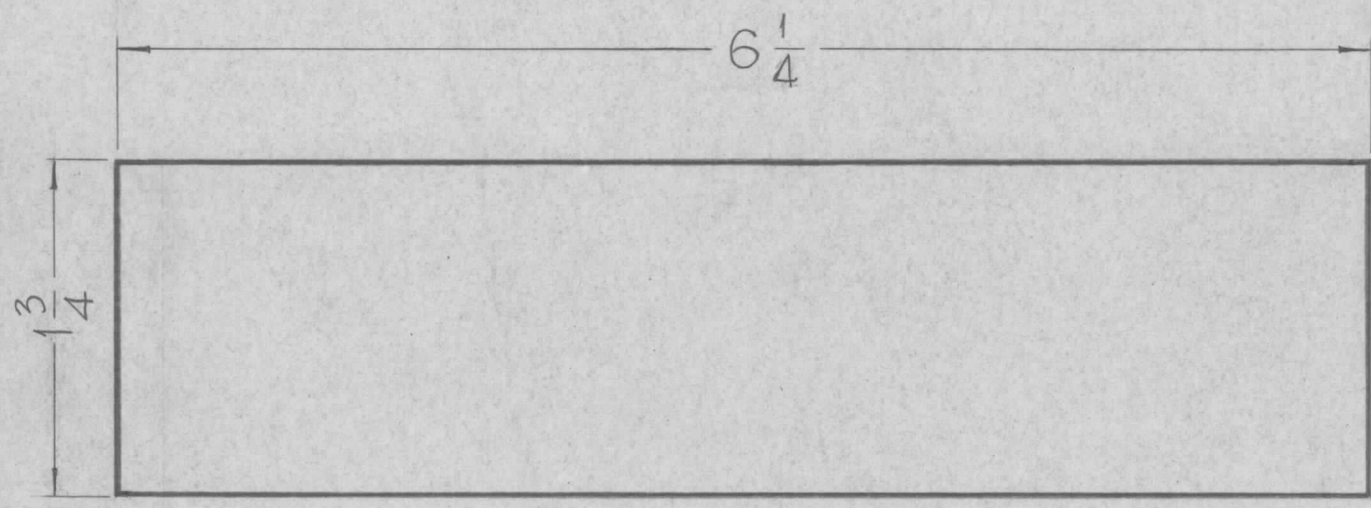
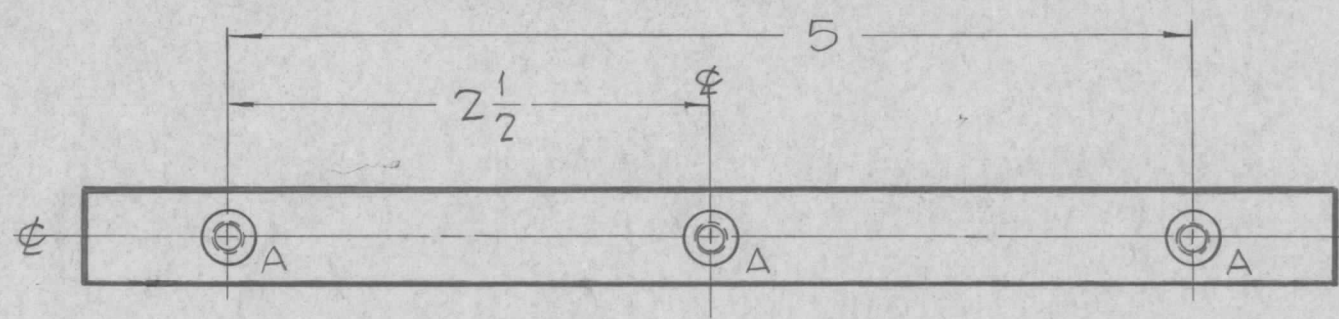

HOLE A-1~DRILL 13/64(.200) TO .552 MIN. DEPTH.
 (6 REQ) 2~120° COUNTERSINK .22-.25 DIA.
 A~DRILL 3~TAP .410 MIN. DEPTH. USE HELI-COIL TAP #3FPB 5 REQ
 4~INSTALL ITEM ① 3/4 TO 1-1/2 PITCH BELOW SURFACE
 5~BREAK OFF DRIVING TANG.

REQ'D.	ITEM	PART NUMBER	DESCRIPTION	SYMBOL
6	1	NT-139-SF1-20	INSERT, SCREW THREADED	A

F. BUDETTI LIST OF MATERIAL

MATERIAL	1/2 THICK, EPOXY, G-11	THE TECHNICAL MATERIEL CORP. MAMARONECK, NEW YORK
FINISH	NATURAL	TITLE BOARD, SPACER

1	GPT-200K	AX-398
Q'TY./UNIT	MODEL USED ON	ASS'Y. NO.
SCALE 1:1	CODE A	

NOTES

THE CONTENTS OF THIS DRAWING ARE THE EXCLUSIVE PROPERTY OF THE TECHNICAL MATERIEL CORP. ITS UNAUTHORIZED USE OR REPRODUCTION IN WHOLE OR IN PART IS STRICTLY FORBIDDEN.

UNLESS OTHERWISE SPECIFIED DIMENSIONS ARE IN INCHES AND INCLUDE CHEMICALLY APPLIED OR PLATED FINISHES	DRAWN	DATE	FINAL APPROVAL	DATE
	John C. Biele	7/25/62	KJC	
	CHECKED	DATE		
	JCB	2/10/64		
DECIMALS .X ± .05 .XX ± .01 .XXX ± .005	TOLERANCES	FRACTIONS	DATE	SHEET
		± 1/64 ANGLES ± 0° 30'		
			2/10/64	PX-674
				0
				REV. LTR.