

DATE 10-23-58

SH. 1 OF 10

COMPILED BY

PLK.

TMC SPECIFICATION NO. S - 395

TITLE: RSC-2 to RSC-3 MODIFICATION KIT

JOB REV/A

APPROVED *PLK. JDR* MODIFICATION KIT, TMC NO. 143

I. PURPOSE:

To describe the procedure for modifying the RSC-2 to become an RSC-3.

A. Changes Involved:

1. Changing the Front Panel arrangement to accommodate a new Main Tuning Dial Assembly, A-1590.
2. Replacing the existing loudspeaker, LS-102, with a new improved loudspeaker, LS-104.

II. PROCEDURE:

A. Main Tuning Dial Assembly:

1. Items Required (Supplied in Kit)

Item
No.

1. One each A-1590, Main Tuning Dial Assembly.
 2. Four each SCBS0348BC14, Screw, 3-48 Threads, 7/8" long.
 3. Two each SCBS0348BC4, Screw, 3-48 Threads, 1/4" long.
 4. Four each LWEO3MRC, Lockwasher, External, 3-48 Threads.
 5. Four each NTHO348BC6, Nut Hexagon, 3-48 Threads.
 6. Two each LD-456, Main Tuning Dial.
 7. One each LD-457, RF Gain Dial.
 8. One each LD-458, BFO Dial.
 9. One each MP-108-2, Knob, Skirted, Small.
 10. One each 7/64 Diameter Drill.
 11. One each CA-401-0-1-6.5, Cable, Insulated, #22, Black, 6-1/2" long, marked with #1.
 12. One each CA-401-5-2-5, Cable, Insulated, #22, Green, 5" long, marked with #2.
 13. One each CA-401-96-3-5.5, Cable, Insulated, #22, White/Blue, 5 1/2" long, marked with #3.
 14. One each CA-401-0-4-4.5, Cable, Insulated, #22, Black, 4 1/2" long, marked with #4.
 15. One each CA-401-5-5-6, Cable, Insulated, #22, Green, 6" long, marked with #5.
 16. One each CA-401-96-6-6.5, Cable, Insulated, #22, White/Blue, 6-1/2" long, marked with #6.
2. Remove Nameplate from Front Panel of RSC-2.
 3. Assemble Nameplate to Main Tuning Dial Panel with two 3-48 X 1/4" long screws (item 3), two lockwashers (item 4), and two nuts (item 5), using the two bottom holes as shown in Figure 1.
 4. R.F. Gain Control:
 - a. Remove small skirt knob (which will be used for new RF Gain Control)

DATE 10-23-58
SH. 2 OF 10
COMPILED BY

TMC SPECIFICATION NO. S - 395

TITLE: RSC-2 to RSC-3 MODIFICATION KIT

JOB REVA

APPROVED

MODIFICATION KIT, TMC NO. 143

- b. Remove shaft stop pin.
 - c. Loosen the knob shaft set screws on coupling.
 - d. Remove rear "C" - washer from shaft.
 - e. Pull shaft through bushing from front of panel.
 - f. Remove bushing nut and lockwasher on front of panel.
 - g. Remove bushing from rear of panel.
5. Drill out the top two nameplate holes on the Front Panel with a 7/64" drill (item 10).
6. Remove the Channel card holder from top of Front Panel. (Above R.F. Gain.)
7. Mounting of the Main Tuning Dial Assembly in Place of the R.F. Gain Control (See Figure 1)
- a. Place the Dial Assembly (item 1) on Front Panel as shown in Figure 1 and insert Dial Assembly shaft into the insulated coupling. (Do not tighten Set Screws).
 - b. Insert two 3-48 X 7/8" long screws (item 2) into the two top holes of the Dial Assembly and screw them into the two card holder tapped holes on the Front Panel.
 - c. Insert two 3-48 X 7/8" (item 2) into the two top holes in the Nameplate on the Dial Assembly and pass them through the new 7/64" diameter drilled holes in the Front Panel. Fasten on rear of Panel with two #3 Lockwashers (item 4), and two 3-48 nuts (item 5).
 - d. Turn the Tuning Knob on the Dial Assembly so that the pointer is in a horizontal position pointing to the left.
 - e. Turn the Tuning Condenser counter-clockwise to its closed position and tighten the coupling set screws.
 - f. Turn the Tuning Knob so the pointer is in a vertical position and insert the shaft stop pin, from the top, into the tuning shaft tapped hole, and tighten.
 - g. Insert the two Tuning Dials (item 6) into slot as shown in Figure 1.

DATE _____
SH. 3 OF 10
COMPILED BY _____

TMC SPECIFICATION NO. S

TITLE: _____

JOB REV. A

APPROVED _____

MODIFICATION KIT, TMC NO. 143

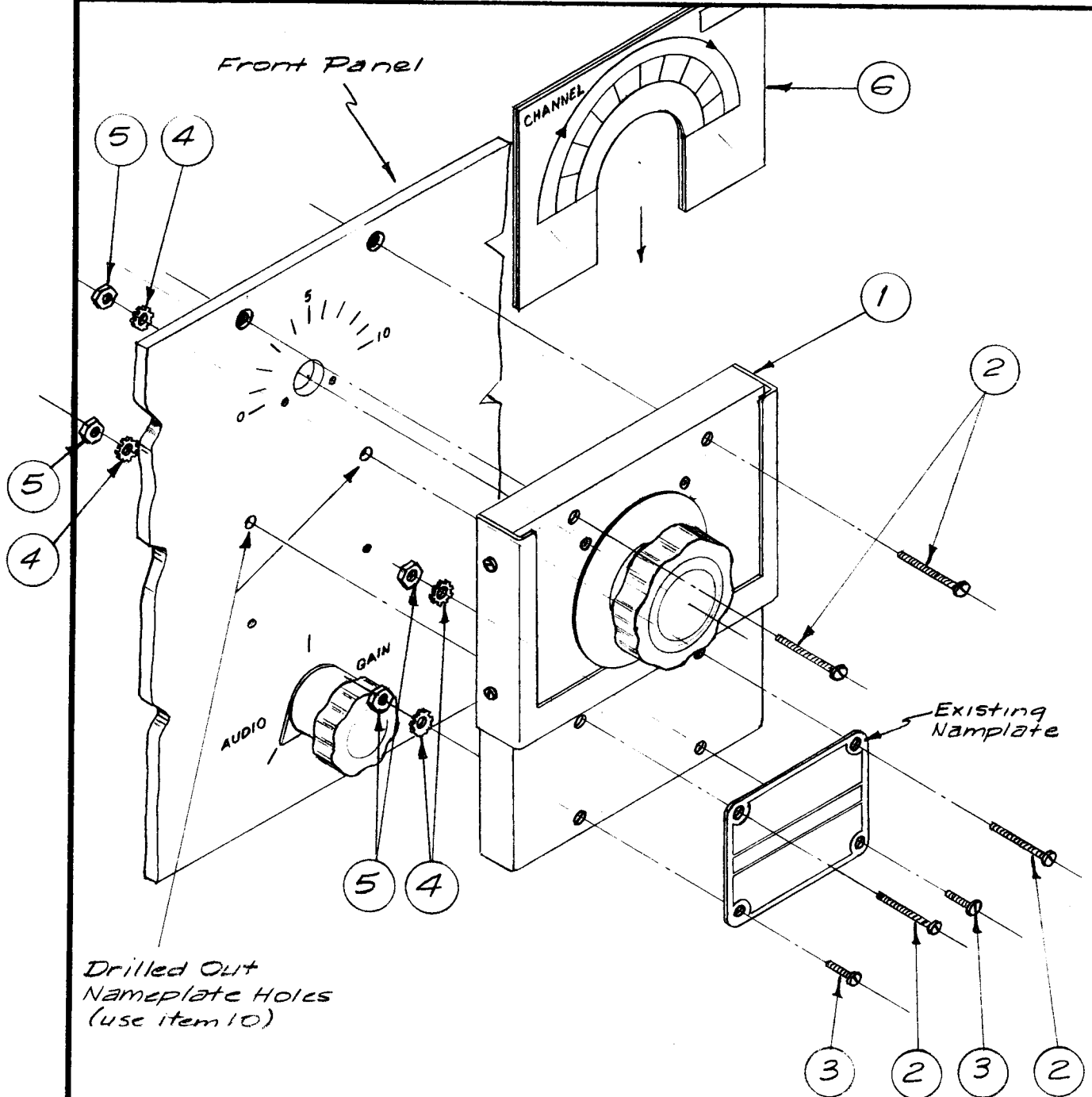

MAIN TUNING DIAL ASSEMBLY

FIGURE 1

DATE _____
SH. 4 OF 10
COMPILED BY _____

TMC SPECIFICATION NO. S

TITLE: _____

JOB REV. A

APPROVED _____

MODIFICATION KIT, TMC NO. 143

8. Original HFO Tuning Control

- a. Turn the Original HFO Tuning Knob (located on the left end of the panel) to the extreme clockwise position and remove the large skirt knob.
- b. Remove the shaft bushing nut and lockwasher.
- c. Remove the protective backing on the new R.F. Gain Dial Plate (item 7).
- d. Place the new R.F. Gain Dial on the bushing, center it on the two stop pins protruding through panel, and press the dial on the panel to allow adhesive backing to adhere.
- e. Replace the bushing lockwasher and nut and tighten.
- f. Install the Small Skirt Knob, which was taken from the old R.F. Gain Control (step 4), with the white scribe line pointing to 10 on the R.F. Gain Dial Plate.
- g. Loosen shaft coupling setscrews & rotate condenser clockwise to its closed position. At the same time, keep the knob shaft stop pin against the right hand stop. Tighten set screws.

9. BFO Control

- a. Turn the BFO Control Knob to the extreme counter-clockwise position and remove the large skirt knob.
- b. Remove the bushing nut and lockwasher.
- c. Remove the protective backing on the new BFO Dial Plate (item 8).
- d. Place the new BFO Dial on the bushing, center it on the two stop pins protruding through the panel, and press the dial on the panel to allow the adhesive backing to adhere.
- e. Replace the bushing lockwasher and nut and tighten.
- f. Install the new Small Skirt Knob (item 9) on the shaft with the white scribe line pointing to the 5 on the left side of of the BFO Dial.

10. Rewiring Control Circuits.

- a. Referring to the New Controls, R.F. Gain and Main Tuning, remove the three leads from the variable condensers. Remove the other ends of the leads from the terminals on 22 and 23.
- b. Substitute the six new leads, numbered 1 to 6 (items 11 to 16) for those removed, which then cross connect the "2" Ass m-7 bles to the proper variable condensers. Connect the leads as shown in Figure 2.
- c. Check Frequency of Oscillator according to Instruction Manual, Corrective Equipment Maintenance, Model RSC, Section 1C, Page 4-11.

DATE _____
SH. 5 OF 10
COMPILED BY _____

TMC SPECIFICATION NO. S

TITLE: _____

JOB REV. A

APPROVED _____

MODIFICATION KIT, TMC NO. 143

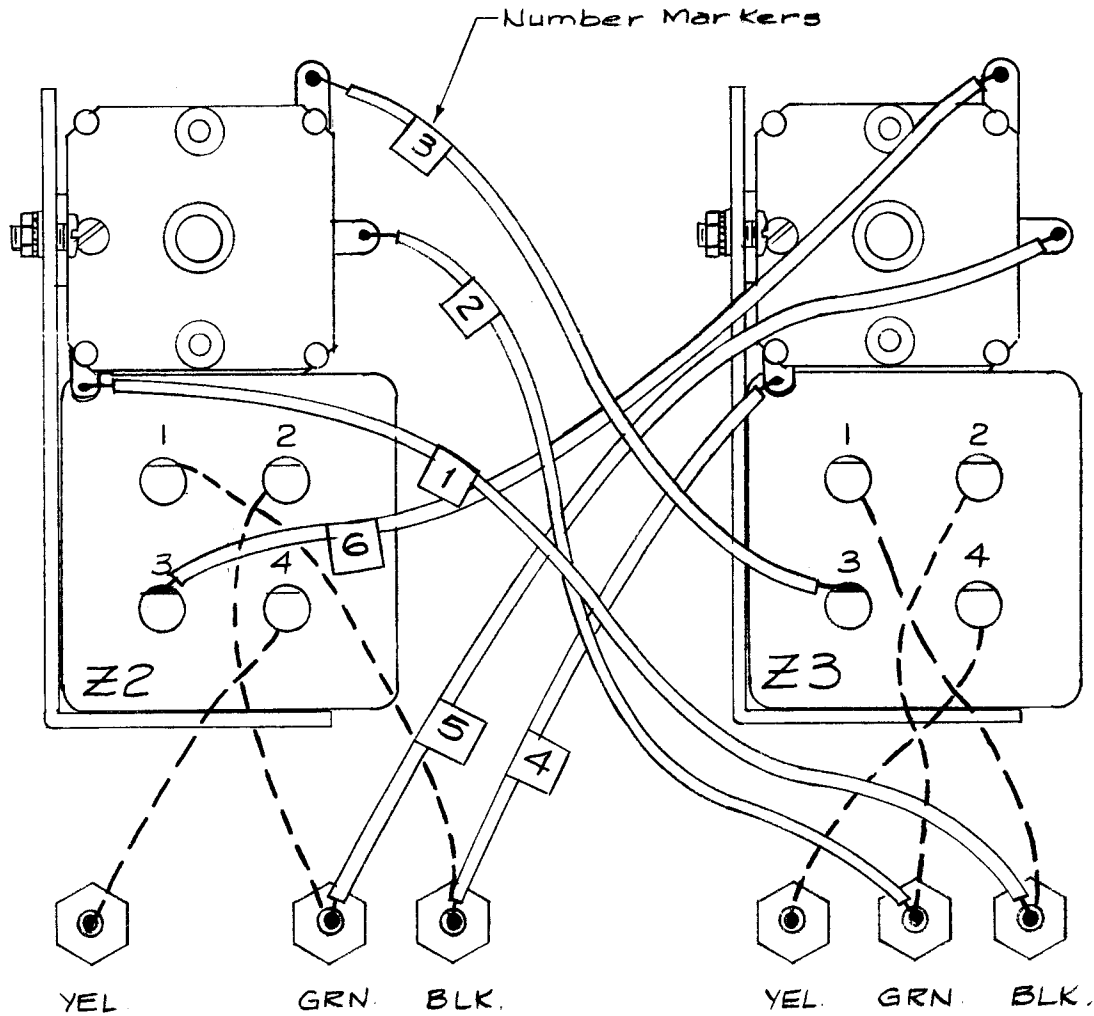

Note: Dotted Lines Indicate Existing Wires in Unit which Will not be changed.

VIEWED FROM FRONT OF UNIT

REWIRING CONTROL CIRCUITS

FIGURE 2

DATE 10-23-58
SH. 6 OF 10
COMPILED BY

TMC SPECIFICATION NO. S - 395

TITLE: RSC-2 to RSC-3 MODIFICATION KIT

JOB REVA

APPROVED

MODIFICATION KIT, TMC NO. 143

B. Loudspeaker Replacement:

1. Items Required (Supplied in Kit)

Item
No.

1. One each MS-1388, Transformer Mounting Bracket.
 2. One each LS-104, Loudspeaker.
 3. Two each TE-117-31, Spacer, $\frac{1}{2}$ " long, $\frac{1}{4}$ " diameter.
 4. One each 5/32" Diameter drill.
 5. Two each SCBSQ44OBC14, Screw, 4-40 X 7/8" long.
 6. Two each LWEO4MRC, Lockwasher, No. 4.
 7. Two each NTHO44OBC8, Nut, Hexagon, 4-40 Threads.
 8. 6' of WL-100-7, Buss Wire, No. 22.
 9. One each CA-401-6-7-4, Cable, Insulated, No. 22, Blue, 4" long, marked with No. 7.
2. Remove shields and tubes No's V7, V8, V9, V10, V11, V12, and R51.
 3. Carefully unsolder the black and the white leads from the loudspeaker terminals,
 4. Remove the loudspeaker and perforated plate from the Front Panel.
 5. Remove the red lead which connects R49 to terminal 8 of T5.
(save red sleeving).
 6. Remove the bare ground lead from terminal 5 of T5.
 7. Connect and solder a 2- $\frac{1}{2}$ " length of No. 22 buss wire, WL-100-7 (item 8), on terminal 4 of T5.
 8. Connect and solder a 3- $\frac{1}{2}$ " length of No. 22 buss wire, (item 8) on terminal 8 of T5. Cover wire with original red sle ving from Step 5.
 9. Unsolder the blue lead (coming from the cable) from terminal 3 of T5, being careful not to overheat the lead so that a short in its shield results.
 10. Remove the blue lead from terminal 7 of T5 and Pin 1 of V8.
 11. Connect and solder the 4 inch blue lead (item 9) on terminal 7 of T5.
 12. Remove the 4 screws, nuts, and lockwashers which hold down T5.
 13. Locate two "A" holes as shown in Figure 3. Drill out with 5/32" drill (item 4), being careful not to damag any leads on the underside of chassis.

DATE _____
SH. 7 OF 10
COMPILED BY _____

TMC SPECIFICATION NO. S

TITLE: _____

JOB REVA

APPROVED _____

MODIFICATION KIT, TMC NO. 143

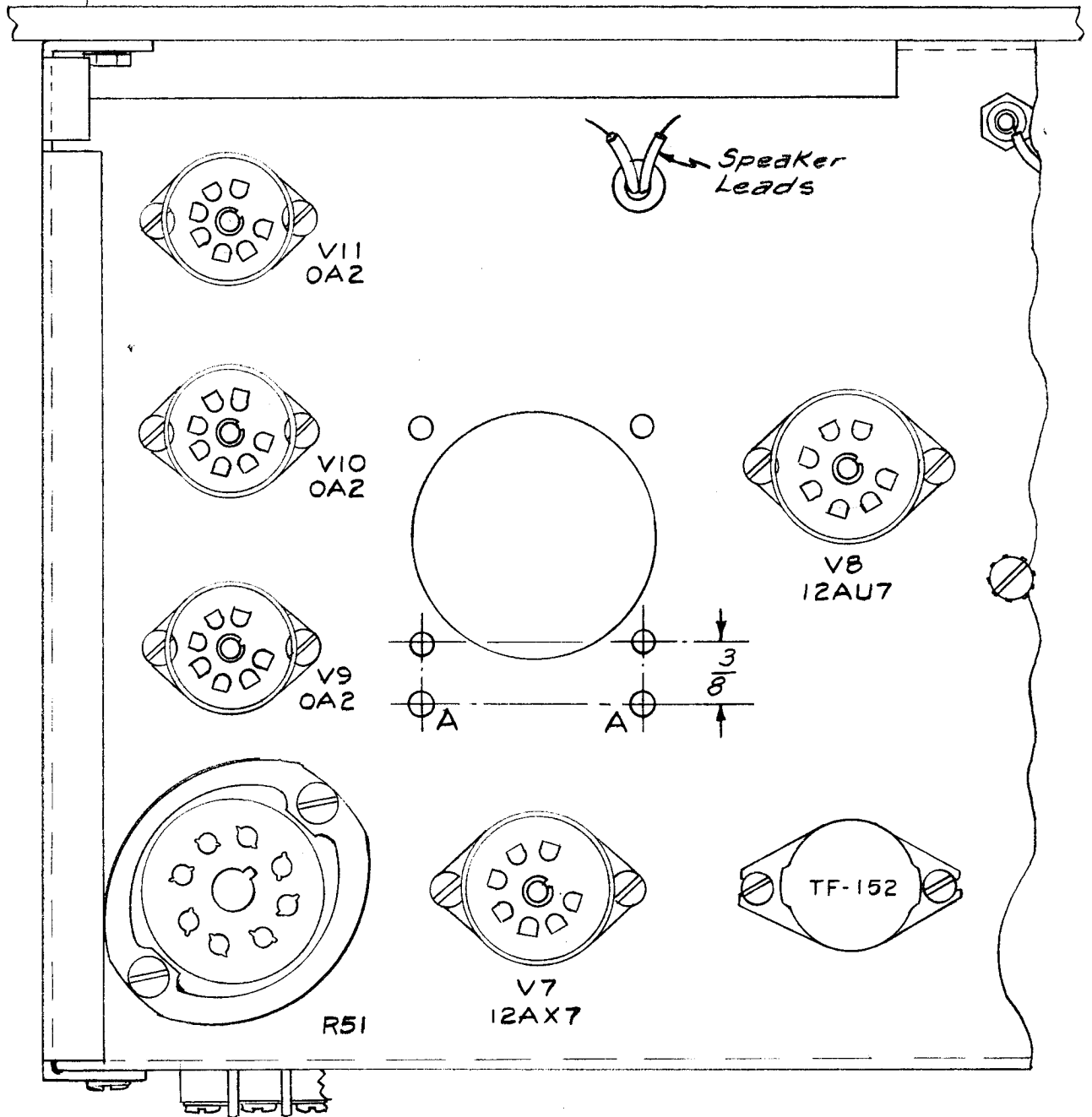

LOCATE AND DRILL OUT TWO "A" HOLES WITH 5/32 DRILL AS PER STEP 12.

FIGURE 3

DATE 10-23- 58
SH. 8 OF 10
COMPILED BY

TMC SPECIFICATION NO. S- 395

TITLE: RSC-2 to RSC-3 MODIFICATION KIT

JOB REV. A

APPROVED

MODIFICATION KIT, TMC NO. 143

14. Mount bracket, MS-1388 (item 1) on Transformer, T5, as shown in Figure 4, using two of the existing original 4-40 mounting screws, nuts, and lockwashers.
15. Mount the bracket and transformer Assembly on the chassis as shown in Figure 4, using the other two original 4-40 mounting screws, nuts and lockwashers.
16. Mount the rear end of T5 on two spacers, TE-117-31 (item 3), with two 4-40 screws, SCBS040BC14 (item 5), two lockwashers, LWE04MRC (item 6), and two nuts, NTH040BC8 (item 7).
17. Connect and solder the red covered lead from terminal 8 of T5 (step 8) to common end of R48, R49, and R50.
18. Connect and solder the 2- $\frac{1}{2}$ " buss wire from terminal 4 of T5 (step 7) to ground terminal on V9 Socket.
19. Connect and solder the blue lead from cable, which was on terminal 3 of T5 (step 9), to terminal 2 of T5.
20. Connect and solder the 4 inch blue lead from terminal 7 of T5 (step 11) to pin 1 of V8.
21. Mount Loudspeaker, IS-104 (item 2) on Front Panel as shown in Figure 5, using original mounting hardware and perforated plate.
22. Connect and solder the black and the white leads to speaker terminals.
23. Replace tubes and shields in their correct sockets.

DATE _____
SH. 9 OF 10
COMPILED BY _____

TMC SPECIFICATION NO. S

TITLE: _____

JOB REV A

APPROVED _____

MODIFICATION KIT, TMC NO. 143

NOTE:
Item No. 1, MS-138B, Bracket, Quan. 1,
Item No. 3, TE-117-31, Spacer, Quan. 2,
Item No. 5, SCBS0440BC14, Screw, Quan. 2,
Item No. 6, LWED4MRC, Lockwasher, Quan. 2,
& Item No. 7, NTH0440BCB, Nut, Quan. 2
Supplied With Modification Kit.
All Other Items Shown are
Existing Items.

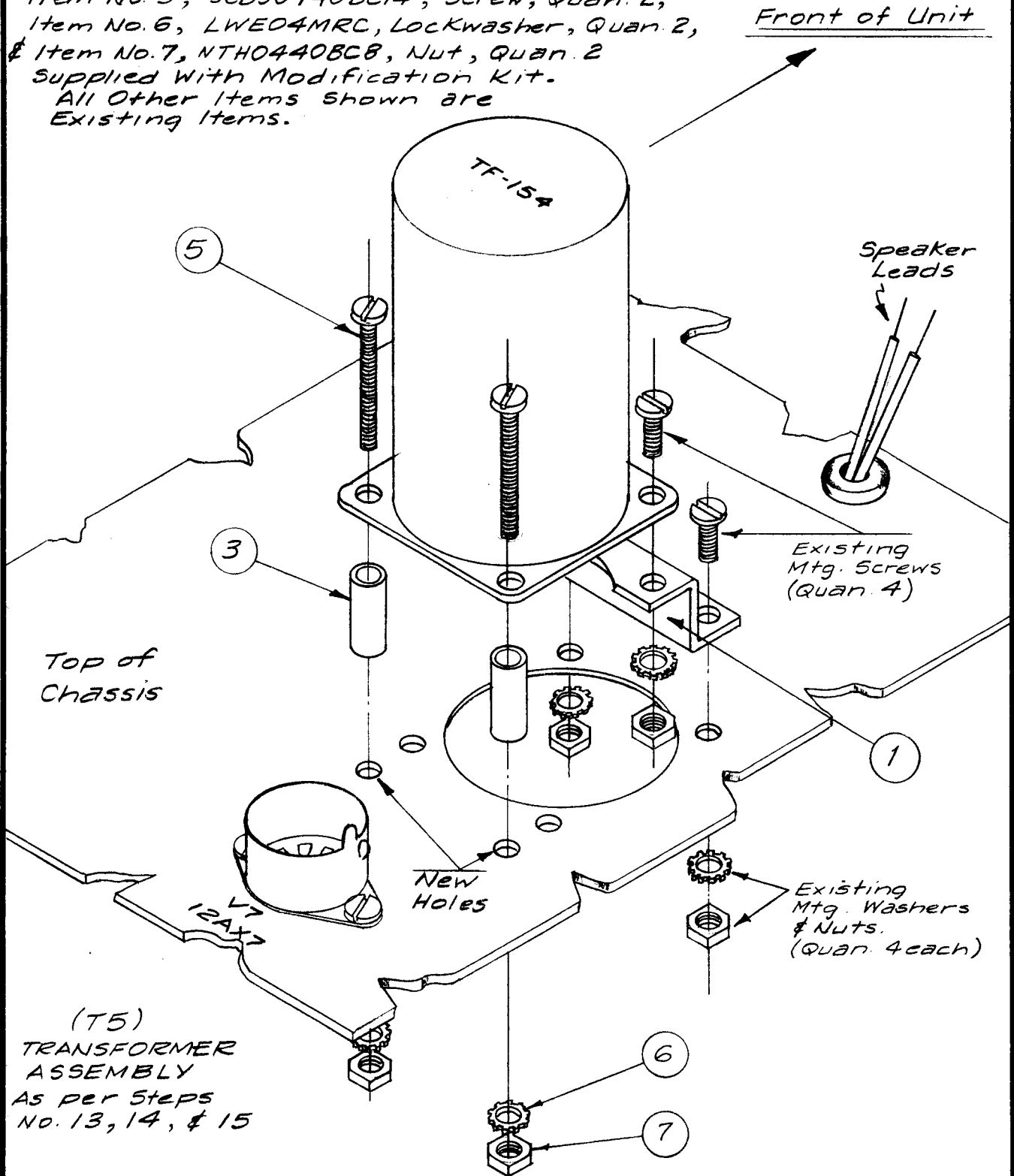

FIGURE 4

DATE _____
SH. 10 OF 10
COMPILED BY _____

TMC SPECIFICATION NO. S

TITLE:

JOB RELIA

APPROVED

MODIFICATION KIT, TMC NO. 143

REAR VIEW OF UNIT
All Components Deleted from Chassis for Clarity.

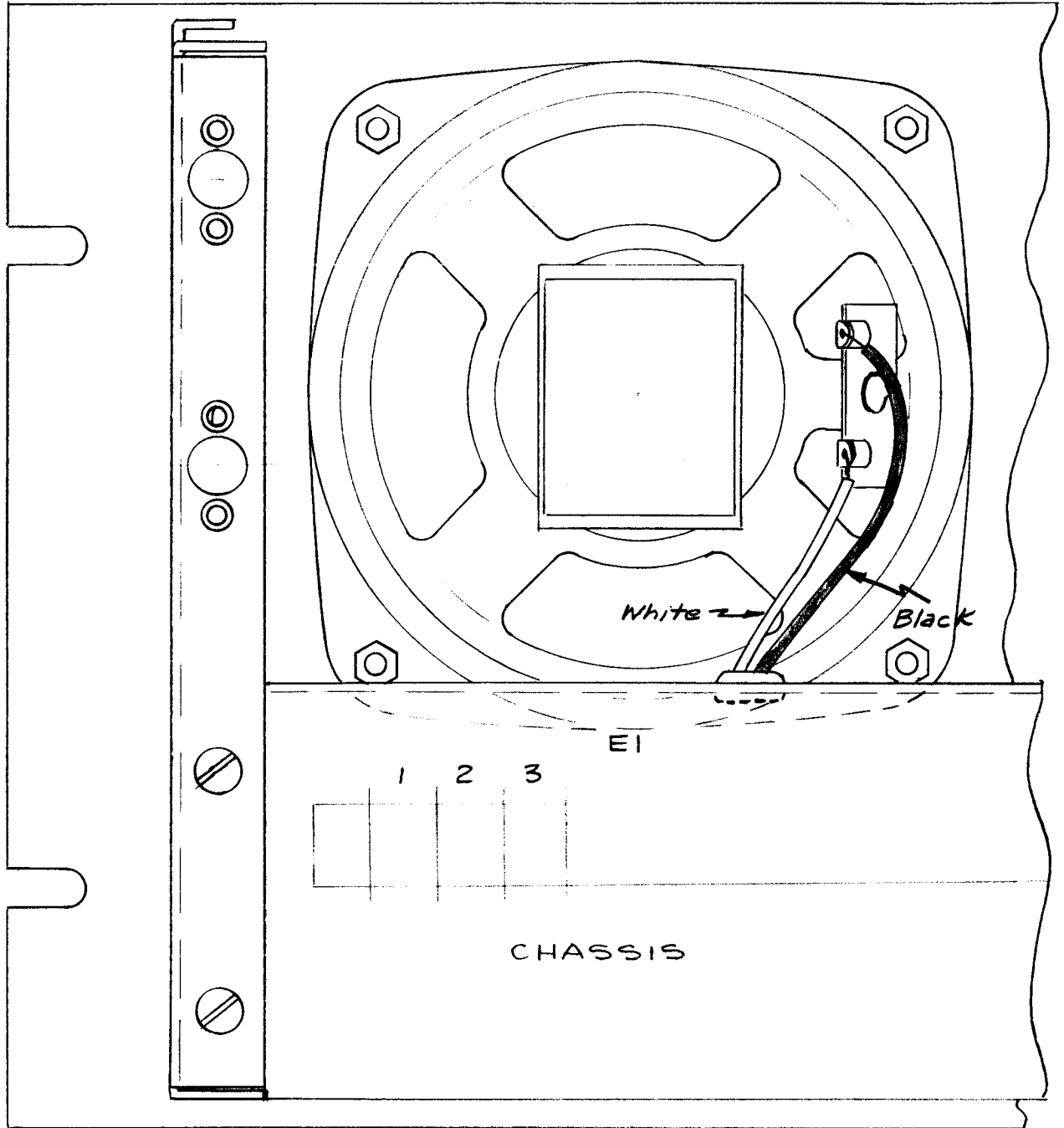

LOUDSPEAKER (LS-104) MOUNTING AS PER STEPS 20 and 21.

FIGURE 5

