

REQ. PER. UNIT	USED ON			TT-154
	MODEL	ASSY. NO.	DATE	
1	GPR-92		9-8-51	

SPECIFICATIONS

Q- SEC.- 55 OR GREATER\*  
 PRI.- 50 OR GREATER

L UH- SEC.-190\*  
 PRI.-220

FREQ- SEC.-790KC  
 PRI.-790KC

\* WITHOUT TUNING CORE

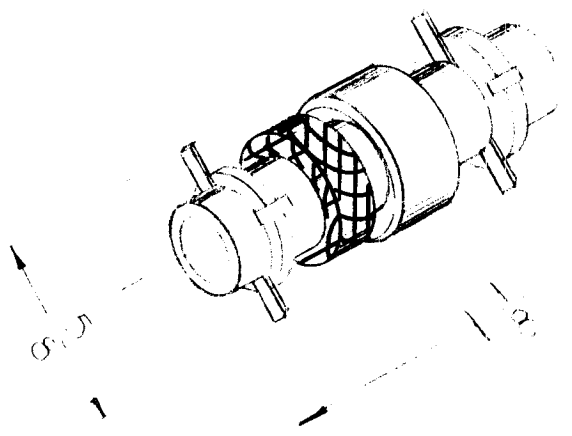

SCHEMATIC

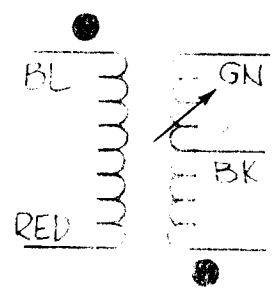

● INDICATES START OF WINDING

							REQ. ITEM	PART NO.	STROMER	DESCRIPTION	SYMBOL		
							STOCK SIZE		THE TECHNICAL MATERIEL CORP. MAMARONECK, NEW YORK				
							MATERIAL		TRANSFORMER, 2F TUNED				
ORIGINAL RELEASE FOR PRODUCTION							1-2165	2L	RUIZZA		RSC		
ISSUE	ITEM	CHANGED FROM	DATE	CH. NO.	DRAFTS	CHECKER	ENG. APP.	TYPE & TEMPER		HEATTREAT. SPEC.	DRAWN	CHECKED	FINAL APPROVAL
TOLERANCES			SCALE: 2A-2139				FINISH & SPEC. NO.		ELEC. DES. APP		MECH. DES. APP		TT-154
DEC. DIM. ± FRAC. DIM. ± ANGULAR DIM. ±			MAXIMUM ALLOWABLE TOLERANCES HAVE BEEN DETERMINED AND ANY DEVIATIONS WILL BE CAUSE FOR REJECTION. REMOVE ALL BURRS AND SHARP EDGES										