



TECHNICAL MANUAL

**FOR
ANTENNA MULTICOUPLER**

MODEL AMC-8A

THE TECHNICAL MATERIEL CORPORATION

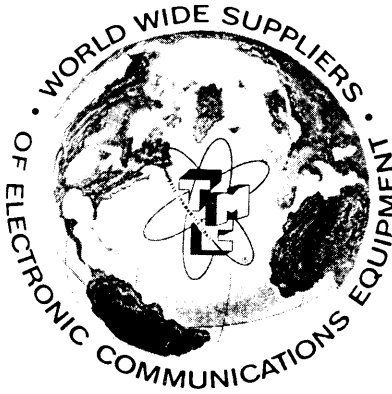

TECHNICAL MANUAL

FOR

ANTENNA MULTICOUPLER

MODEL AMC-8A

PUBLICATION NUMBER

120-040100-007

ISSUE DATE

JANUARY 1980

THE TECHNICAL MATERIEL CORPORATION

CABLE: TEPEI

700 FENIMORE ROAD, MAMARONECK, NY 10543 U.S.A.

TLX: 137-358

TEL: 914-698-4800

TWX: 710-566-1100

NOTICE

THE CONTENTS AND INFORMATION CONTAINED IN THIS INSTRUCTION MANUAL IS PROPRIETARY TO THE TECHNICAL MATERIEL CORPORATION TO BE USED AS A GUIDE TO THE OPERATION AND MAINTENANCE OF THE EQUIPMENT FOR WHICH THE MANUAL IS ISSUED AND MAY NOT BE DUPLICATED EITHER IN WHOLE OR IN PART BY ANY MEANS WHATSOEVER WITHOUT THE WRITTEN CONSENT OF THE TECHNICAL MATERIEL CORPORATION.

RECORD OF REVISIONS

NO.	ISSUED	DESCRIPTION	EMN ENTERED	BY
001	3-6-80	A5780 REPLACES FI10001(2)	R.U.	
002	3-17-80	page 1-3, Dist. Gain was .5 -P/S was 20w	R.U.	
003	6-17-80	Replace pages 6-2, 5-5, 7-1	21814	R.U.
004	7-10-80	Replace pages 6-2, ii, 4-4, 7-1, 5-5, add 7-7	21817	R.U.
005	6-25-81	REPLACE PAGES 5-9, 6-4, 7-4	21886	
006	10-8-81	PAGES 4-4, 5-5, 6-2, 7-1, 7-7	21892	RU
007	2-11-82	REPLACE PAGES 5-10, 5-6, 7-1, 4-4, 5-5	21910	RU
008				
009				
010				

NOTE: Please file Technical Newsletters at back of manual for permanent record.

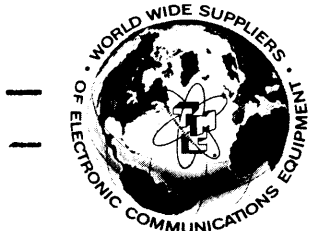

THE TECHNICAL MATERIEL CORPORATION

C O M M U N I C A T I O N S E N G I N E E R S

700 FENIMORE ROAD

MAMARONECK, N. Y.

W a r r a n t y

The Technical Materiel Corporation, hereinafter referred to as TMC, warrants the equipment (except electron tubes, *fuses, lamps, batteries and articles made of glass or other fragile or other expendable materials) purchased hereunder to be free from defect in materials and workmanship under normal use and service, when used for the purposes for which the same is designed, for a period of one year from the date of delivery F.O.B. factory. TMC further warrants that the equipment will perform in a manner equal to or better than published technical specifications as amended by any additions or corrections thereto accompanying the formal equipment offer.

TMC will replace or repair any such defective items, F.O.B. factory, which may fail within the stated warranty period, PROVIDED:

1. That any claim of defect under this warranty is made within sixty (60) days after discovery thereof and that inspection by TMC, if required, indicates the validity of such claim to TMC's satisfaction.
2. That the defect is not the result of damage incurred in shipment from or to the factory.
3. That the equipment has not been altered in any way either as to design or use whether by replacement parts not supplied or approved by TMC, or otherwise.
4. That any equipment or accessories furnished but not manufactured by TMC, or not of TMC design shall be subject only to such adjustments as TMC may obtain from the supplier thereof.

Electron tubes furnished by TMC, but manufactured by others, bear only the warranty given by such other manufacturers. Electron tube warranty claims should be made directly to the manufacturer of such tubes.

TMC's obligation under this warranty is limited to the repair or replacement of defective parts with the exceptions noted above.

At TMC's option any defective part or equipment which fails within the warranty period shall be returned to TMC's factory for inspection, properly packed with shipping charges prepaid. No parts or equipment shall be returned to TMC, unless a return authorization is issued by TMC.

No warranties, express or implied, other than those specifically set forth herein shall be applicable to any equipment manufactured or furnished by TMC and the foregoing warranty shall constitute the Buyers sole right and remedy. In no event does TMC assume any liability for consequential damages, or for loss, damage or expense directly or indirectly arising from the use of TMC Products, or any inability to use them either separately or in combination with other equipment or materials or from any other cause.

*Electron tubes also include semi-conductor devices.

TABLE OF CONTENTS

<u>Paragraph</u>		<u>Page</u>
	<u>SECTION 1 - GENERAL DESCRIPTION</u>	
1-1	Functional Description	1-1
1-2	Physical Description	1-1
1-3	Equipment Supplied	1-3
1-4	Technical Specifications	1-3
	<u>SECTION 2 - INSTALLATION</u>	
2-1	Initial Inspection	2-1
2-2	Power Requirements and Electrical Installation	2-1
2-3	Performance Check	2-2
	<u>SECTION 3 - OPERATION</u>	
3-1	General	3-1
	<u>SECTION 4 - PRINCIPLES OF OPERATION</u>	
4-1	General	4-1
4-2	RF Input Filter	4-1
4-3	Preamplifier and Outputs	4-1
4-4	Power Supply and Regulator	4-2
	<u>SECTION 5 - MAINTENANCE</u>	
5-1	General	5-1
5-2	Preventive Maintenance	5-1
5-3	Troubleshooting	5-2
5-4	Repair	5-3
5-5	Adjustments	5-4

TABLE OF CONTENTS (cont.)

<u>Paragraph</u>		<u>Page</u>
	<u>SECTION 6 - PARTS LIST</u>	
6-1	Introduction	6-1
6-2	Note	6-1
	<u>SECTION 7 - SCHEMATICS</u>	

LIST OF ILLUSTRATIONS

<u>Figure</u>		<u>Page</u>
1-1	Eight Output Antenna Multicoupler, Model AMC-8A	1-0
2-1	Rear Panel, AMC-8A	2-3
4-1	Block Diagram, AMC-8A	4-4
5-1	Top View With Cover Off, AMC-8A	5-5
5-2	Power Supply (Regulator) Assembly 1A1	5-6
5-3	Bandpass Filter (FX10018-1) Assembly 1A2	5-7
5-4	Bandpass Filter (FX10034) Assembly 1A2	5-8
5-5	Preamplifier Assembly 1A3	5-9
5-6	8 Output Assembly 1A4	5-10
7-1	System Schematic, AMC-8A (1)	7-1
7-2	Power Supply (Regulator) Schematic (1A1)	7-2
7-3	Bandpass Filter Schematic (1A2)	7-3
7-4	Preamplifier Schematic (1A3)	7-4
7-5	8 Output Schematic (1A4)	7-5
7-6	A5780 AC Filter Assembly (FL1)	7-6
7-7	A5782 Transformer Assembly T1, T2	7-7

LIST OF TABLES

<u>Table</u>		<u>Page</u>
1-1	Semiconductor and Integrated Circuit Complement	1-2
1-2	Loose Items Supplied	1-3
3-1	Controls and Indicators	3-1

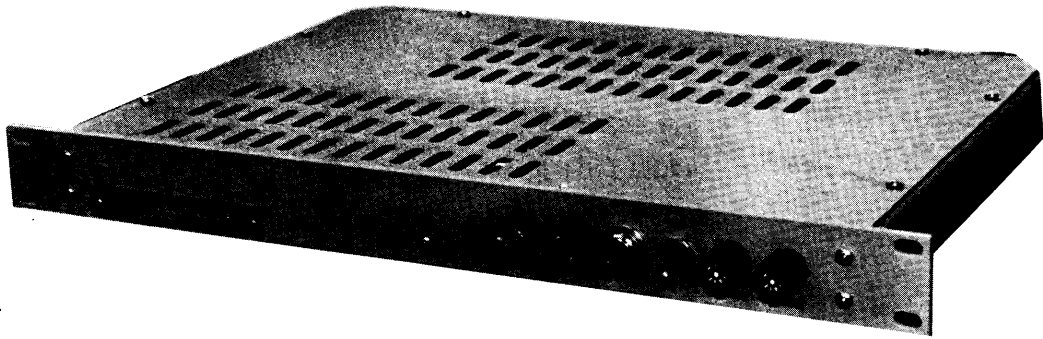

Figure 1-1

EIGHT OUTPUT ANTENNA MULTICOUPLER, MODEL AMC-8A

SECTION 1
GENERAL INFORMATION

1-1. FUNCTIONAL DESCRIPTION

(1) The Eight Output Antenna Multicoupler, Model AMC-8A (figure 1-1) is a broadband Antenna-to-Receiver coupling device which permits the use of a common antenna by eight communications receivers. Its circuitry consists of a bandpass filter, a broadband transistorized preamplifier, and eight individual buffer amplifiers. The unit is engineered in such a way that a sizeable reduction is achieved in the amplitude of signals re-radiated from one receiver to another or from one receiver to the common antenna system. The AMC-8A is provided with a bandpass filter which passes frequencies between 2 MHz and 32 MHz.

(2) The filter attenuates all signals outside the band to avoid needless overloading of amplifiers due to large signals outside the band of interest.

(3) The amplifier including buffers, has a low noise figure and yet large signal handling capability. It yields +2 dB overall insertion gain without introducing objectionable intermodulation. In addition, it provides a constant input and output impedance for a good VSWR over 2 to 32 MHz, and high isolation between output to output or output to input to suppress re-radiation from one receiver to another or to the common antenna system.

1-2. PHYSICAL DESCRIPTION

(1) The AMC-8A is designed for mounting in a standard 19 inch rack, fastened by four retaining screws on the front panel. The operating controls are located on the front panel. The eight output receptacles are on the rear panel as are the power connections.

The majority of the components in the AMC-8A are mounted on printed circuit boards which in turn are bolted to the chassis. Other components are bolted directly to the chassis. All semiconductors used in the AMC-8A are listed in table 1-1.

Table 1-1. SEMICONDUCTOR AND INTEGRATED CIRCUIT COMPLEMENT

Reference Symbol	Type	Function
Power Supply		
1Z1	NW10005	Rectifier Bridge
1A1CR1	1N758	Bias Regulator
1A1CR2	1N914B	Bias Regulator
1A1Q1	TX10001	Current Regulator
1A1Q2	2N5086	Voltage Regulator
1Q1	2N3055	Voltage Regulator
Preamplifier (50 or 75 ohm)		
1A3CR1	1N914B	Bias Regulator
1A3Q1	2N5160	Buffer
1A3Q2	2N5160	Current Amplifier
1A3Q3	2N3866	Current Amplifier
8 Buffer Amplifiers		
1A4Q11 to 1A4Q81	2N3866	Buffers

1-3. EQUIPMENT SUPPLIED

(1) The following table is a list of ancilliary items supplied with each AMC-8A.

Table 1-2. LOOSE ITEMS SUPPLIED

Name	Designation	Function	Qty
Power Cable Assy	CA10505	Connections to power connector 1J10	1
Technical Manual	_____	Instructions for operating and maintenance of AMC-8A	1

1-4. TECHNICAL SPECIFICATIONS

Number of outputs:	Eight
Frequency Range:	2 MHz to 32 MHz
Input and output impedance:	50 or 75 ohms with a VSWR better than 1.5
Distortion gain:	2 dB \pm 0.25
Desensitization:	100 uV signal is compressed by 3 dB maximum when an 8 V peak-to-peak signal between 2 to 6 MHz is applied at the same time.
Off-band rejection:	-30 dB minimum from dc to 1.4 MHz and from 46 MHz to 1 GHz.
Noise figure:	7 dB maximum
Intermodulation:	With two 0.5 volts rms input signals 2nd order products, -65 dB 2 to 20 MHz. -60 dB 20 to 30 MHz. 3rd order products, -70 dB 2 to 30 MHz.
Isolation:	-40 dB minimum, output-to-output. -55 dB minimum, output-to-input.
Phase difference:	\pm 2 degrees between any two outputs.
Line filters:	-40 dB minimum attenuation, 14 KHz to 150 MHz.
Power Supply:	115 v \pm 6%, 48/62 Hz, power consumption approximately 30 watts.

TECHNICAL SPECIFICATIONS (cont.)

Dimensions:	Width 19 inches Height 13/4 inches Depth 14 inches
Weight:	8 pounds approximately
MTBF:	20,000 hours average operational life.
Temperature Range:	Class 4 military requirements, operating 0 ^o to 50 ^o C non-operating -62 ^o to +75 ^o C
Humidity:	Operational up to 95%.

SECTION 2 INSTALLATION

2-1. INITIAL INSPECTION

(1) Each AMC-8A is thoroughly tested and calibrated at the factory before being shipped. Upon receipt of the unit, check the packing case and its contents for possible damage. Unpack the equipment methodically taking care also to check the packing material for parts shipped as loose items. See table 1-2 for these. With respect to damaged equipment for which the carrier is liable, TMC will assist in describing methods of repair as well as furnishing of replacement parts.

2-2. POWER REQUIREMENTS & ELECTRICAL INSTALLATION

(1) The AMC-8A operates from a 115 volt ac, 50 to 60 Hz power source. The input is protected by two 0.5 amp fuses, one on each side of the line.

(2) The following external connections must be made to the AMC-8A.

(a) Antenna: Attach a BNC connector to a coaxial cable and connect it to antenna jack 1J9 (ANTENNA INPUT) on the rear panel of the AMC-8A. The other end is connected to an antenna.

(b) Power: Connect primary power to the unit by plugging the supplied power cable assembly into connector 1J10 (POWER INPUT) on the rear panel ensuring that the notch on the cable lines up with the pin at the top of 1J10.

(c) Outputs: Connect the outputs to the associated receivers as required via the BNC connectors, 1J1 to 1J8 inclusive, on the rear panel.

(3) All AMC-8A equipment should be located in such a way that sufficient clearance is obtained at the rear of the unit for making connections to the BNC connectors.

The front panel controls should be within easy reach of an operator. Solid state design eliminates heat problems allowing the stacking of several AMC-8A's one above the other in a rack.

2-3. PERFORMANCE CHECK

(1) When the AMC-8A has been installed and appropriate power connections have been made, turn POWER switch to the ON position. If the POWER lamp lights the Eight Output Antenna Multicoupler, Model AMC-8A is ready for use.

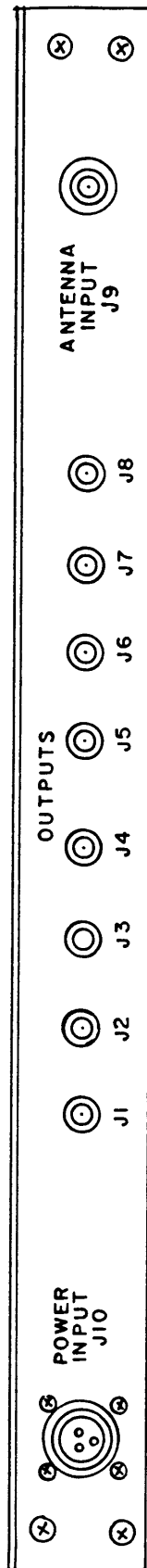

Figure 2-1
Rear Panel AMC-8A

SECTION 3
OPERATION

3-1. GENERAL

(1) Controls: Table 3-1 contains a list of the operating, indicators and fuse holders on the front panel of the AMC-8A.

Table 3-1. CONTROLS AND INDICATORS

Item	Description
Power ON/OFF switch 1S1	Controls primary power to AMC-8A
POWER lamp 1DS1	Lights when primary power is connected to the AMC-8A and switch 1S1 is turned on.
Fuse holders for 1F1/1F2	Failure of a fuse is indicated by illumination of the FUSE holder.
SPARE fuses	Two spare fuses are contained in storage holders located on the front panel.

(2) Procedures: Operating procedures for the AMC-8A are virtually non-existent. After the necessary connections have been made from the rear panel to the appropriate receiver the only procedure to perform is to turn on the power switch.

SECTION 4
PRINCIPLES OF OPERATION

4-1. GENERAL

(1) The Eight Output Antenna Multicoupler is a broadband distribution system designed to operate between a single antenna and the antenna terminating points of eight communications receivers. Both the input and output impedance (50 or 75 ohms) of the AMC-8A are flat over the specified operating frequency range to ensure high performance when used in a communications receiving system. Four major circuits comprise the AMC-8A and they are described in the succeeding paragraphs in this section. See figure 4-1, Block Diagram, AMC-8A for further comprehension.

4-2. INPUT FILTER(FX10018-1 - 75 ohm, FX10034 - 50 ohm)

(1) The antenna input is connected to a bandpass filter mounted on its own printed circuit assembly 1A2 via ANTENNA INPUT connector 1J9. This filter is a seven pole bandpass type for frequencies between 2 to 32 MHz and has high attenuation to frequencies outside the bandpass range. All input signals pass through this filter before being fed via shielded cable to the preamplifier.

(2) A neon lamp 1A2DS1 is connected across the input. It prevents damage to components of the AMC-8A caused by lightning surges in the antenna. Any voltage over 40 volts will cause the lamp to fire redirecting the surge to ground.

4-3. PREAMPLIFIER AND OUTPUTS

(1) The preamplifier printed circuit assembly 1A3 encompasses on it a low noise, wideband amplifier having an input impedance of 50 or 75 ohms and a voltage gain of 8 db. The input to the preamplifier circuit is applied to step-up transformer 1A3T1.

The voltage level across the output of 1A3T1 is fed through buffer amplifier 1A3Q1 to a complimentary push-pull amplifier circuit consisting of 1A3Q2 and 1A3Q3. The latter circuit acts as a balancing circuit minimizing second order intermodulation products at the preamplifier output. The output signal appears at the output terminal after passing through dc blocking capacitor 1A3C7.

(2) The output signal is fed through external wiring from a terminal on the preamplifier printed circuit assembly 1A3 to an input terminal. This input terminal is on the 8 output printed circuit assembly 1A4, connected in common (through input capacitors 1A4C11 to 1A4C81 inclusive) with the inputs of 8 identical buffer amplifiers each of which has an output impedance of 50 or 75 ohms. Thus the original signal from the bandpass filter which was stepped-up 8 db by transformer 1A3T1, can be followed all the way through the pre-amplifier and output stages to appear at the emitter of each buffer amplifier transistor (1A4Q11 to 1A4Q81 inclusive). This level is attenuated about 6 db in each buffer by the output impedance matching circuit. For each of the 8 outputs an over-all insertion gain of +2 db is realized.

4-4. POWER SUPPLY AND REGULATOR

(1) The power supply components are chassis mounted except for the regulator which is described later. The primary power input to the AMC-8A is provided through a printed circuit filter assembly A5780 (FL1). A5780 removes RF signals present in the line. When the POWER switch 1S1 is in the ON position, input power lights lamp 1DS1 on the front panel and is fed through fuses 1F1 and 1F2 to the power transformer 1T1. This transformer reduces the line voltage to the required 27 vac. This potential in turn is rectified by 1Z1, a diode bridge and filtered by capacitor 1C1.

(2) Printed circuit assembly 1A1 performs a regulating function which provides a -27 vdc regulated output. Transistor 1Q1 and 1K potentiometer 1A1R7 provide the regulated voltage. This is set at the factory and seldom needs any adjustment. The power supply board also provides short circuit protection for the AMC-8A.

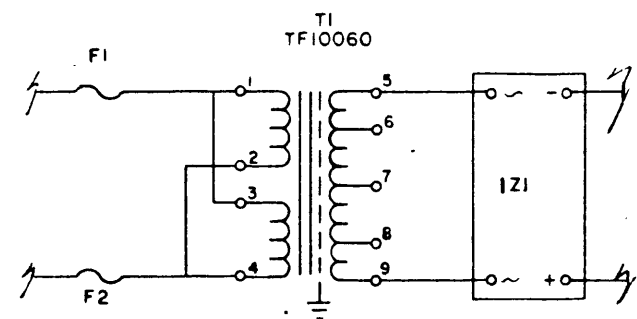
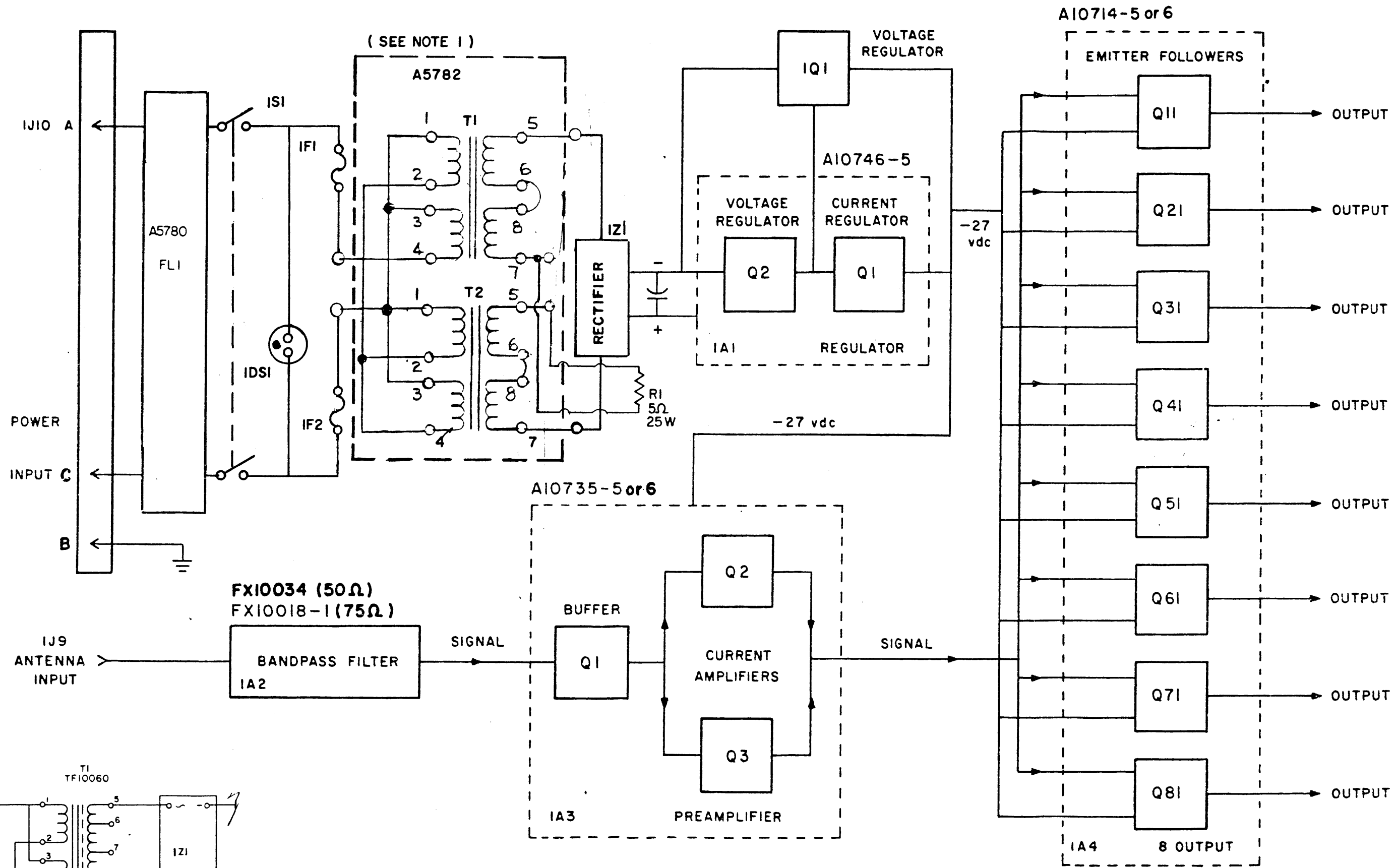

NOTE 1,
SOME UNITS MAY USE TF10060 IN PLACE
OF ASSEMBLY A5782 (T1, T2)

Figure 4-1
System Block Diagram, AMC-8A

SECTION 5
MAINTENANCE

5-1. GENERAL

(1) This section describes preventive maintenance, troubleshooting and repair procedures for the AMC-8A. The following equipment is suggested in order to perform these procedures properly.

- (a) RF Signal Generator, Hewlett Packard Model 606A, or equivalent.
- (b) Oscilloscope, Tektronix Model 545, or equivalent.

(2) For aid in the location of components, refer to figures 5-1 to 5-5 inclusive.

5-2. PREVENTIVE MAINTENANCE

(1) In regard to the AMC-8A preventive maintenance consists of routine functions such as visual inspection and cleaning. Cleaning is strongly recommended as dust may build up on components and not only reduce the efficiency of the coupler unit but also increase component wear. To facilitate cleaning the unit, use a vacuum cleaner or a compressed air hose.

(2) A simple visual check of the unit when it is opened up for servicing or cleaning will often pick up potential trouble and hence reduce downtime due to component wear or failure. Signs of trouble are; discoloration, warped printed circuit boards, and damaged wiring. Any deteriorating component should be replaced immediately. In addition all hardware should be checked for tightness.

5-3. TROUBLESHOOTING

(1) The primary objective of this procedure is to narrow the problem area to one or two sections of the AMC-8A. In order to minimize labor costs while locating the source of trouble, systematic troubleshooting will greatly speed up the process. During operation of the AMC-8A the following symptoms may be observed:

1. The failure of one or more outputs.
2. Weak or noisy signals in all receivers.
3. Weak or noisy signals in one receiver.
4. Complete loss of signals in all receivers.

(2) The following paragraphs contain information which may cause the four problem symptoms just mentioned. They could be construed as typical faults that could occur during normal operation of the AMC-8A.

(a) The failure of one or more outputs: If a low output is observed at one particular output when connected to a specific receiver, failure of that output stage is indicated. All semiconductors and discrete components in the malfunctioning output stage should be checked.

(b) Weak or noisy signals in all receivers: If this phenomenon persists in all receivers, a rough check of the antenna system is required. Connect the antenna lead-in directly to the antenna terminals of a receiver. If the weakness and/or noise disappears, check the preamplifier circuit of the AMC-8A.

(c) Weak or noisy signals in one receiver: When only one receiver in the system is involved, check these items:

1. The receiver unit itself.
2. The connections between the AMC-8A and the receiver.
3. Or the particular output section as outlined in paragraph (a).

(d) Complete loss of signals in all receivers: If the entire system fails, the method discussed in paragraph (b) may be used to determine if the trouble actually is in the AMC-8A. If this appears to be the case, check each stage of the AMC-8A unit. The best method of doing this is to apply a test signal to the ANTENNA input jack on the rear of the unit. Use an RF signal generator and trace the signal back through the equipment with an oscilloscope. Start this procedure at the output jacks and work backwards towards the input.

5-4. REPAIR

(1) Repair work generally consists of the replacement of an electrical component, but the following precautions should be observed:

(a) Always replace a defective component with its exact duplicate.

(b) Place any new component in the same position as the one it replaces. It's generally not good practice to attempt to alter the existing layout. This includes the running of any wire as well as discrete component replacement.

(c) Never attempt to solder with an iron having a power rating of more than 100 watts. Use a pair of long-nose pliers as a heat sink to offer protection while soldering.

(d) Extreme caution is called for whenever replacement of components is warranted because excessive heat applied to a board can cause the printed circuit wiring to lift off.

(e) Always double check any solder joints made as cold or loose solder connections can cause trouble at a later date.

5-5. ADJUSTMENTS

(1) There are three main areas in the AMC-8A circuitry that should be checked periodically and they may require adjustment. They are as follows:

(a) Regulator: There is a screwdriver adjustable potentiometer 1A1R7 on the regulator printed circuit assembly. An arrow on the schematic denotes clockwise adjustment which lowers the regulated output voltage. It adjusts to produce -27 vdc.

(b) Preamplifier: There is a screwdriver adjustable potentiometer 1A3R6 on the preamplifier printed circuit assembly. Both wires must be removed from pin 3 of preamplifier assembly 1A3 to insert a meter in series. The meter is connected between the 2 wires and pin 3 and is adjusted for 90 ma. An arrow on the schematic denotes clockwise adjustment which lowers the standing current of the complimentary circuit.

(c) RF Input Filter: Most of the adjustable elements in the AMC-8A are contained in the RF filter. These elements are in the form of trimmer capacitors which are of the piston type. THESE TRIMMERS SHOULD NOT BE ADJUSTED AT ANY TIME UNLESS IT HAS BEEN DEFINITELY DETERMINED THAT ADJUSTMENT IS NECESSARY. The input filter was aligned during manufacture and certain tuning procedures were carried out during phases of assembly. Therefore, complete realignment is impossible without physically removing certain parts from the printed circuit board and it is for this reason that the realignment of the filter should be carried out at the factory. This is particularly true for any equipment supplied on contracts where phase co-relation is required from unit to unit. For such units adjustments were made at the factory against a master standard.

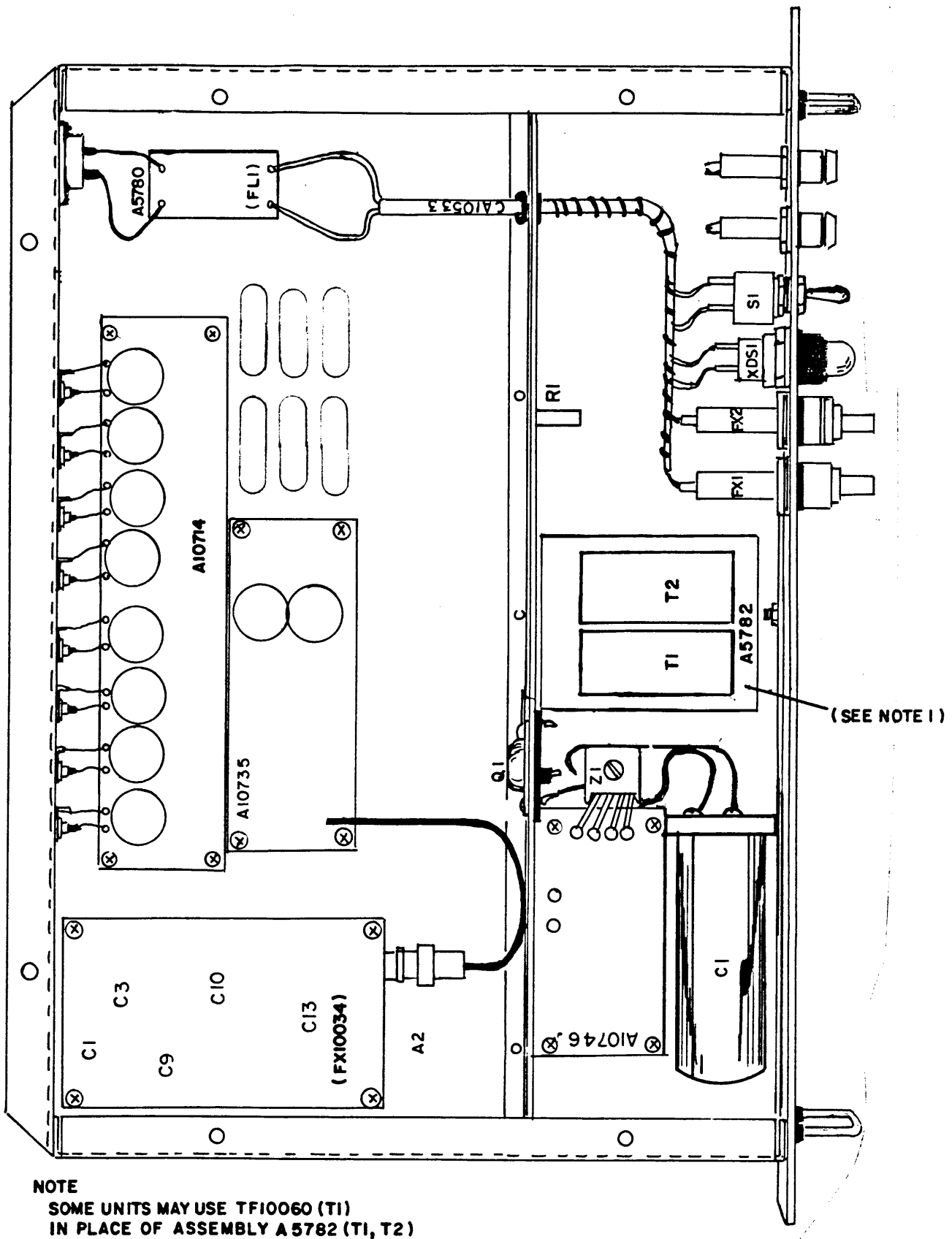

NOTE
 SOME UNITS MAY USE TF10060 (T1)
 IN PLACE OF ASSEMBLY A 5782 (T1, T2)

Figure 5-1
 Top View with Cover Off, AMC-8A

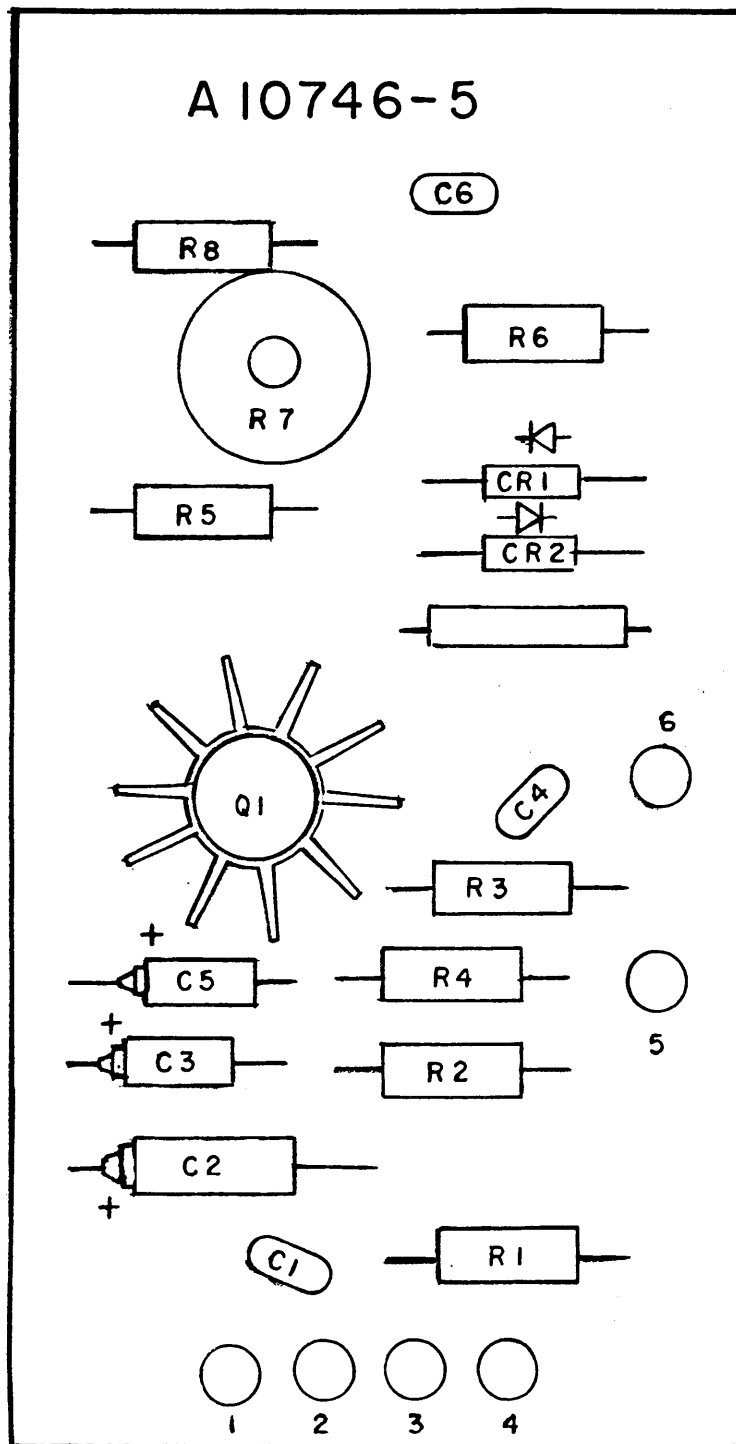

Figure 5-2

Power Supply (Regulator) Assembly 1A1

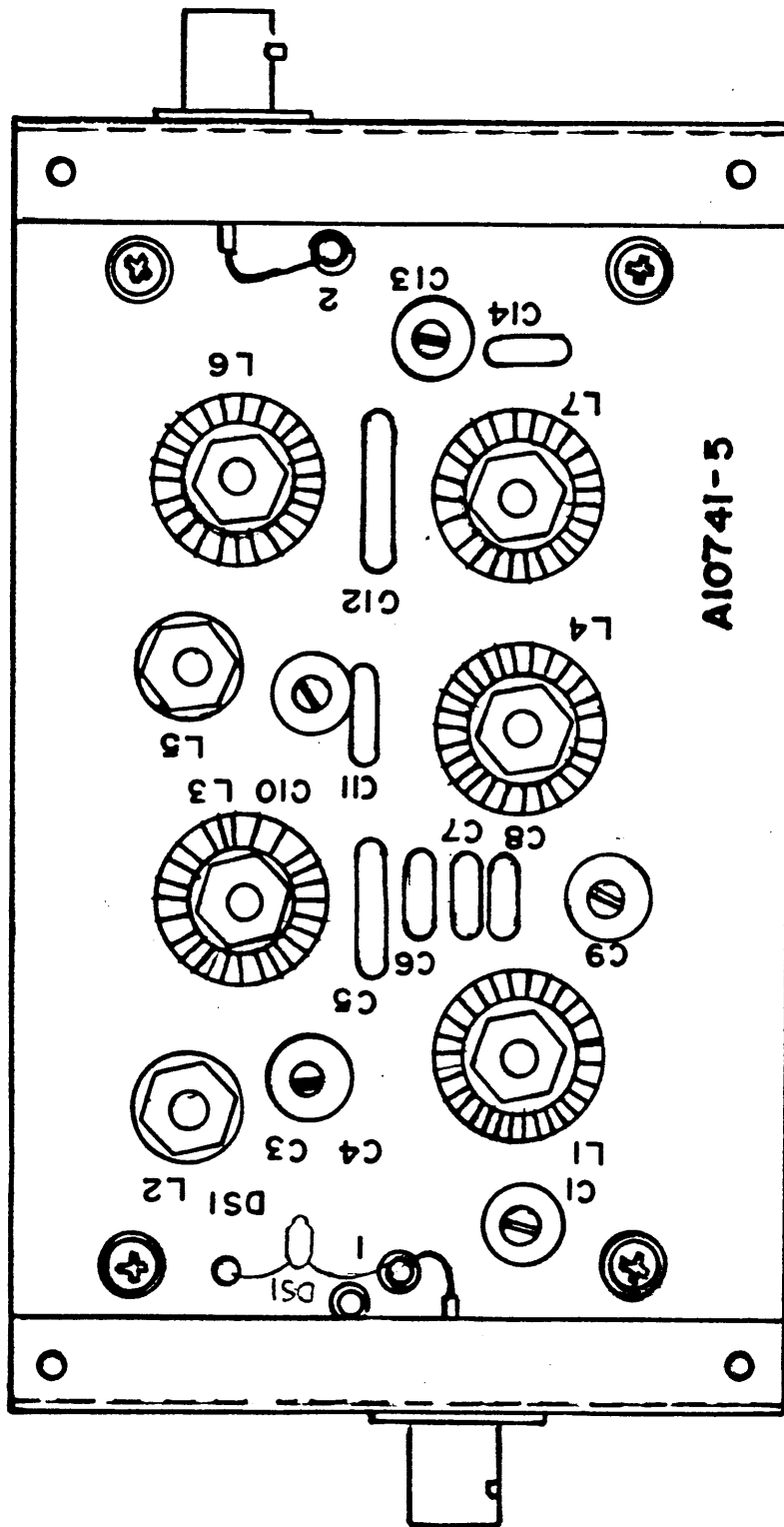

Figure 5-3

Bandpass Filter (FX10018-1) Assembly 1A2 Cover Removed

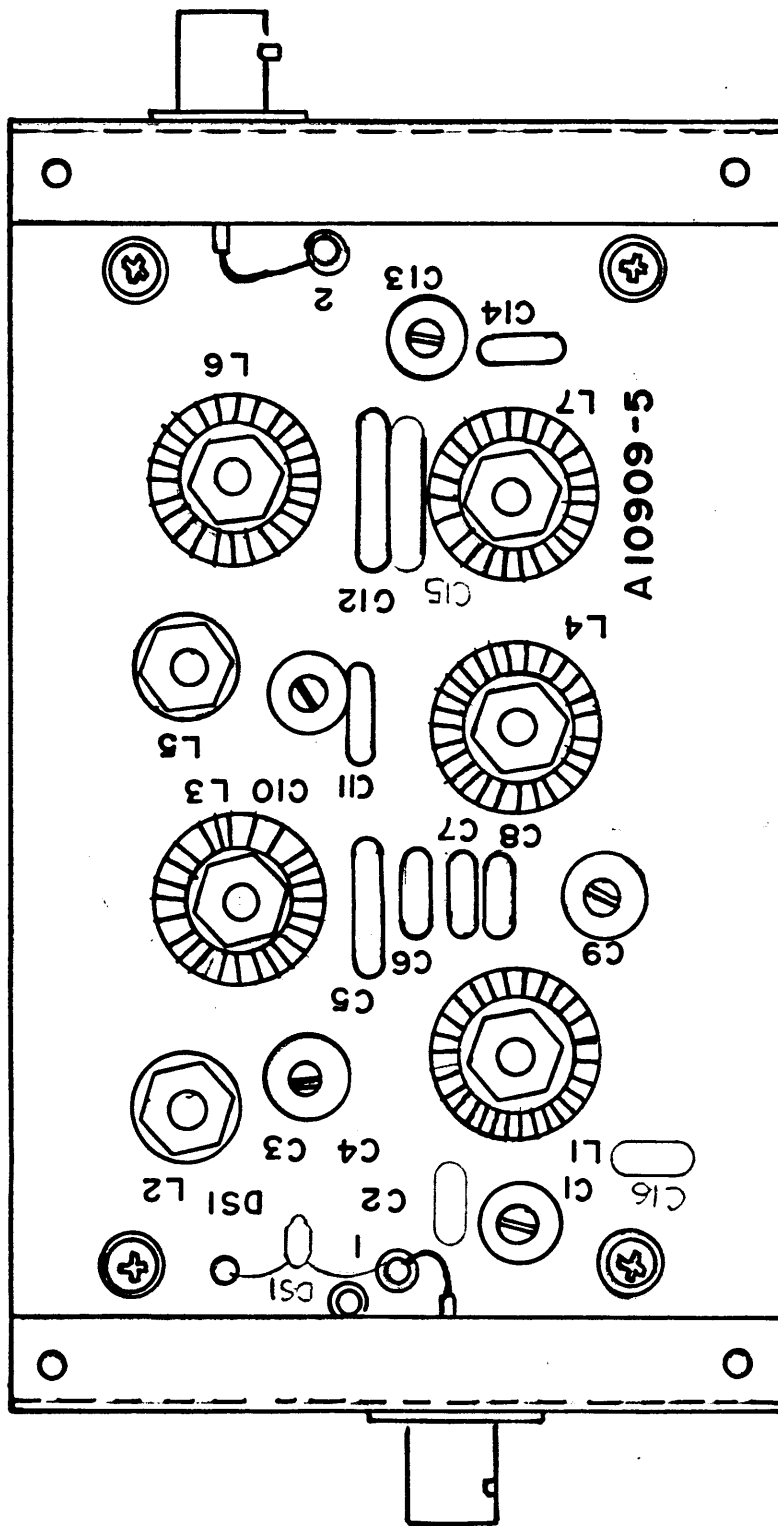

Figure 5-4

Bandpass Filter (FX10034) Assembly 1A2 Cover Removed

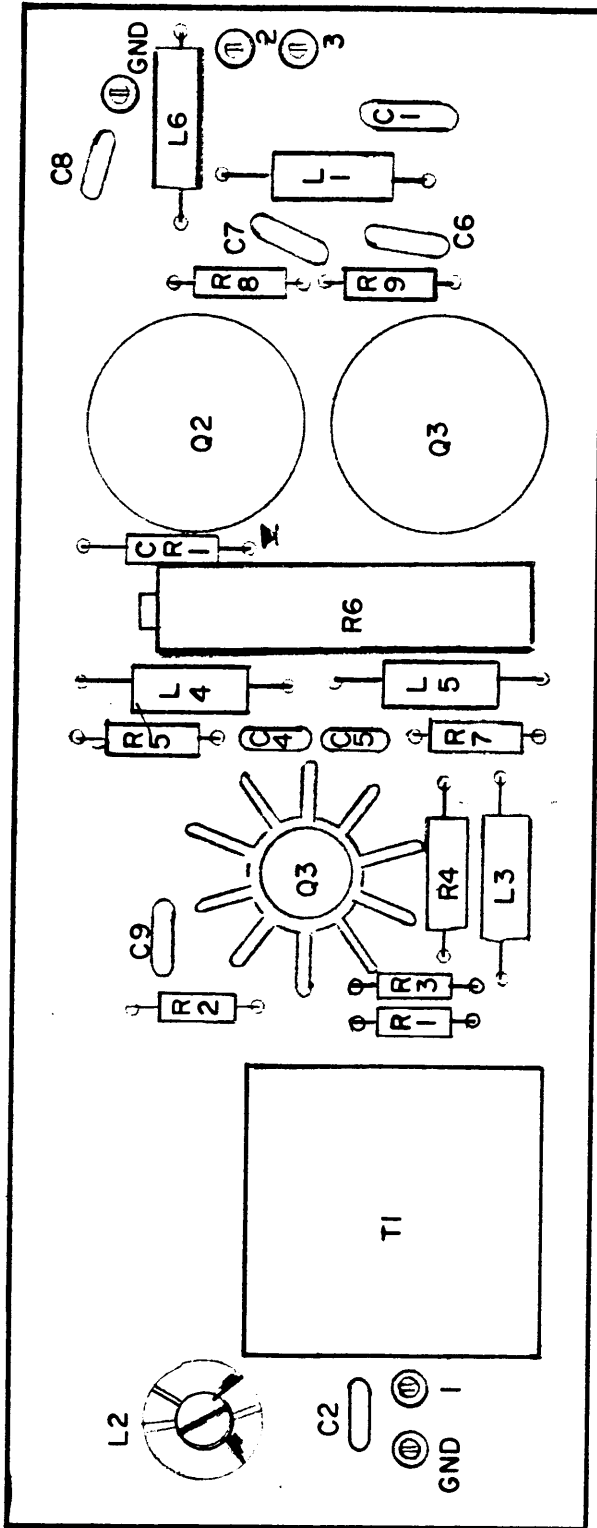

Figure 5-5

Preamplifier Assembly 1A3

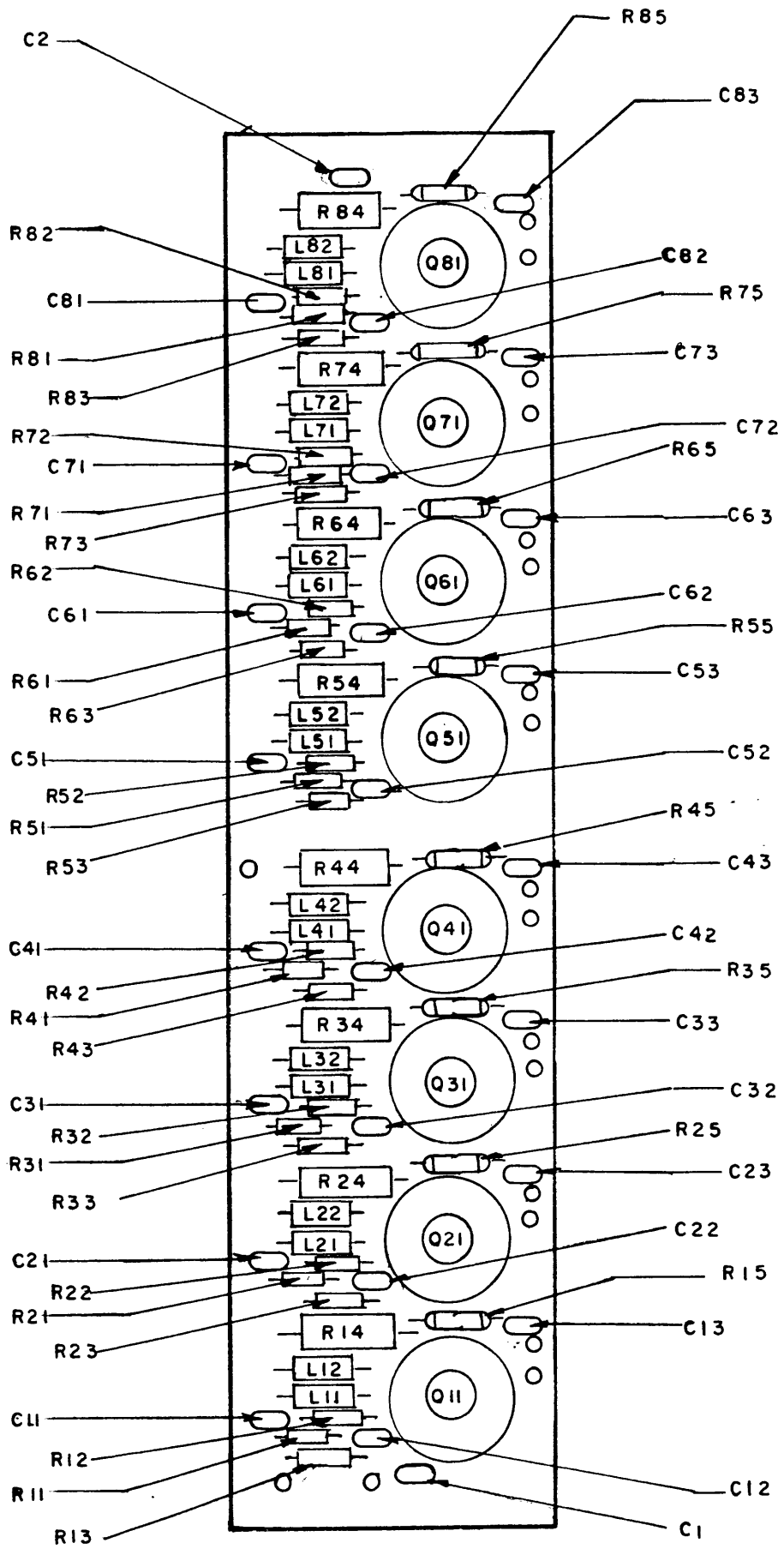

Figure 5-6
8 Output Assembly 1A4

SECTION 6

PARTS LIST

6-1. INTRODUCTION

(1) Reference symbols have been assigned to identify all electrical parts. These symbols are marked on the equipment adjacent to the parts that they identify and are included on all drawings, diagrams and part lists. The letters of a reference symbol indicate the generic group of the part, such as capacitor, resistor transistor etc. The numeral differentiates between parts of the same generic group. Sockets associated with any particular plug-in device, such as a transistor or fuse, are identified by a reference symbol which incorporates the symbol used for that device as well as a prefix symbol.

(2) Prefix symbols have also been assigned to each separate printed circuit board assembly (1A1, 1A2 etc.) to avoid confusion of identifying similar components in a different circuit.

(3) To expedite delivery when ordering replacement parts, specify the TMC part number and the name and model number of the equipment.

6-2. NOTE

(1) RF Cable Assembly

(a) The RF cable assembly is a coaxial cable having a male connector. The length of this cable is determined on final testing of the unit, and may vary between units. Its purpose is to compensate for any phase difference between an individual unit and the master standard.

AMC-8A
MAIN CHASSIS, FRONT & REAR PANELS

REF DESIGNATION	DESCRIPTION	TMC PART NUMBER
A1	VOLTAGE REGULATOR	A10746-5
A2	PREAMPLIFIER, 75 ohms	A10735-5
A2	PREAMPLIFIER, 50 ohms	A10735-6
A3	OUTPUT MODULE: 8 outputs, 75 ohms	A10714-5
A3	OUTPUT MODULE: 8 outputs, 50 ohms	A10714-6
A4	FILTER: BANDPASS, 75 ohms	FX10018
A4	FILTER: BANDPASS, 50 ohms	FX10034
W1	CABLE: RF, coaxial with connectors	CA10530 or CA10662
* C1	CAPACITOR: Electrolytic, 2800 uF	CE112-15
DS1	LAMP: Neon	B1100-51
F1, F2	FUSE: slo-blo, 0.5 amp (115 Vac operation only)	FU102-.5
F1, F2	FUSE: slo-blo, 0.25 amp (230 Vac operation only)	FU102-25
FL1	FILTER: RF, line	A5780
J1 to J9	CONNECTOR: BNC, receptable	UG625B/U
J10	CONNECTOR: Receptable, male	MS3102A-14S-7P
R1	RESISTOR, FXD	RW111-3
S1	SWITCH: Toggle	ST22K
* T1, T2	TRANSFORMER: Power	A5782
TB1	TERMINAL BOARD	TM102-2
Q1	TRANSISTOR	2N3055
Z1	DIODE BRIDGE NETWORK	NW10005

* Some units may use TF10060 (T1) in place of Assembly A5782 (T1,T2) some units may use CE44C222G in place of CE112-5.

A1, REGULATOR ASSEMBLY
A10746-5

REF. DESIGNATION	DESCRIPTION	TMC PART NUMBER
C1, C6	CAPACITOR: Fixed, ceramic, 0.1 uF	CC10015-X5V104M
C2	CAPACITOR: Fixed, tantalum, 6.8 uF	CSR13G685ML
C3, C5	CAPACITOR: Fixed, tantalum, 0.47 uF	CSR13G474ML
C4	CAPACITOR: Fixed, ceramic, 0.01 uF	CC10017-X5V103M
CR1	DIODE: Zener	IN758
CR2,	DIODE	IN914B
R1	RESISTOR: Fixed, composition, 47K, $\frac{1}{2}$ W, 5%	RC20GF473J
R2	RESISTOR: Fixed, composition, 68K, $\frac{1}{2}$ W, 5%	RC20GF683J
R3	RESISTOR: Fixed, composition, 15 ohms, $\frac{1}{2}$ W, 5%	RC20GF150J
R4	RESISTOR: Fixed, composition, 560 ohms, $\frac{1}{2}$ W, 5%	RC20GF561J
R5	RESISTOR: Fixed, composition, 1.2K, $\frac{1}{2}$ W, 5%	RC20GF122J
R6	RESISTOR: Fixed, composition, 2.9K, $\frac{1}{2}$ W, 5%	RC20GF392J
R7	RESISTOR: Variable, composition, 1K, linear curve, $\frac{1}{2}$ W	RV111U102A
R8	RESISTOR: Fixed, composition, $\frac{1}{2}$ W, 6.8K, 5%	RC20GF682J
Q1	TRANSISTOR: NPN, silicon	TX10001
Q2	TRANSISTOR: PNP, silicon	2N5086

PREAMPLIFIER ASSEMBLY
A10735-5, A10735-6

REF. DESIGNATION	DESCRIPTION	TMC PART NUMBER
C1, C6, C7	CAPACITOR: Fixed, ceramic 0.1 uF	CC10015-X5V104M
C2	CAPACITOR: Fixed, mica 47 pF, 2% (used only in A10735-5)	CM104ED470G03
C3, C4, C5, C8, C9	CAPACITOR: Fixed, ceramic .01 uF	CC10017-X5V103M
CR1	DIODE	1N914B
* R1	RESISTOR: Fixed, film 910 ohms, ½W, 2% (A10735-5)	RL07S911G
R1	RESISTOR: Fixed, film, 510 ohms ½W, 2% (A10735-6)	RL07S511G
R2	RESISTOR: Fixed, film 8.2 K, ½W, 2%	RL07S822G
R3	RESISTOR: Fixed, film 3K, ½W, 2%	RL07S302G
R4	RESISTOR: Fixed, comp, 330 ohms, ½W, 5%	RC20GF331J
R5, R7	RESISTOR: Fixed, film 2K, ½W, 2%	RL07S202G
R6	RESISTOR: Variable, 500 ohms	RV10009-501AP
R8, R9	RESISTOR: Fixed, comp, 7.5 ohms, ½W, 5%	RC07GF7R5J
L1	INDUCTOR: RF coil, 33 uH	CL275-330
L2	INDUCTOR: RF coil, 0.33 uH (used only in A10735-5)	CL10044
L3, L4, L5	INDUCTOR: RF coil, 220 uH	CL275-221
T1	TRANSFORMER: RF	TR10005
L6 Q1, Q2	INDUCTOR, RF COIL 1.5UH TRANSISTOR	CL500 2N5160
Q3	TRANSISTOR	2N3866

8 OUTPUT ASSEMBLY
A10714 - 5 and -6

REF. DESIGNATION	DESCRIPTION	TMC PART NUMBER
C1, C2, C12, C13, C22, C23, C32, C33, C42, C43, C52, C53, C62, C63, C72, C73, C82, C83	CAPACITOR: Fixed, mica 0.1 uF	CC10015-X5V104M
C11, C21, C31, C41, C51, C61, C71, C81	CAPACITOR: Fixed, mica, 0.01 uF	CC10017-X5V103M
L11, L21, L31, L41, L51, L61, L71, L81	INDUCTOR: RF coil, 33 uH	CL275-330
L12, L22, L32, L42, L52, L62, L72, L82	INDUCTOR: RF coil, 220 uH	CL275-221
R11, R21, R31, R41, R51, R61, R71, R81	RESISTOR: Fixed, composition 100 ohms, $\frac{1}{2}$ W, 5%	RC07GF101J
R12, R22, R32, R42, R52, R62, R72, R82	RESISTOR: Fixed, composition 4.3 K, $\frac{1}{2}$ W, 5%	RC07GF432J
R13, R23, R33, R43, R53, R63, R73, R83	RESISTOR: Fixed, composition 3.3 K, $\frac{1}{2}$ W, 5%	RC07GF332J
R14, R24, R34, R44, R54, R64, R74, R84	RESISTOR: Fixed, composition 220 ohms, 1W, 5%	RC32GF221J
*R15, R25, R35, R45, R55, R65, R75, R85	RESISTOR: Fixed, film 71.5 ohms, $\frac{1}{2}$ W, 1%	RNGOD71R5F
Q11, Q21, Q31, Q41, Q51, Q61, Q71, Q81	TRANSISTOR	2N3866

*The value of R15 and R85 for -6 is 51.3 ohms

BANDPASS FILTER FX10034* ASSEMBLY 1A2

REF DESIGNATION	DESCRIPTION	TMC PART NUMBER
1A2C1	CAPACITOR	CV112-6
1A2C2	CAPACITOR	CM04ED820G03
1A2C3	SAME AS 1A2C1	
1A2C4	CAPACITOR	CM04CD050D03
1A2C5	CAPACITOR	CM06FD132F03
1A2C6	SAME AS 1A2C2	
1A2C7	CAPACITOR	CM04FD101J03
1A2C8	SAME AS 1A2C4	
1A2C9	SAME AS 1A2C1	
1A2C10	SAME AS 1A2C1	
1A2C11	CAPACITOR	CM04ED270G03
1A2C12	CAPACITOR	CM06FD132F03
1A2C13	SAME AS 1A2C1	
1A2C14	CAPACITOR	CM04ED680G03
1A2DS1	LAMP	BI10005
1A2J1	CONNECTOR	UG290A/U
1A2J2	SAME AS 1A2J1	
1A2L1	INDUCTOR	CL10050-2
1A2L2	INDUCTOR	CL10051-1
1A2L3	INDUCTOR	CL10050-5
1A2L4	INDUCTOR	CL10050-1
1A2L5	INDUCTOR	CL10051-2
1A2L6	INDUCTOR	CL10050-4
1A2L7	INDUCTOR	CL10050-3

* See figure 7-3 for FX10018-1 (75 Ω)

SECTION 7
SCHEMATIC DIAGRAMS

230 VAC	FI02,25	0.25 AMP
115 VAC	FI02,50	0.50 AMP
POWER INPUT	FI/F2 P/N	FI/F2 RATING

IJ10
POWER INPUT
115 VAC
60 Hz

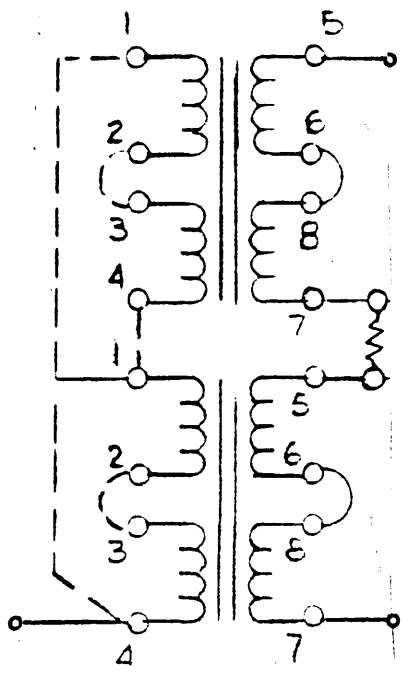

2. 230V OPERATION FOR A5782

3.

AMC B, 75Ω	A10735-5	A10714-5	FX10018-1
AMC B, 50Ω	A10735-6	A10714-6	FX10034
UNT	A2 P/N	A3 P/N	A4 P/N

4. SOME UNITS MAY USE TF10060 (T1) IN PLACE OF ASSEMBLY A5782(T1,T2)

5. 230V OPERATION FOR TF10060

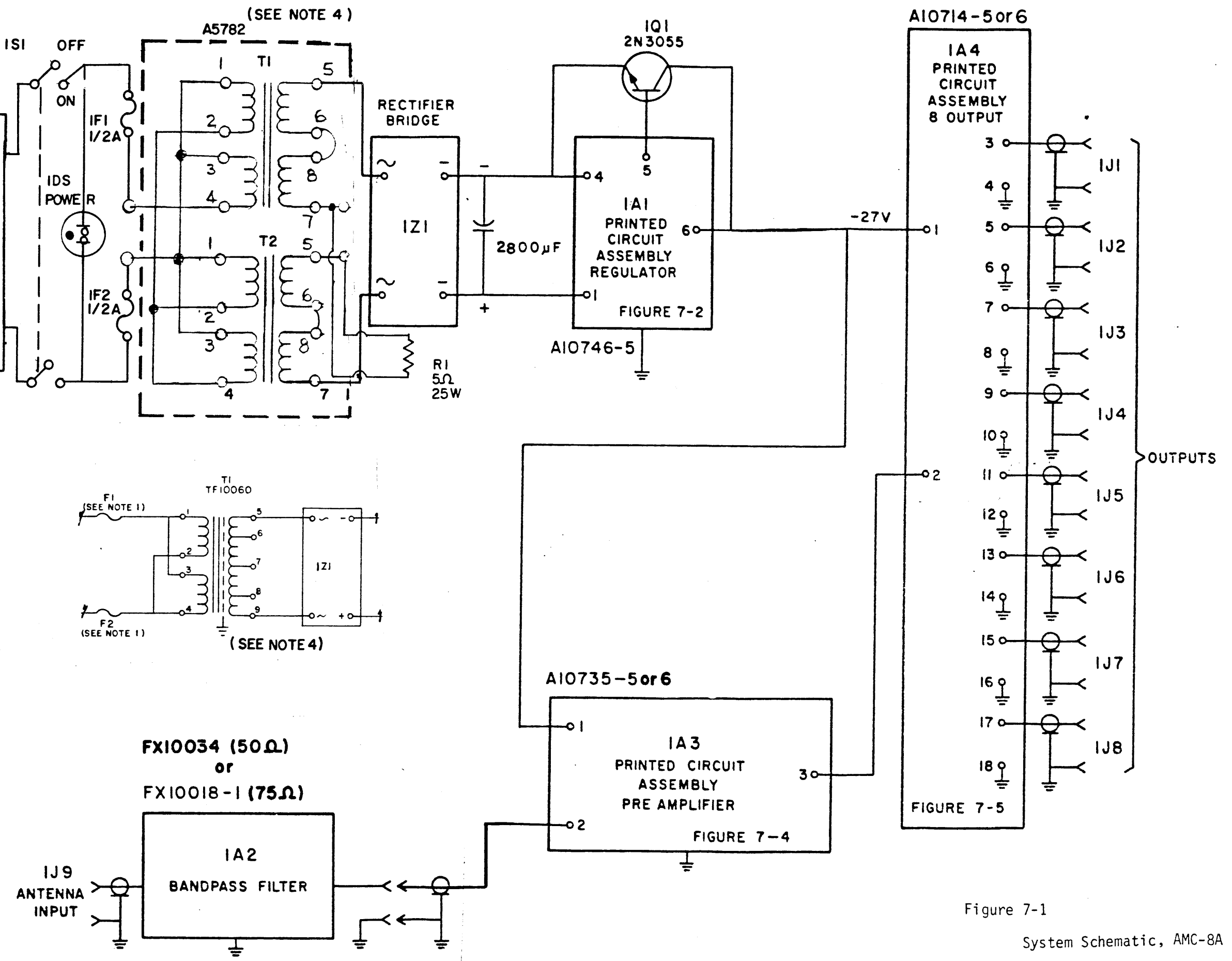

Figure 7-1
System Schematic, AMC-8A

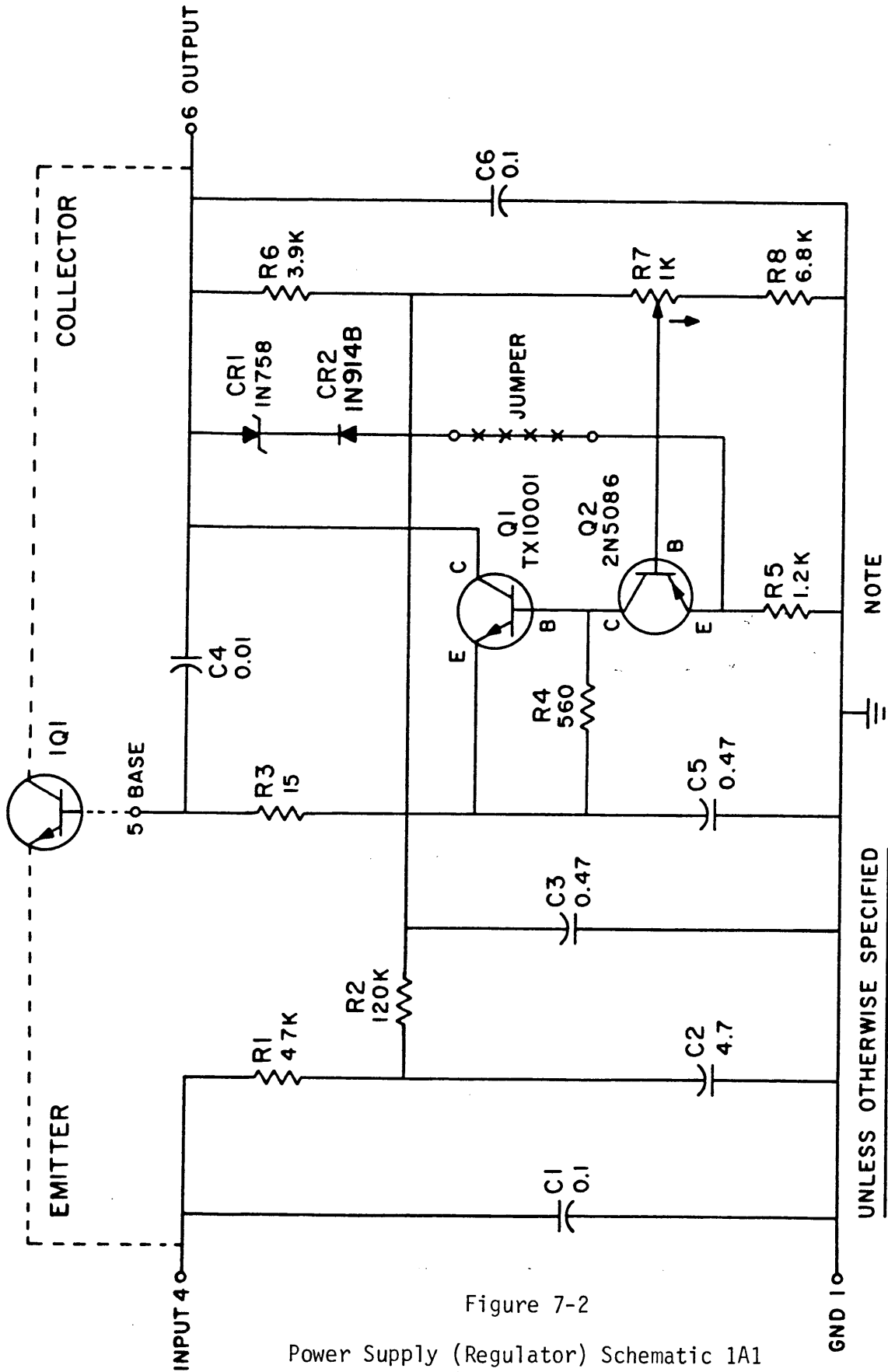
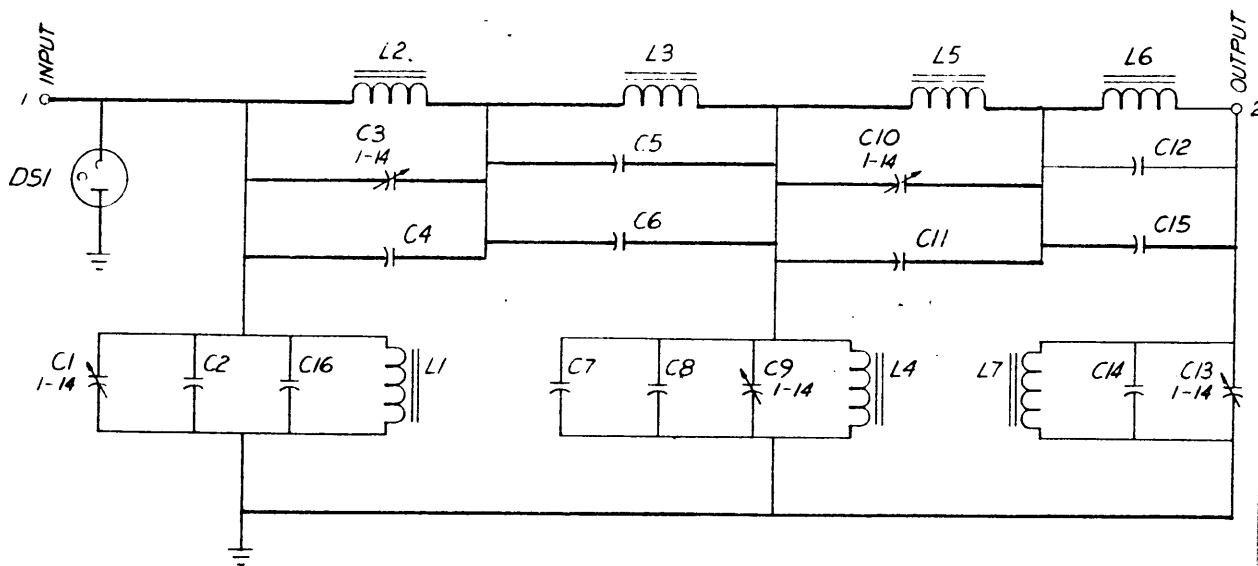

Figure 7-2
Power Supply (Regulator) Schematic 1A1



C16	DSI	L7	
LAST COMP USED		MISSING COMP	

FX10018-1	75 Ω	5.61	.448	29.2	3.58	.306	9.52	7.5	56	5	820	56	91	5	27	1300	43		
FX10034	50 Ω	3.74	.299	19.45	2.39	.204	6.35	5	82	12	1300	12	100	47	43	1200	68	750	5
TYPE	IMPEDENCE	L1	L2	L3	L4	L5	L6	L7	C2	C4	C5	C6	C7	C8	C11	C12	C14	C15	C16

BANDPASS FILTER

UNLESS OTHERWISE SPECIFIED

ALL CAPACITANCE IN pF
ALL INDUCTANCE IN μH

Figure 7-3

Bandpass Filter Schematic 1A2

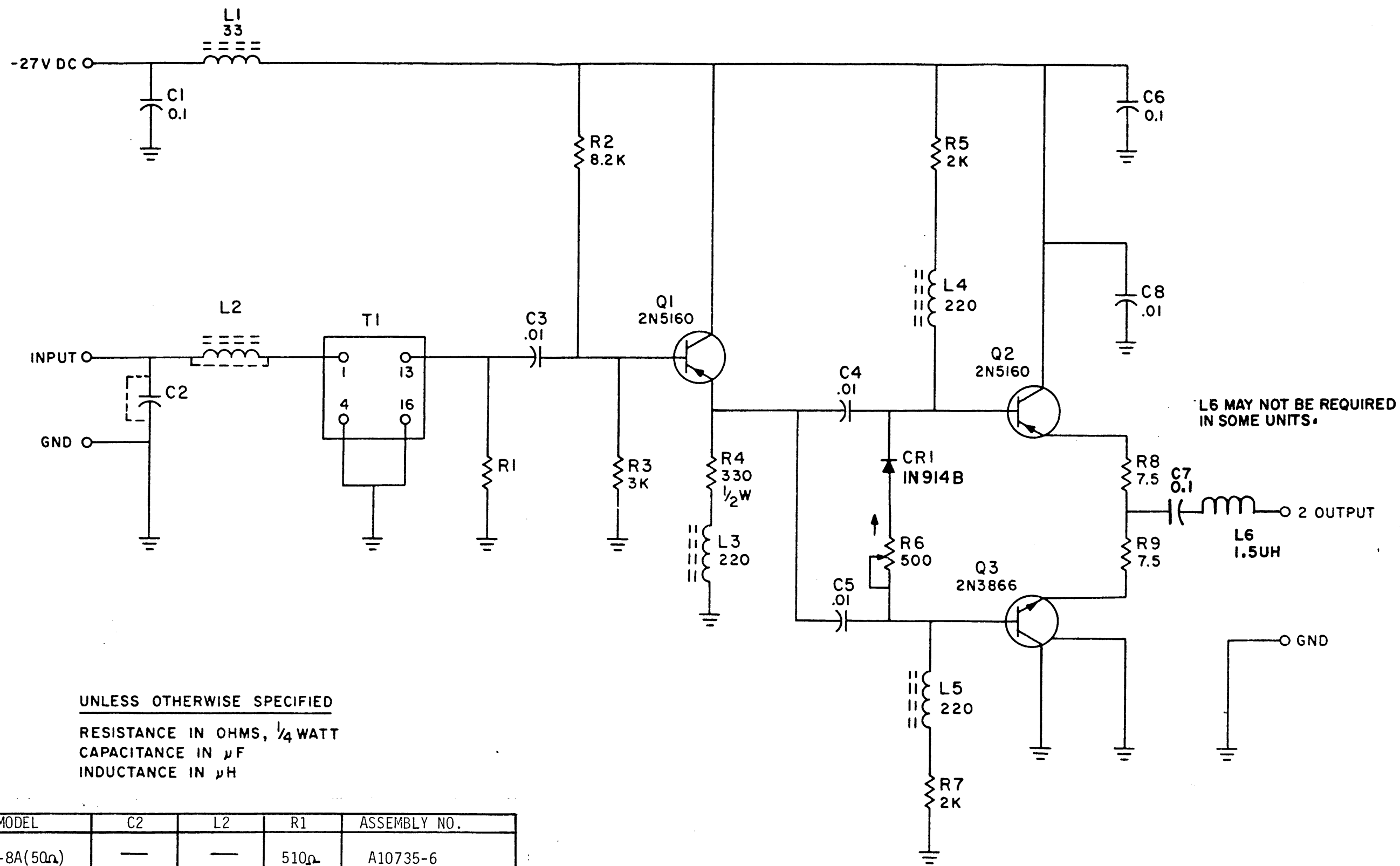
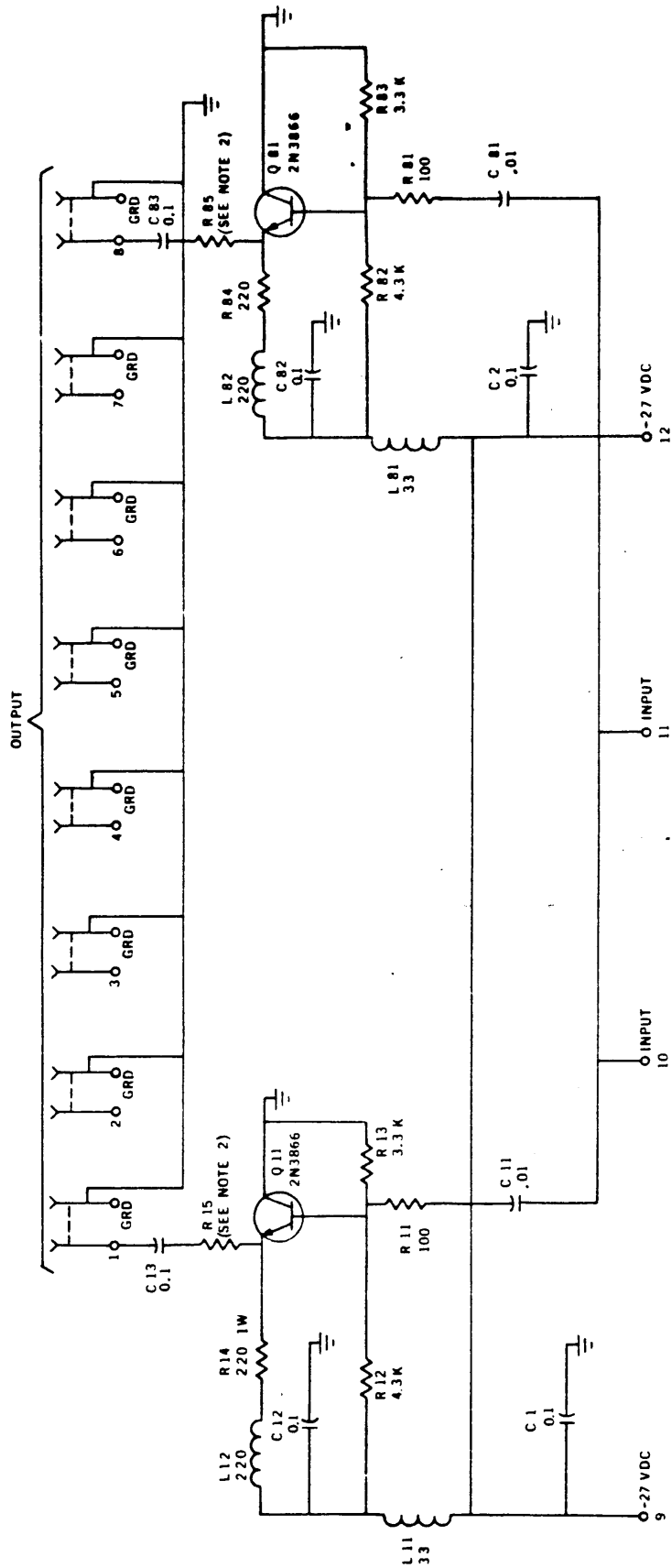

Figure 7-4

Preamplifier Schematic 1A3



MODEL	R 15		R 85		ASSEMBLY NO
	50 Ω	75 Ω	50 Ω	75 Ω	75 Ω
AMC 8	52.3	71.5	52.3	71.5	A-10714-6
					A-10714-5

2

1 INDUCTANCE IN MICROHENRIES
CAPACITANCE IN MICROFARADS
RESISTANCE IN OHMS
UNLESS OTHERWISE STATED:

NOTES:

Figure 7-5
8 Output Schematic 1A4

REF SYMBOL	DESCRIPTION	TMC PART NUMBER
C1,C2 C3,C4	CAPACITOR: Fixed	CC100-32
L1,L2	COIL: Fixed	CL105-1

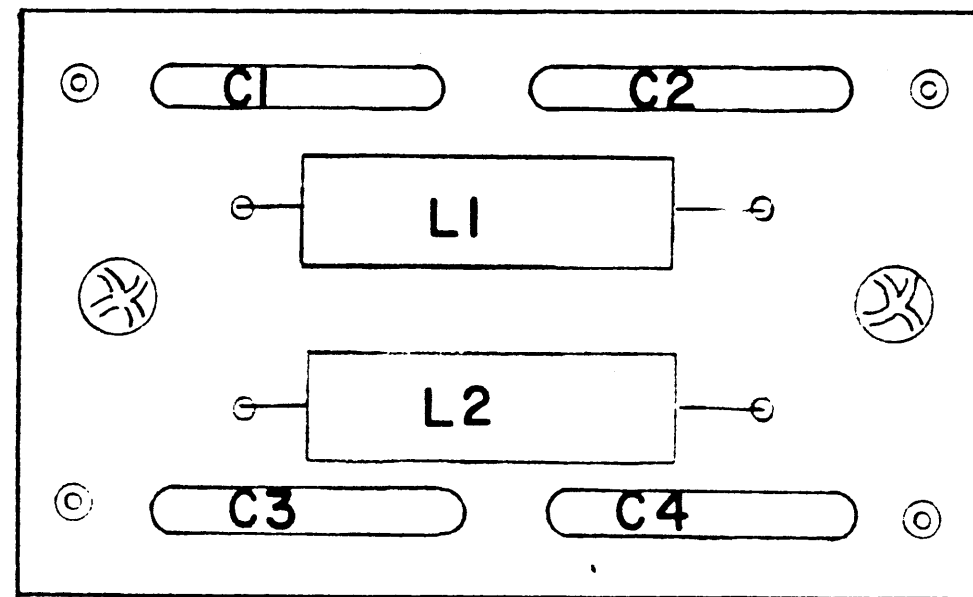

A5780
(FLI)

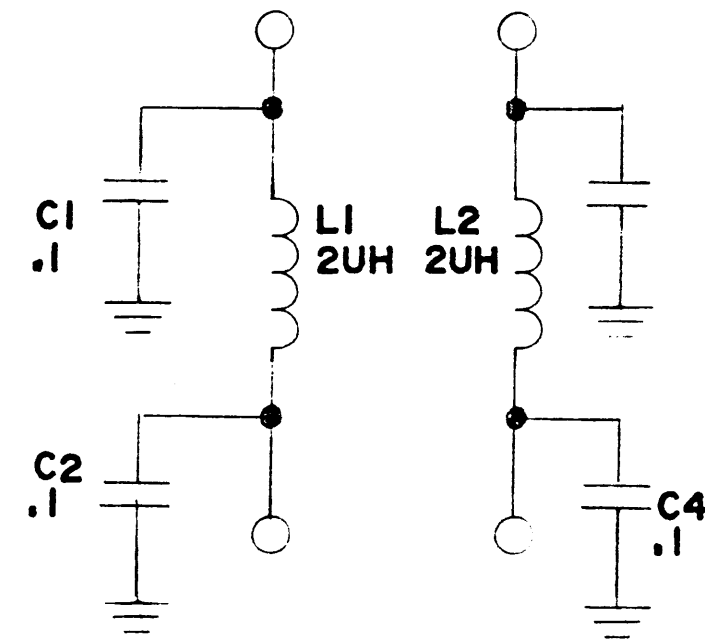

Figure 7-6
AC Filter Diagram

Part Number	Description	Used On	Qty	Symbol Number
PC819	PRINTED CIR. BD.	A5782	1	
TF447	TRANS. POWER	A5782	2	T1, T2

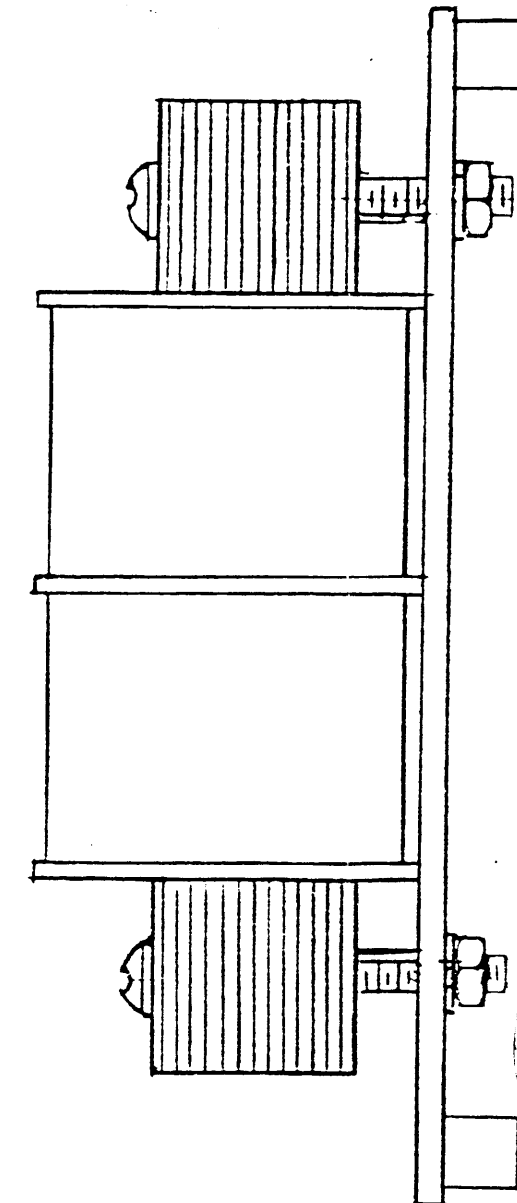
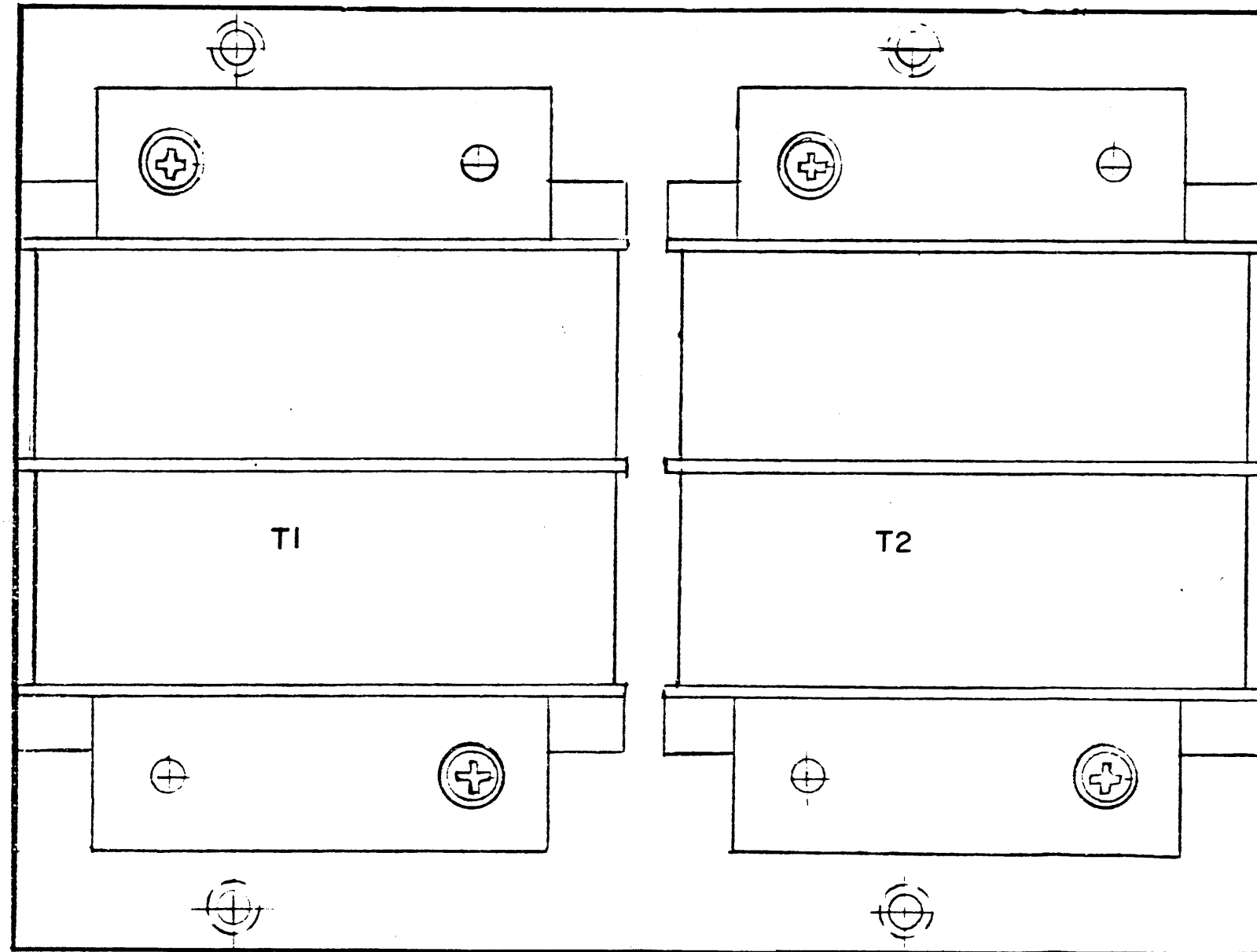

Figure 7-7

TRANSFORMER POWER ASSY.
A5782