

S. O. FILE COPY

DO NOT RELEASE

★
UNCLASSIFIED

TECHNICAL MANUAL
for
DUAL DIVERSITY RECEIVER
MODEL DDR-7B
—
SYSTEM



THE TECHNICAL MATERIEL CORPORATION
MAMARONECK, N. Y. OTTAWA, ONTARIO

★

TECHNICAL MANUAL
for
DUAL DIVERSITY RECEIVER
MODEL DDR-7B

SYSTEM

THE TECHNICAL MATERIEL CORPORATION

MAMARONECK, N.Y.
IN-331-S

OTTAWA, ONTARIO
ISSUE DATE 20 APRIL 1964

FOREWORD

TMC's Dual Diversity Receiver, Model DDR-7B, consists of 13 major components as follows:

<u>Qty</u>	<u>Component</u>
2	GPR-92 Communications Receiver
1	NRC* Type 173, Model 2 Variable Master Oscillator
1	NRC* Power Supply for Type 173 Oscillator
1	NRC* Type 108, Model 2 Master Crystal Oscillator-Multiplier
2	SBS-I-1** Sideband Selector
2	AFC-2A** Automatic Frequency Control
1	HSP-3 Audio Switch Panel
1	DCP-2 Power Control Panel
1	LSP-6 Speaker Panel
1	Bud Radio Model B-25 Blower

These 13 basic units are also included in various TMC receiver systems as well as in the DDR-7B. To satisfy this condition most practically, individual manuals on each unit are written, then combined, as required to cover any receiver system. The DDR-7B manual is made up of individual manuals as described in Table of Contents, Model DDR-7B.

* NRC = Northern Radio Company

** Part of SBC-I-1A Sideband Converter

TABLE OF CONTENTS
DUAL DIVERSITY RECEIVER
MODEL DDR-7B

<u>Part</u>	<u>Title</u>
1	Technical Manual for Dual Diversity Receiver, Model DDR-7B -- System
2	Technical Manual for Communications Receiver, Model GPR-92
3	Northern Radio Co. Instruction Book, Variable Master Oscillator, Type 173
4	Northern Radio Co. Instruction Book, Master Crystal Oscillator-Multiplier Type 108
5	Technical Manual for Sideband Converter, Model SBC-1 and SBC-2
6	Technical Manual for Sideband Selector, Models SBS-1 and SBS-2
7	Technical Manual for Automatic Frequency Control, Models AFC-2A and AFC-3
8	Technical Manual for Dual Diversity Receiver, Model DDR-7B -- Appendix (includes description of LSP-6 Speaker Panel, HSP-3 Audio Switch Panel, DCP-2 Power Control Panel, RAK-47B Rack and Bud Radio Model B-25 Blower)

TABLE OR CONTENTS

DDR-7B SYSTEM

<u>Paragraph</u>		<u>Page</u>
<u>SECTION 1 - GENERAL DESCRIPTION</u>		
1-1	Function- - - - -	1-1
	<u>a.</u> General- - - - -	1-1
	<u>b.</u> Components- - - - -	1-3
1-2	Physical Description - - - - -	1-3
<u>SECTION 2 - INSTALLATION</u>		
2-1	Introduction- - - - -	2-1
2-2	Initial Inspection- - - - -	2-1
2-3	Rack Installation- - - - -	2-1
2-4	Line Voltage Modification - - - - -	2-1
	<u>a.</u> General- - - - -	2-1
2-5	Assembly of Receiver- - - - -	2-2
2-6	Connection of External Equipment- - - - -	2-2
	<u>a.</u> Introduction- - - - -	2-2
	<u>b.</u> Antenna Inputs- - - - -	2-2
	<u>c.</u> Audio Outputs- - - - -	2-2
	<u>d.</u> Line Voltage Input- - - - -	2-2
<u>SECTION 3 - OPERATOR'S SECTION</u>		
3-1	Introduction- - - - -	3-1
	<u>a.</u> General- - - - -	3-1
	<u>b.</u> Modes of Reception- - - - -	3-1
	<u>c.</u> Functions of Components- - - - -	3-2
	<u>d.</u> Functions of Controls- - - - -	3-4
3-2	Tuning Procedures- - - - -	3-5

TABLE OF CONTENTS (con't)

DDR-7B SYSTEM

Paragraph

Page

SECTION 3 - OPERATOR'S SECTION (con't)

<u>a.</u> Tuning Tables- - - - -	3-5
<u>b.</u> Diversity Tuning- - - - -	3-6
<u>c.</u> NRC Oscillators- - - - -	3-7
<u>d.</u> Bandspread- - - - -	3-11
<u>e.</u> Slot Tuning Method- - - - -	3-12
<u>f.</u> Slot Tuning Vs. Reception Mode- - - - -	3-15
<u>g.</u> AGC Systems - - - - -	3-18

LIST OF ILLUSTRATIONS

DDR-7B SYSTEM

<u>Figure</u>		<u>Page</u>
<u>SECTION 1 GENERAL DESCRIPTION</u>		
1-1	Dual Diversity Receiver, Model DDR-7B- - - -	v
<u>SECTION 2 INSTALLATION</u>		
2-1	Slide Mounting Details- - - - -	2-4
2-2	Connection Diagram, External Equipment to DDR-7B- - - - -	2-5
<u>SECTION 3 OPERATOR'S SECTION</u>		
3-1	Functional Block Diagram, DDR-7B- - - - -	3-45
3-2	FSK Converter Center Frequency Vs. DDR-7B Shift Capabilities- - - - -	3-46
3-3	Slot Tuning Diagrams, DDR-7B- - - - -	3-47

LIST OF TABLES

DDR-7B SYSTEM

<u>Table</u>		<u>Page</u>
<u>SECTION 1 - GENERAL DESCRIPTION</u>		
1-1	Electrical Characteristics, DDR-7B- - -	1-4
<u>SECTION 3 - OPERATOR'S SECTION</u>		
3-1	Tune-up Procedure for CW (Using GPR-92 Alone, Non-Diversity)- - - - -	3-21
3-2	Tune-up Procedure for CW (Using GPR-92 and NRC Oscillators Non-Diversity)- - -	3-22
3-3	Tune-up Procedure for MCW (Using GPR-92 Alone, Non-Diversity)- - - - -	3-25
3-4	Tune-up Procedure for MCW (Using GPR-92, SBS-I-1 and AFC-2A, Diversity or Non-Diversity)- - - - -	3-25A
3-5	Tune-up Procedure for SSB with Partial Carrier (Using GPR-92, SBS-I-1 and AFC-2A, Diversity or Non-Diversity)- - - - -	3-27
3-6	Tune-up Procedure for SSB with Fully Suppressed Carrier (Using GPR-92, NRC Oscillators and SBS-I-1, Diversity or Non-Diversity)- - - - -	3-29
3-7	Tune-up Procedure for ISB with Partial Carrier (Using GPR-92, SBS-I-1 and AFC-2A, Diversity or Non-Diversity)- - - - -	3-33
3-8	Tune-up Procedure for ISB with Fully Suppressed Carrier (Using GPR-92, NRC Oscillators and SBS-I-1, Diversity or Non-Diversity)- - - - -	3-36
3-9	Tune-up Procedure for AM (SSB Reception, Using GPR-92, SBS-I-1 and AFC-2A, Diversity or Non-Diversity)- - - - -	3-39
3-10	Tune-up Procedure for FSK (Using GPR-92, NRC Oscillators and SBS-I-1, Diversity or Non-Diversity)- - - - -	3-41

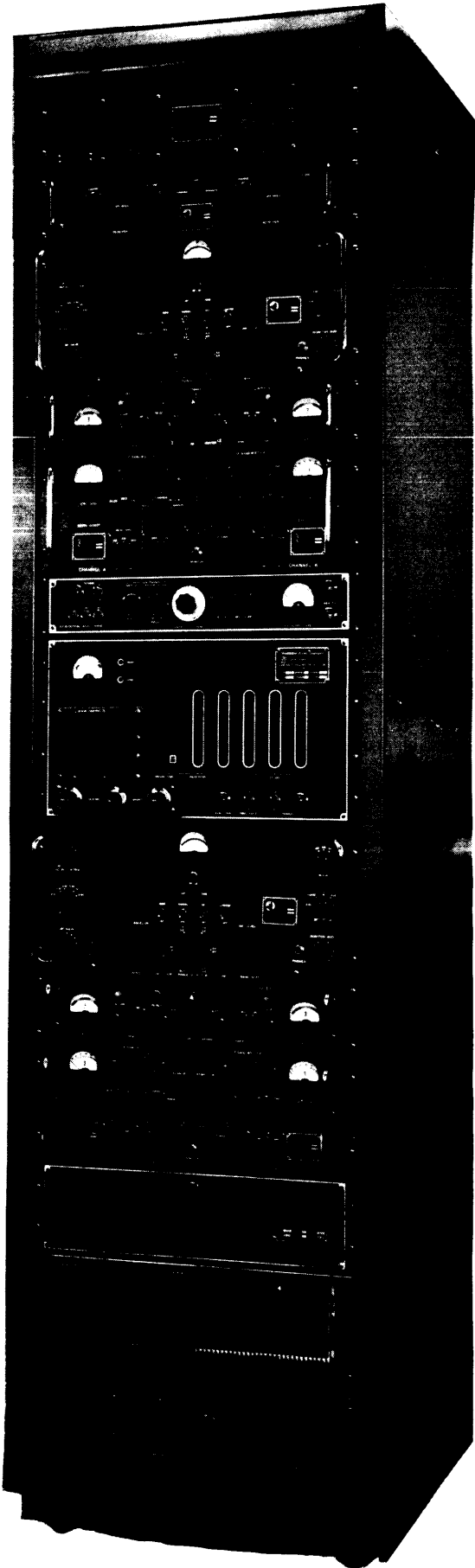

FIGURE 1-1. Dual Diversity Receiver, Model DDR-7B

SECTION 1

GENERAL DESCRIPTION

1-1. FUNCTION

a. GENERAL - Model DDR-7B Dual Diversity Receiver (figure 1-1) is two separate receiver systems. Each system receives CW, MCW, AM, SSB, ISB and FSK transmission and the two systems may be operated singly or in diversity. The input frequency range is 0.54 - to 32.3-mc in six bands. The receiver is continuously tunable throughout the range and requires no plug-in units. Two selectable sideband widths enable reception of 3.5-kc or 6-kc single sidebands or two 3.5-kc or 6-kc independent sidebands. In 6-kc ISB (independent sideband) reception, diversity operation renders two separate 6-kc width audio outputs; each output can be further divided into 2 discrete voice channels (making a total of 4 discrete channels) by an external demultiplexer similar to TMC Model RMX-2 in associated receiving equipment, if desired.

Reception of an AM signal is greatly improved by utilizing the SSB tuning facilities inherent in the DDR-7B. Effectively the intelligence is derived from one sideband alone, discarding the carrier and the other sideband and thus filtering out many adjacent noise frequencies.

An automatic frequency control locks onto the received carrier and is available for all sideband signals containing a carrier suppressed down to as much as 30 db below PEP (peak envelope power). Compensation for a combined transmitter/receiver frequency drift corrects the product detector for sideband signals to produce audio to within 1 cps of the original transmitted tone. In the event of temporary carrier fade, a memory circuit keeps the product detector oscillator stable until the carrier returns.

Sideband reception of AM and MCW also enables the use of the automatic frequency control feature, eliminating the need for constant monitoring due to frequency drift.

In FSK (frequency shift keying) reception the audio output mark and space frequencies may be adjusted to any frequencies required to operate a frequency shift converter.

In diversity operation, common HFO and IFO sources are used for the two receiver systems. NRC Type 173 Oscillator and Type 108 Oscillator-Multiplier provide the common sources and are tuned to provide the proper HFO frequency for the first r-f mixer stage.

In non-diversity operation, when a receiver system is used separately, and when there is a small amount of carrier, the highly stable Model 2 Oscillator is not necessary, where it is possible to use the automatic frequency control feature. In this case, tuning the r-f section of the receiver automatically selects the proper internal HFO frequency and steps necessary for calculating HFO and tuning the NRC oscillators are eliminated. For tuning in sideband signals with no carrier, the NRC oscillators may or may not be required, depending upon transmitting conditions. Using the receiver systems separately also can provide a maximum of 8 voice channels that may be simultaneously received from two ISB transmissions.

A variety of AGC systems are available with response speeds for all modes of transmission.

Each receiver system has two audio output channels; each channel is further divided into high-and low- level power outputs. The high- level outputs drive the system speakers. The low level outputs are suitable for driving any 600-ohm impedance loads requiring

up to 1-mw of input power. All outputs may be used simultaneously and are connected into the system by front-panel controls.

A single switch (AGC SEPARATE/COMBINED), on the front panel, switches the two receiver systems in and out of diversity.

b. COMPONENTS - Model GPR-92 Communications Receiver is used to tune in the signal in its r-f stage and convert it to the i-f stage. This receiver includes its own internal HFO and IFO. NRC Type 173 Variable Master Oscillator and Type 108 Master Crystal Oscillator-Multiplier serve as a highly stable HFO and IFO source when required in diversity operation. Model SBS-I-1 Sideband Selector is used to pick one or both sidebands out of the signal in the i-f stage and convert them to audio intelligence. Or it may be used to process the entire AM envelope in the conventional manner through a diode detector. Model AFC-2A Automatic Frequency Control is used in sideband reception with partial carrier to compensate for transmitted frequency drift. Model LSP-6 Speaker Panel contains the two 4-1/2-watt magnetic speakers, Model HSP-3 Audio Switch Panel is a switching panel for connecting SBS-I-1 audio outputs to the speakers and includes impedance matching transformers and dummy loads for the high level outputs and r-f chokes for the low-level outputs. Also included in the HSP-3 panel is the AGC switch for combining or separating the AGC feedbacks of the two systems for diversity or non-diversity operation, respectively.

1-2. PHYSICAL DESCRIPTION

The complete DDR-7B system is contained in a single 18-ga. 22 in. wide x 24-1/2 in. deep x 86-1/2 in. high steel rack equipped with drawer slides for all major components except the LSP-6 Speaker Panel, HSP-3 Audio Switch Panel, Bud Model B-25 Transaire Blower and DCP-2 Power Control Pan 1.

A full length servicing door on the back provides access to all inter-connecting cabling. The rack contains its own forced-air cooling system consisting of a squirrel-cage intake blower mounted in the lower portion of the front-panel. The intake aperture on the blower is equipped with a removable air filter accessible from the panel. The louvered exhaust aperture is located in the top part of the service door. The SBS-I-1 units also contain built-in blowers. When completely assembled, DDR-7B weighs 763 pounds. This standard rack and component finish, unless otherwise specified, is TMC RCAF blue-grey smooth enamel.

TABLE 1-1. ELECTRICAL CHARACTERISTICS, DDR-7B

Frequency range:	0.54-32.3 megacycles in six bands:	
	Band	Range (mc)
	1 - - - - -	0.54 - 1.4
	2 - - - - -	1.4 - 3.3
	3 - - - - -	3.3 - 5.6
	4 - - - - -	5.6 - 9.5
	5 - - - - -	9.5 - 17.5
	6 - - - - -	17.3 - 32.3
Types of Reception:	(a) AM, SSB, ISB (all with 3.5- or 6-kc sidebands) (b) CW, MCW and FSK* (c) All modes-diversity or single receiver	
Noise Factor and Sensitivity	6 db or better from 2-30mcs. A 1-microvolt input signal at 6.0 kc bandwidth will provide at least 15 db signal + noise to noise ratio.	
Bandpass width:	12-kc max (for ISB), 6-kc max (for SSB)	
Frequency stability: (0° - 50°C)	With NRC Type 173 Oscillator:	Better than 0.2 part per mil, + 2.5 cycles for any 12-hour period. Better than 1 part per mil, + 2.5 cycles for any 30 day period.

*With appropriate frequency shift converter

TABLE 1-1. ELECTRICAL CHARACTERISTICS, DDR-7B (Con't)

Frequency Stability (Cont):	With AFC-2A: See "Automatic Frequency Control" description following.
Automatic Frequency Control:	In sideband reception, with carrier suppressed to a maximum of 25 db, AFC compensates for a maximum drift rate of 10 cps/second over a maximum range of ± 750 cps in the receiver i-f. Audio output is maintained to within 1 cps error.
Audio output connections:	Per receiver system: <ul style="list-style-type: none"> - Two adjustable 0-1-mw, balanced or unbalanced, 600-ohm outputs, channel A and B, (terminal block). - Headset monitor jack at GPR-92. - Headset monitor jack at SBS-I-1 for channel A or B.
Image ratio:	Average, 80 db.
IF rejection:	Better than 80 db from 2 to 30mcs.
Antenna input connection:	Type BNC jack for a nominal 70-ohm unbalanced transmission line.
Carrier reinsertion (sideband reception):	<ul style="list-style-type: none"> a. AFC adjusted transmitted carrier (for carrier suppressed to a maximum of 25 db below PEP) b. Artificial crystal-controlled carrier (for carrier suppressed below 25 db)
Unwanted sideband rejection:	Undesired sidebands, removed more than 250 cps from the carrier, are attenuated at least 60 db below PEP.

TABLE 1-1. ELECTRICAL CHARACTERISTICS, DDR-7B (Cont)

Inband distortion:	45 db below PEP
Cross channel distortion:	60 db below PEP
Audio distortion:	45 db below PEP
Monitoring:	<ul style="list-style-type: none"> a. r-f stage level indicator in GPR-92 b. i-f stage, CARRIER LEVEL meter and CARRIER FADE light in AFC-2A c. i-f stage, CARRIER DRIFT meter and CARRIER DRIFT ALARM light in AFC-2A.
Power consumption:	Average: 1600 watts

SECTION 2

INSTALLATION

2-1 INTRODUCTION

Each DDR-7B Dual Diversity Receiver has been tested as a complete system before shipment. Upon shipment it is disassembled and packed into crates. It is only necessary to unpack and reassemble the equipment as outlined in the following paragraphs. Recalibration of the individual modular units is not necessary.

2-2 INITIAL INSPECTION

The complete DDR-7B will arrive in crates containing components as listed in table F in the Appendix section of this manual. Inspect each crate and its contents immediately for possible damage. Unpack the equipment carefully. Inspect all packing material for parts which may have been shipped as "loose items". With respect to damage to the equipment for which the carrier is liable, the Technical Materiel Corporation will assist in describing methods of repair and the furnishing of replacement parts.

2-3 RACK INSTALLATION

The DDR-7B rack measures 22 in. wide x 24-1/2 in. deep x 86-1/2 in. high. A clearance of about two feet at the rear of the rack is needed for opening the door for servicing.

2-4 LINE VOLTAGE MODIFICATION

a. GENERAL - The DDR-7B is factory wired for 115 VAC 50/60 cps, single phase line voltage unless specified otherwise on order. If line voltage is 190-, 200-, 210-, 230-, 240- or 250-VAC 50/60 cps single phase, insert TMC #TF-275 transformer between the DCP-2 unit and the rack a-c power strip as shown in figure A, Appendix and use appropriate taps on the transformer.

2-5 ASSEMBLY OF RECEIVER

Refer to table F (shipping List for DDR-7B) for parts and their functions. Install components as shown in figure 1-1 and make cable connections as described in figure A in Appendix of this manual. In some cases, some of the smaller parts may be partially assembled in shipment. The LSP-6, HSP-3, and DCP-2 units are shipped installed in the rack. The GPR-92, AFC-2A, NRC type 173 and 108 Oscillators, and SBS-I-1 units are slide-mounted; the track portion of the slides arrive installed in the rack. Referring to figure 2-1, follow this general procedure for installing slide-mounting units:

- (1) Set the component in position on the tracks.
- (2) Slide the component on the tracks until the release button catches.
- (3) Press the release buttons and push the component into the rack until the release buttons engage in the holes in the equipment.
- (4) When all the components have been installed and cabled, press the release buttons and push the component into the rack.

2-6 CONNECTION OF EXTERNAL EQUIPMENT

a. INTRODUCTION - Figure 2-2 illustrates external equipment connections for the DDR-7B. The following paragraphs describe each connection.

b. ANTENNA INPUTS - The input impedance at J104 antenna jack on each GPR-92 Receiver chassis rear has been designed to match an unbalanced 70-ohm transmission line. A mating series BNC, type UG-360/U plug is included in the shipment for each GPR-92.

c. AUDIO OUTPUTS - Of the three terminal blocks located on the HSP-3 Audio Switching Panel rear chassis, the top one (TB9203) is for connection of the external audio loads. There are 2 (channel A and B) outputs for each receiver system. Each output presents an adjustable 0- to 1-mw level a-f signal to a 600-ohm impedance load.

The load may be connected for balanced or unbalanced feed. The terminals are marked in the four groups. "CT" terminals are used for balanced outputs. "G" terminals may be used for shield and/or chassis ground connections.

d. LINE VOLTAGE INPUT - Connect 115VAC, 50/60 cps, single phase source to DDR-7B at the round receptacle located at the bottom of the rear door frame. A mating plug is supplied in shipment for this purpose. If line voltage is other than 115VAC, 50/60 cps, single phase, see paragraph 2-4 for modification procedure.

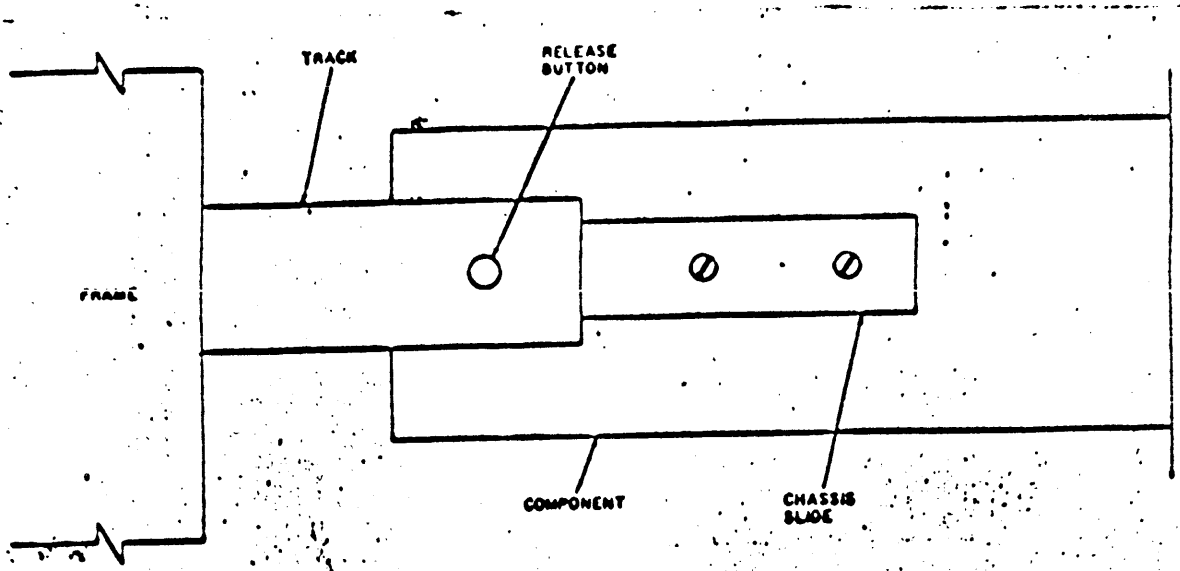

A. NON-TILTING SLIDE MECHANISM

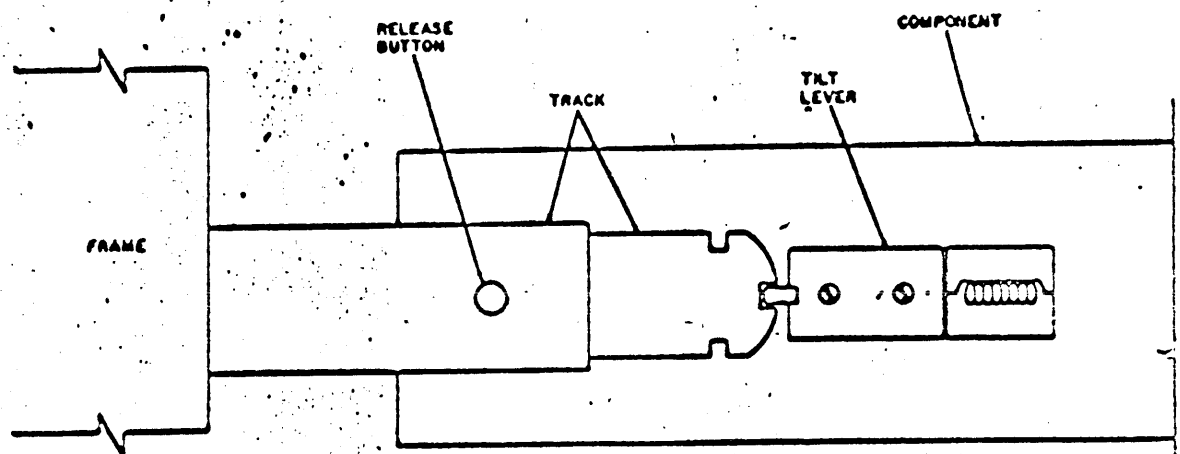

B. TILTING SLIDE MECHANISM

FIGURE 2-1. SLIDE-MOUNTING DETAILS

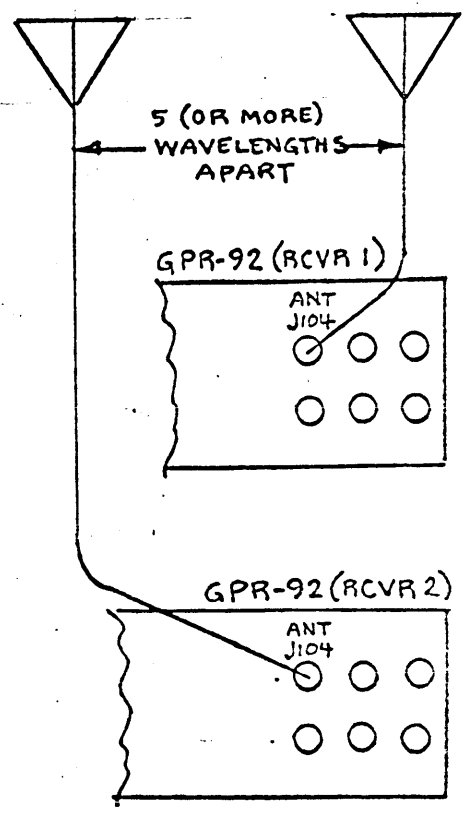
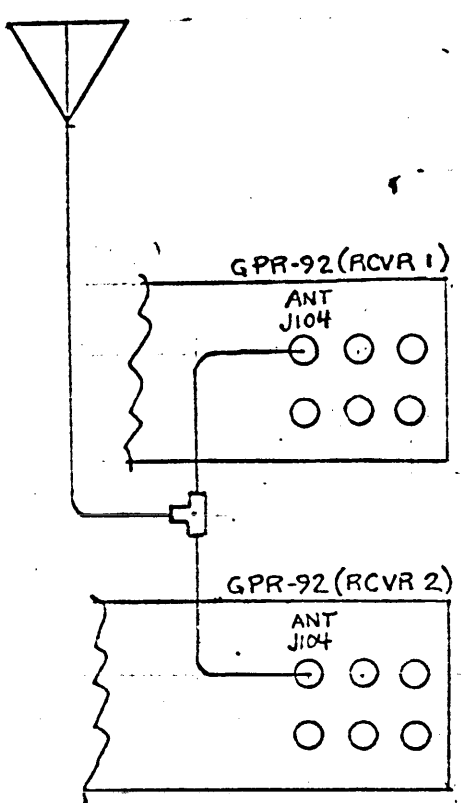
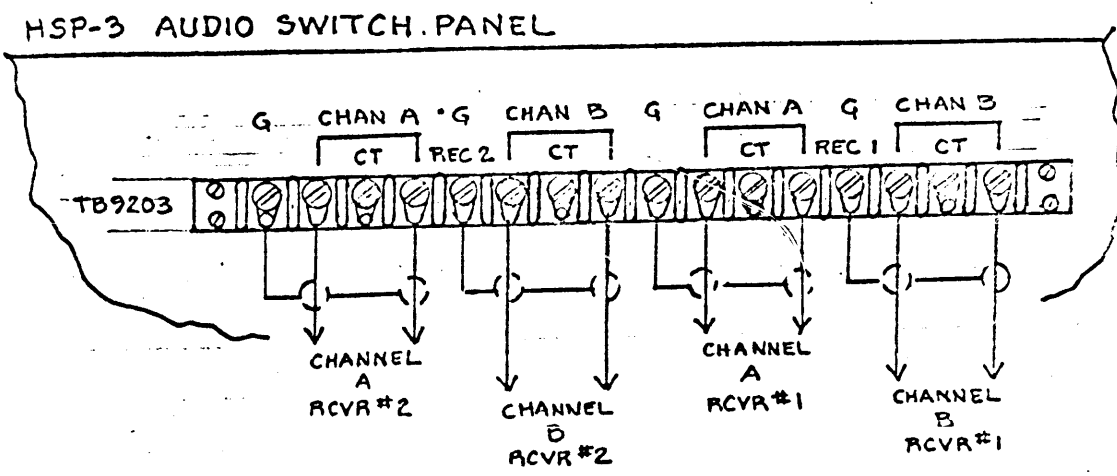

FIGURE 2-2. CONNECTION DIAGRAM, EXTERNAL EQUIPMENT TO DDR-7B

SECTION 3

OPERATOR'S SECTION

3-1 INTRODUCTION

a. GENERAL - Before tuning up the DDR-7B for the first time, it is advisable that the operator become familiar with the following characteristics and capabilities of the equipment:

- (1) Modes of reception
- (2) Functions of components
- (3) Functions of controls

b. MODES OF RECEPTION - The DDR-7B will operate as a dual diversity system or as two separate receiver systems to pick up the following modes of transmission:

- (1) CW (keyed carrier)
- (2) MCW (keyed 1-kc modulated carrier)
- (3) AM* (amplitude modulation)
- (4) SSB (single sideband) with suppressed or partial carrier
- (5) ISB (independent sidebands) with suppressed or partial carrier
- (6) FSK* (frequency shift keying)

In addition to these conventional modes of reception described above, it will become evident to the operator that, because of dual i-f passband selection and dual a-f detection and output channels in each receiver system, simultaneous reception is possible in each receiver system in such combinations as CW/SSB, AM/SSB, MCW/SSB, etc. Also the two receiver systems may be used in this way to receive two pairs, or a total of four different modes, if necessary.

* Single sideband reception from a transmitted AM signal.

c. FUNCTIONS OF COMPONENTS - The DDR-7B (see figure 3-1) is two receiver systems each consisting of a Model GPR-92 Communications Receiver, an NRC type 173, Model 2, Variable Master Oscillator, an NRC type 108, Model 2, Master Crystal Oscillator-Multiplier, a Model SBS-I-1A Sideband Selector, a Model AFC-2A Automatic Frequency Control, and one speaker in Model LSP-6 Speaker Panel.

In sideband reception the GPR-92 is used to tune in the signal in the r-f stage and convert it into a 455-kc i-f stage. The 455-kc i-f is routed to the SBS-I-1 unit where the signal is converted into a 250-kc i-f and then routed to the SBS-I-1 filter section. In SSB reception, the filter section passes the desired sideband onto a product detector. In sideband transmitted with no carrier, an artificial 250-kc carrier is injected into the product detector to produce audio. In sideband transmitted with partial carrier, the carrier is stripped out of the signal before it enters the sideband filters and routed through the AFC-2A unit before it is re-injected at the SBS-I-1 product detector. The AFC-2A serves to produce an automatic frequency control feature which keeps sidebands from drifting outside of the sideband filters due to transmitted frequency drift. The audio output of the product detector can then be routed to channel A or B lines. In ISB reception, each sideband is routed to a channel.

In reception of a transmitted AM signal, the sideband tuning feature of DDR-7B is used to an advantage. Audio is derived from one sideband by the same process used for tuning in a sideband signal. Since the transmitted AM signal contains a carrier, this is used to obtain the automatic frequency control in the same manner

* The center frequency of a received frequency shift (FSK) signal may be adjusted to any audio frequency output required to operate a frequency shift converter.

as a sideband transmitted with partial carrier. The two advantages gained are greater filtering and selectivity and the automatic frequency drift control. If the AM signal is exceptionally weak, however, it can be processed through an SBS-I-1 diode detector in the conventional manner in order to utilize all the transmitted power represented in carrier and sidebands.

In CW reception, the GPR-92 component alone can be used with a headset output in the GPR-92 a-f section, if one receiver system is being used. If diversity operation is required for CW, however, outputs must be taken at the SBS-I-1 units. In this case the HFO frequency from the Model 2 Oscillator is de-tuned sufficiently to slide the carrier through an SBS-I-1 sideband filter.

In MCW reception an advantage is also gained by the sideband tuning feature as it is for AM reception. Since the intelligence can be obtained from either upper or lower sideband tone, the signal takes the same course through the systems as an AM signal. The input at SBS-I-1A, which consists of carrier and both sideband tones ($F_c - 1kc$ and $F_c + 1kc$) is stripped of the carrier and one sideband tone. The other sideband tone slips through the sideband filter to the product detector where it is beat with the carrier returning from the AFC-2A to produce the keyed 1-kc tone originally transmitted. NRC Oscillator HFO and IFO is required for diversity but, for single receiver operation, the internal HFO of the GPR-92 is sufficient due to the AFC feature available.

In FSK reception, the NRC Oscillator HFO is de-tuned in order to translate mark and space frequencies into values necessary to operate a frequency shift converter at the DDR-7B audio output.

Since the GPR-92 HFO cannot be de-tuned, this method is used for diversity and single receiver operation. The de-tuning, based on frequency translation as described in paragraph 3-2 c (3), is also calculated to pass mark and space frequencies through one of the SBS-I-1 sideband filters. The filter output then goes to the product detector where it is beat with the SBS-I-1 250 kc oscillator output to produce the mark and space audio tones.

d. FUNCTIONS OF CONTROLS - Refer briefly to Operator's Section of each component manual (GPR-92, TRX-1, etc.) for functions of controls. The HSP-3 Audio Switch Panel has CHANNEL selector switches for routing the SBS-I-1 2 high-level outputs (channels A and B) to the speakers on LSP-6 Speaker Panel. VOLUME knobs control input levels to the speakers. The 3-position CHANNEL for each receiver system, selects three inputs for the speaker for that system. Receiver system #1 is composed of the uppermost components; the components below them make up receiver system #2. The speaker for receiver system #1 is on the left as the operator faces the control panel; the speaker for system #2 is on the right. Position "A" of the HSP-3 RECEIVER 1 CHANNEL switch routes receiver system #1 SBS-I-1 channel A output to the left speaker. In "OFF" position there is no input to the speaker. Position "B" connects channel B output to the speaker. The arrangement is identical for receiver system #2.

Setting AGC switch on HSP-3 Panel to SEPARATE position allows the two receiver systems to operate independently. Setting the switch to COMBINED causes the two systems to operate in diversity.

The EXT/INT switch on GPR-92 set in EXT position connects NRC Oscillator HFO, IFO and BFO outputs into the GPR-92. Setting the switch to INT disconnects the NRC Oscillator HFO, IFO and BFO outputs.

The AFC switch on SBS-I-1 connects the AFC-2A unit to the SBS-I-1 when set ON and disconnects it in the OFF position.

A-f controls on the GPR-92 are ineffective when using the SBS-I-1 unit, except for monitoring uses when tuning the GPR-92.

The BFO circuitry in NRC Oscillator-Multiplier has been modified for use in the DDR-7B, to produce the required 3.5-mc IFO oscillator for the second stage of conversion in the upper 3 bands of the GPR-92 Receiver. The 455-kc BFO to the GPR-92 comes from the NRC Type 173 Variable Master Oscillator. Therefore, the controls for the NRC Oscillator IFO output are the "BFO ON/OFF" and the "BFO CRYSTAL 1/2" switches on the front panel of the NRC Type 108 Oscillator-Multiplier and the control for the BFO output is the "BFO CRYSTAL 1/2" switch on the rear chassis of the NRC Type 173 Variable Master Oscillator. The crystal for each oscillator is in the socket corresponding with position "1" of each BFO CRYSTAL switch. In tables 3-1 through 3-10, it will be noticed that whenever the NRC oscillators are used, the NRC 455-kc BFO is always used for tuning-in the GPR-92 r-f stage. When the NRC oscillators are not used, switching the GPR-92 INT/EXT switch to INT disconnects the NRC BFO along with the HFO and IFO. Therefore, to facilitate tuning, it is advisable to set the NRC Type 173 Variable Oscillator BFO CRYSTAL switch on the unit's rear chassis to position "1" and leave it there.

3-2 TUNING PROCEDURES

a. TUNING TABLES - Tables 3-1 through 3-10 describe tuning procedures for a single receiver system for the 10 main modes of reception available with the DDR-7B. As the operator becomes

more familiar with the DDR-7B's capabilities it will become evident that there are many other modes of transmission and reception also available but not so frequently used. The tables serve to illustrate the more common modes.

Each table is set up for using specific channel outputs from SBS-I-1, although either or both channels may be used.

b. DIVERSITY TUNING - For frequency diversity operation, one receiver system is tuned to a point slightly above the carrier and the other receiver system is tuned to a point slightly below. For space diversity, both receiver systems are tuned directly on the carrier. For frequency or space diversity operation, each system is first tuned with the HSP-3 AGC switch in SEPARATE position. After tuning, the two systems are tied together for diversity operation by setting the AGC switch in COMBINED position. If an audio comparator is used at the output of the two receiver systems, the AGC switch remains in the SEPARATE position for diversity operation.

In tables 3-1 through 3-10, when tuning each receiver system for frequency diversity, " F_c " (carrier frequency) is interpreted to mean a point slightly above or slightly below F_c , as applies to the arrangement chosen.

c. NRC OSCILLATORS

(1) Function. - NRC Type 173, Model 2, Variable Master Oscillator is used to generate a 2-4 mc frequency of high stability. The 2-4 mc output is routed to the NRC Type 108, Model 2, Master Crystal Oscillator-Multiplier. Type 108 Oscillator serves to step up the 2-4 mc into the 2-32 mc range by frequency multiplication. The stabilized 2-32 mc output is then used for the external HFO input to the GPR-92 Receivers. In addition, Type 108 Oscillator supplies a 3.5-mc IFO and Type 173 Oscillator supplies a 455-kc BFO to the TMC GPR-92 Receivers.

(2) Type 173 Oscillator Aging and Warm-up. - Type 173 Variable Master Oscillator requires a preliminary aging period followed by a warm-up period in order to stabilize its oven temperature when used for the first time. After operation of the DDR-7B, it is placed in a standby condition, as described in paragraph (4), in order to eliminate subsequent repetition of the warm-up period when used again.

Aging the oscillator is accomplished as follows. Set DCP-2 MAIN POWER switch to ON. Leave NRC Power Supply (for Type 173 Oscillator) POWER switch set to OFF. Type 173 Oscillator XTAL OVEN lamp will light. Set 173 Oscillator OUTPUT switch to OFF. After 20 minutes, XTAL OVEN lamp will start to cycle. Wait 4 hours, then set DCP-2 MAIN POWER switch to OFF. Leave off for 4 hours, then set DCP-2 MAIN POWER switch to ON. Leave on for 4 hours, then shut off for 4 more hours before proceeding with the warm-up period.

The subsequent warm-up period is required to bring the oven to a stable temperature in order to produce the oscillator's rated frequency stability. Set the DCP-2 MAIN POWER switch to ON and wait for 18 hours before using equipment.

(3) HFO Setting for FSK Reception. - HFO settings for CW, MCW, AM, SSB and ISB are relatively simple and are spelled out in tables 3-1 through 3-9. The HFO calculation for FSK reception, however, is based on several factors as outlined here.

The HFO frequency for FSK ultimately produces a center audio frequency at the SBS-I-1 output. The "center" frequency (which is theoretical and not transmitted) is the frequency half-way between the space and mark frequencies. In its audio stage it is the operating frequency in most frequency shift converters, thereby permitting an adjustment in the converter to different shift values. A frequency shift converter is defined here as a component which translates mark and space audio signals into the necessary d-c pulse values to operate standard RTTY (radio teletype) equipment.

If a TMC Model CFA-1 Frequency Shift Converter (which has a center operating frequency of 2,550 cps) is to be used with the DDR-7B, the HFO frequency is determined as follows: -

Where F_c = transmitted r-f center frequency (in kc)

Where F_{hfo} = HFO frequency (in kc)

When F_c = .54 mc to 5.6 mc

$F_{hfo} = F_c + 457.550\text{kc}$ (when 3.5- or 6.0-kc LSB filter is used)

$F_{hfo} = F_c + 452.450\text{kc}$ (when 3.5- or 6.0-kc USB filter is used)

When F_c = 5.6 mc to 32.3 mc

$F_{hfo} = F_c + 3,957.550\text{kc}$ (when 3.5- or 6.0-kc LSB filter is used)

$F_{hfo} = F_c + 3,952.450\text{kc}$ (when 3.5- or 6.0-kc USB filter is used)

Ordinarily, the width of the sideband filter used determines the maximum frequency shift that can be passed by the DDR-7B. However, since the maximum frequency shift that can be passed by the CFA-1 is 1 kc and since any of the filters will pass this when the converter center frequency is 2.5 kc, any one of the 4 filters may be used.

If a frequency shift converter other than TMC Model CFA-1 is to be used, the HFO frequency is determined as follows: -

Where F_c = transmitted r-f center frequency (in kc)

Where F_{hfo} = HFO frequency (in kc)

Where F_{ac} = Operating audio center frequency of converter (in kc)

When $F_c = .54\text{ mc to }5.6\text{ mc}$

$F_{hfo} = F_c + 455\text{kc} + F_{ac}$ (when 3.5- or 6.0-kc LSB filter is used)

$F_{hfo} = F_c + 455\text{kc} - F_{ac}$ (when 3.5- or 6.0-kc USB filter is used)

When $F_c = 5.6\text{ mc to }32.3\text{ mc}$

$F_{hfo} = F_c + 3,955\text{kc} + F_{ac}$ (when 3.5- or 6.0-kc filter is used)

$F_{hfo} = F_c + 3,955\text{kc} - F_{ac}$ (when 3.5- or 6.0-kc USB filter is used)

Either an upper or lower sideband filter may be used but which width to use depends upon the operating audio center frequency

of the frequency shift converter. This determines the maximum frequency shift that can be passed by the DDR-7B. Figure 3-2 may be used to determine the maximum frequency shift that is available with the two sideband filter widths. It should be remembered, however, that the frequency shift converter may have a frequency shift limitation also and, if it is smaller than that of the DDR-7B, it will be the determining factor.

Example: - It is intended to receive an FSK signal, the transmitted center frequency of which is 15 mc. The total frequency shift (from space to mark) is 850 cps. The frequency shift converter has a maximum frequency shift capacity of 1 kc and a center operating frequency of 3.5 kc. The HFO frequency and which sideband filter to use are determined as follows: -

Referring to figure 3-2, it is seen that, with a converter with a center frequency of 3.5 kc, the DDR-7B will pass only a 15-cps maximum total shift (or 7.5 cps on either side of the 15 mc) when using the 3.5-kc width sideband filter. When using a 6-kc width filter, however, a 5.3-kc maximum total shift may be passed. Therefore the filter to use is the 6-kc width one. Since $F_c = 15 \text{ mc}$ and either the LSB or USB 6.0 kc filter may be used, there is an optional choice of two HFO frequencies: $F_c + 3,955 \text{ kc} + F_{ac}$ (18.9585 mc) with the LSB filter or $F_c + 3,955 \text{ kc} - F_{ac}$ (18.9515 mc) with the USB filter.

Once the HFO frequency and sideband filter has been determined, table 3-10 lists the steps necessary to tune NRC Type 173 and 108 Oscillators to produce the HFO frequency down to within 1 cps error.

(4) Standby Condition for Type 173 Oscillator. - After shutting down the DDR-7B, NRC Type 173 Oscillator may be placed

in standby condition which effectively maintains the oscillator's stabilized oven temperature in preparation for the next reception period. This is accomplished by shutting off all POWER switches except that of the DCP-2 unit. When the DCP-2 POWER switch is ON, a-c line voltage is fed only to the NRC Type 173 Oscillator oven heater elements and thermostat. Indication that the oscillator is in "standby" is shown in the DCP-2 POWER indicator light and the regular cycling of the NRC Type 173 Oscillator XTAL OVEN light.

d. BANDSPREAD. - Bandsread of the r-f stage is accomplished with the GPR-92 BANDSPREAD knob and movable dial. This control acts as a vernier adjustment for the GPR-92 TUNING control. Calibration markings on the BANDSPREAD dial are set up in the following 6 amateur bands: -

<u>Band (meters)</u>	<u>Frequency Range (mc)</u>
10-11 -----	26.8 - 30.0
15 -----	20.5 - 21.8
20 -----	13.9 - 14.5
40 -----	6.85 - 7.40
80 -----	3.45 - 4.10
160 -----	1.80 - 2.00

Although the calibration markings are presented for convenience in tuning in the amateur bands, the BANDSPREAD control may be used over the entire range of the receiver.

Example 1: To tune in an amateur frequency of 27.1 megacycles:

(1) Set BANDSPREAD control to "100" on BANDSPREAD LOG scale.

(2) Set TUNING control to "10-11M" mark on TUNING LOG scale.

(3) Bring BANDSPREAD reading down to "27.1" on 10-11M scale.

Example 2: To tune in a frequency of 17 megacycles:

(1) Set BANDSPREAD control to "100" on BANDSPREAD LOG scale.

(2) Set TUNING control to "17.5 mc"* on TUNING 9.4 - 17.8 scale.

(3) Using headset as a monitor, slowly decrease BANDSPREAD reading to area around "50" on LOG scale for best reception.

Once a station has been tuned in, the operator may record TUNING and BANDSPREAD LOG scale settings for future tuning to that frequency.

e. SLOT TUNING METHOD. - Tables 3-1 through 3-10 spell out specific settings of DDR-7B tuning controls to bring in the common types of transmission. However, in order to familiarize the operator with the flexible tuning features of the DDR-7B and the resulting capability of multiple simultaneous reception from more than one type of transmission, DDR-7B tuning theory is reduced to a simple analogy, referred to here as "slot

* By referring to the amateur band calibrations on the BANDSPREAD dial, it is seen that 17 mc falls between the 20-meter (13.9-14.5 mc) and 15-meter (20.5-21.8 mc) bands. Since the 20-meter adjustment gives an 0.6-mc adjustment and the 15-meter gives a 1.3-mc adjustment, by interpolation, the BANDSPREAD control will give approximately 0.9 mc of adjustment in the 17-mc area. Therefore, placing the TUNING dial at 17.45 (or 17.5) and the BANDSPREAD at the high end of the range should place 17 mc approximately in the middle of the total BANDSPREAD adjustment.

tuning".

Figure 3-3 is a series of diagrams illustrating the "slot tuning" or relative positioning of GPR-92 and SBS-I-1 pass-bands in order to receive the common types of transmission with a high degree of selectivity. In these diagrams, the GPR-92 and SBS-I-1 units are represented by movable slots and their positions are shown in relation to the stationary frequency spectrum of the transmitted signal.

In the "slot tuning" analogy, tuning a DDR-7B receiver system may be interpreted as follows:

(1) The GPR "slot" is one of variable length, adjusted by the GPR IF SELECTIVITY switch. When the switch is set in the 15-kc, 7.5-kc, 3-kc, 2-kc, 1-kc and .5-kc positions, the slot is adjusted to the corresponding lengths.

(2) The GPR "slot" is "moved" up and down the stationary transmitted frequency spectrum by increasing and decreasing, respectively, the GPR TUNING and BANDSPREAD frequency settings. Conversely, increasing the NRC Oscillator HFO frequency moves the GPR slot down and decreasing it moves the slot up.

(3) The SBS lower sideband "slot" comes in two lengths, 3.5- and 6-kc, selected by the SBS IF BANDWIDTH KC switches for channels A or B output. The upper sideband 3.5- and 6-kc "slots" are similarly selected.

(4) The SBS sideband "slots" are positioned along the stationary transmitted frequency spectrum to pass the sidebands and reject the carrier frequency (F_c) by setting the NRC Oscillator HFO output at $F_c + 455\text{kc}$ (when F_c falls within 0.54- to 5.6-mc range) or at $F_c + 3,955\text{kc}$ (when F_c falls within 5.6- to 32.3-mc range). When the NRC Oscillators are not used and GPR-92 internal oscillators are used, tuning the GPR-92 to F_c

automatically positions the SBS "slot" to pick up a sideband.

(5) The SBS sideband "slot" (either upper sideband or lower) is "moved" up the stationary transmitted frequency spectrum by increasing the NRC Oscillator HFO output frequency from the point set in (4). The "slot" is moved down the spectrum by decreasing the NRC Oscillator HFO output frequency. Each change in the NRC Oscillator HFO frequency is directly reflected by the same amount of change in the SBS slot position. (Example: A 500-cps increase in the HFO moves the SBS slot 500 cps up the transmitted frequency spectrum.)

(6) With the NRC Oscillator switched out of the system, de-tuning the GPR-92 from F_c also moves the SBS "slot." This method is not used, however, since there are disadvantages to de-tuning the GPR-92.

(7) The AFC "slot", which is approximately 50 cps long, may be considered attached to the SBS "slot" and moves with it. When the SBS slot is positioned to pass a sideband the AFC slot is automatically positioned in the area of the spectrum containing the carrier (F_c).

(8) After the SBS "slot" has been positioned to pick up a sideband, the AFC "slot", since it is only 50 cps long, needs a fine adjustment in order to pick up the carrier (F_c). This is done with the AFC-2A TUNING KCS knob which provides an adjustment of 3 kc in either direction from "0". However, moving the AFC "slot" also moves the SBS slot in the same direction. Turning the AFC-2A TUNING KCS knob towards plus (+) moves the AFC and SBS slots downward; turning the knob towards minus (-) moves the slots upward.

It will be noted that, in all arrangements shown in figure 3-3, the GPR "slot" is centered directly on the carrier (F_c), even though the carrier is often transmitted at a partially suppressed level or there is no carrier at all.

f. SLOT TUNING VS. RECEPTION MODE. - Figure 3-3A shows slot positioning for picking up a lower sideband of 3-kc width transmitted with a partial carrier. With partial carrier transmissions, (diversity or non-diversity) the NRC Oscillators are not used since the AFC-2A unit compensates for frequency drift in the receiver as well as in the transmitted signal. In figure 3-3A, the GPR-92 is tuned to F_c , centering the GPR slot on F_c . This automatically positions the SBS 3.5L slot to pass the lower sideband only and the AFC slot to pick up the carrier (F_c). Figure 3-3B shows the corresponding arrangement for upper sideband reception. Figure 3-3C shows the arrangement for receiving a 6-kc width lower sideband with partial carrier. The GPR slot is again centered on F_c and the SBS lower sideband slot is selected at a 6-kc length. The corresponding diagram for 6-kc width upper sideband reception is shown in figure 3-3D. Figure 3-3E shows the arrangement for ISB reception of two 3-kc channels of separate intelligence transmitted with partial carrier. In this diagram, each sideband goes to one of the two channels. Figure 3-3F shows the corresponding arrangement for ISB reception of two 6-kc bands. Figure 3-3G shows the slot arrangement for receiving a 3-kc lower sideband signal transmitted without a carrier. Since there is no carrier, the AFC-2A unit cannot be used and the added frequency stability of the NRC Oscillators is now required. The GPR-92 is tuned to F_c , centering the GPR on F_c . The NRC Oscillator HFO is

set for $F_c + 455\text{kc}$ (when $F_c = 0.54\text{- to } 5.6\text{-mc}$) or $F_c + 3,955\text{ kc}$ (when $F_c = 5.6\text{- to } 32.3\text{-mc}$). This positions the SBS slot to pass the sideband only. Corresponding slot positions for upper sideband transmitted without carrier is shown in figure 3-3H. Figures 3-3I and 3-3J show conditions for receiving the wider sideband signals without carrier. Figure 3-3K shows tuning methods for receiving a 6-kc wide ISB signal transmitted without carrier. Figure 3-3L is the corresponding arrangement for receiving a 12-kc wide ISB transmission without carrier. Figure 3-3M shows how the sideband tuning feature in the DDR-7B may be utilized to pick up the intelligence from the lower sideband of a 6-kc wide AM signal. Since the carrier is present, the AFC-2A unit may be used and the NRC Oscillators are not required. The GPR slot is centered on F_c which centers the SBS slot to pick up the lower sideband and the AFC slot to pick up the carrier. Figure 3-3N shows the slot pattern for obtaining intelligence from the upper sideband of the same signal. Figures 3-3(O) and 3-3P show arrangements for wide-band AM transmission. Figures 3-3Q and 3-3R shows slot positions when a narrow-band AM transmission is processed in the conventional manner through a diode detector in the SBS-I-1 unit. One sideband and carrier is routed to the detector. To do this, the SBS slot must be moved over to include the carrier. Since the SBS slot movement moves the AFC slot away from F_c , the AFC-2A unit cannot be used; however, the AFC feature is not required since the carrier-to-sideband relationship remains the same through the diode detector. The AFC slot is moved by means of the AFC-2A TUNING/KCS knob, thereby moving the SBS slot with it. This method is used to eliminate

the need for re-tuning the NRC Oscillator HFO from its normal value in order to move the SBS slot. This tuning method is only used when the transmitted AM signal is so weak that the full power present in the carrier must be utilized. Figures 3-2S and 3-2T are the corresponding patterns for weak wide-band AM transmission. Figure 3-3U illustrates slot appearance when the GPR is used alone to pick up a CW signal, using the headset at GPR as the output. The GPR slot is adjusted down to a 0.5-kc length to filter out adjacent frequencies. With this arrangement the pitch of the audio tone may be changed by means of the GPR BFO PITCH knob. Figure 3-3V shows the conditions when a higher frequency stability is desired and the NRC Oscillators are also used. The GPR BFO PITCH control is now inoperative; the audio tone depends on the NRC Type 173 MAIN TUNING knob (HFO) setting (see table 3-2, step 8). Figure 3-3W adds in the SBS unit for receiving the CW transmission if it is desired to take the output from the SBS. The SBS slot must now be moved over by adjustment of the NRC Oscillator HFO to pass the carrier (F_c). For this illustration, the 3.5L slot is used and moved up by 1 kc by increasing the NRC Oscillator HFO by 1 kc. The carrier is routed through the SBS product detector where, in its 250-kc i-f stage, it now appears as 249-kc. Since the product detector injection frequency is 250 kc, a 1-kc audio tone is produced. If a 2-kc or 3-kc tone is preferred, the NRC Oscillator HFO may be set 2- or 3-kc higher, respectively. Figure 3-3X shows the appearance of the GPR slot when the GPR is used alone to pick up MCW transmission using the GPR headset for output. In this case, both sideband tones and carrier are picked up and processed through the GPR AM diode detector by

setting the GPR MODE switch to AM. The audio tone produced is the modulating tone transmitted. This tone may not be altered by de-tuning the GPR BANDSPREAD control. Figure 3-3Y shows the conditions present when the NRC Oscillator is switched into the circuit for greater stability. Setting the NRC Oscillator HFO frequency to that shown in the figure will produce the original modulating tone. Changing the NRC Oscillator frequency will not change the tone. Figure 3-3Z adds the SBS into the system when it is required to use the SBS output in MCW reception. The intelligence is contained in either sideband tone, $F_c - 1$ kc or $F_c + 1$ kc; as a result the SBS slot may be positioned as for sideband reception and one tone may be picked up. Figure 3-3Z illustrates the lower sideband tone, $F_c - 1$ kc. The AFC may now be used to compensate for transmitted carrier drift and the NRC Oscillators can be switched out. Figure 3-3AA shows the arrangement for picking up the upper sideband tone. Figure 3-3AB shows the slot arrangement for receiving an FSK signal with an 850-cps shift and the NRC Oscillator HFO tuned to produce a 2,550 cps center frequency at the audio output. Slots may be arranged for different shifts and different audio center frequencies, if necessary. The GPR and SBS slots are adjusted to pass these frequencies and also to produce a certain center frequency by frequency translation as described in paragraph 3-2c (3).

f. AGC SYSTEMS

(1) General.- There are two main AGC (automatic gain control) systems that may be used in operating the DDR-7C:--the GPR-92 and SBC-I-1A systems. Only one of the two main systems can be used at one time. The SBC-I-1A AGC system is further divided into four systems, as described in paragraph 3-2f(3).

(2) GPR-92 AGC System. - The GPR-92 AGC System consists of an AGC source originating in the GPR-92 i-f output and fed back to the GPR-92 input i-f and r-f amplifiers. This system may be used when the incoming signal has a constant component in it, such as the carrier in an MCW or AM signal. For diversity operation, before tuning the DDR-7B open the back service door and disconnect wires #28 and #27 from terminal #10 of each of the input terminal blocks on the rear chassis of HSP-3 Audio Switch Panel (see figure A, Appendix). Replace with wires #11 and #22 of the same cable. The SBC AGC system is shut off by placing the SBS-I-1 AGC SELECTOR switch at MANUAL and setting the AGC MANUAL knob to some suitable point to regulate the gain of the SBS-I-1 i-f input amplifier tube.

(3) SBC -I-1A AGC System. - The SBC-I-1A AGC system consists of four different AGC sources that may be selected by the SBS-I-1 AGC SELECTOR switch. CH-A position selects a source from the output of the SBS-I-1 channel A i-f sideband output; CH-B position is for a source from channel B i-f sideband output. CH-A-B selects a source from a comparator at the output of both channels. The CARRIER position selects an AGC signal originating in the received carrier in the AFC-2A unit. The selected source is then routed to the SBS-I-1 input amplifier tube where it regulates its gain. The response speed of the AGC action may be further adjusted by the AGC RESPONSE switch in SLOW, MED, or FAST positions. This system may be used for any type of reception, but is particularly effective in receiving intermittent signals (CW, SSB, ISB, and FSK) due to the response speed adjustment available. For diversity operation, before tuning the DDR-7B, open the back service door and disconnect wires #11 and #22 from terminal #10 of each of the input terminal blocks

on the rear chassis of the HSP-3 unit (see figure A, Appendix). Replace with wires #28 and #27 of the same cable. The GPR-92 AGC system is shut off by placing the AVC/MANUAL switch in MANUAL position.

NOTE

The r-f signal strength registering on the GPR-92 RF/AF "S"-meter works off of the AGC signal. For momentary checks on incoming signal strength in MCW and AM reception, set the AVC/MANUAL switch to AVC. For CW, SSB, ISB, and FSK reception the signal strength may be observed as represented in the a-f portion of the GPR-92. In this case, the AVC/MANUAL switch may be left on MANUAL and the a-f level read by turning up the LINE LEVEL knob and holding down the RF/AF button.

(4) Selection of AGC System.- Specific AGC settings are spelled out in tables 3-1 through 3-10. However, some experimentation is advisable, due to particular characteristics of the signal and transmitting conditions.

TABLE 3-1. TUNE-UP PROCEDURE FOR CW (USING GPR-92 ALONE,
NON-DIVERSITY)

STEP	MODULE	OPERATION
1	SBS-I-1 & NRC units	POWER switches to STANDBY or OFF.
2	DCP-2	MAIN POWER switch to ON. MAIN POWER lamp will light. SBS-I-1 STANDBY lamp will light. Rack blower will start.
3	GPR-92	Preliminary Setting: - MONITOR AUDIO knob fully CCW. LINE LEVEL knob to mid-position. RF GAIN knob fully CW. TUNING and BANDSPREAD dials will light up. ANT TUNE knob to vertical position. SEND/RECEIVE switch to RECEIVE. INT/EXT switch to INT. NOISE LIMITER knob to OFF. LIMITER switch to OFF. SQUELCH knob fully CCW. AVC/MANUAL switch to MANUAL.
4	GPR-92	Coarse Tuning: - BFO PITCH knob to + 1.5 KC. MODE switch to CW. RANGE SELECTOR switch for frequency to be received. IF SELECTIVITY switch to 15 KC. HFO TRIM knob to 0. TUNING and BANDSPREAD knobs for frequency to be received.
5	GPR-92	Fine Tuning: - Insert headset at PHONES jack. Adjust LINE LEVEL and MONITOR AUDIO knobs for usable single level. Readjust BANDSPREAD knob to obtain desired signal. Hold down RF/AF button and adjust ANT TUNE knob for peak reading on meter. Release button. Set IF SELECTIVITY switch for cleanest tone at headset. Readjust MONITOR AUDIO knob for desirable volume and BFO PITCH knob for best listening tone.

TABLE 3-2. TUNE-UP PROCEDURE FOR CW (USING GPR-92 AND NRC OSCILLATORS, NON-DIVERSITY)

STEP	MODULE	OPERATION
1		If NRC Type 173 Variable Master Oscillator has been previously placed in standby condition (see paragraph 3-2 c (4)) do not perform step 2 but proceed with step 3. If the Oscillator has not been placed in standby, perform step 2, then 3, etc.
2	DCP-2	MAIN POWER switch to ON. MAIN POWER lamp will light. Rack blower will start. After 20 minutes, NRC Type 173 Variable Master Oscillator XTAL OVEN lamp will start to cycle. Wait 18 hours for oven stabilization before proceeding with step 8.
3	SBS-I-1	POWER switch to STANDBY. STANDBY lamp will light.
4	GPR-92	<u>Preliminary Settings:</u> - MONITOR AUDIO knob fully ccw. LINE LEVEL knob to mid-position. RF GAIN knob fully cw. TUNING and BANDSPREAD dials will light up. ANT TUNE knob to vertical position. SEND/RECEIVE switch to RECEIVE. INT/EXT switch to EXT. NOISE LIMITER knob to OFF. LIMITER switch to OFF. SQUELCH knob fully ccw. AVC/MANUAL switch to MANUAL.
5	GPR-92	<u>Coarse Tuning:</u> - MODE switch to CW. RANGE SELECTOR switch for frequency to be received (F_c). IF SELECTIVITY switch to c 15KC. TUNING and BANDSPREAD knobs for frequency to be received (F_c).

TABLE 3-2. TUNE-UP PROCEDURE FOR CW (USING GPR-92 AND NRC OSCILLATORS, NON-DIVERSITY) (Con't)

STEP	MODULE	OPERATION
6	NRC Type 108, Model 2, Oscillator	POWER switch to ON. POWER lamp and 1 and 2 OVEN HEATER lamps will light. BFO switch to ON. HFO switch to ON. HFO CRYSTAL switch to EXT. Calculate HFO frequency on the basis of F_c^* . Set OUTPUT FREQUENCY knob and HFO MULTIPLIER knob to produce HFO frequency as a product. (Example: for HFO of 8.553,285 mc, set OUTPUT FREQUENCY knob to 2.13 and HFO MULTIPLIER knob to X4 position.) BFO CRYSTAL switch to 1. HFO OUTPUT knob at mid-position.
7	NRC Type 173, Model 2 Oscillator Power Supply	POWER switch to ON. POWER lamp will light.
8	NRC Type 173 Model 2 Oscillator	FREQ LOCK switch to OFF. OUTPUT switch to OFF. BFO CRYSTAL switch (on chassis rear) to 1. MAIN TUNING knob to bring $\frac{HFO \text{ frequency} + F_t^{**}}{M^{***}}$ on display counters (to within 400 cycles maximum). Set 3 LOCKING DIGITS switches on the numbers for the last 3 digits of the $\frac{HFO + F_t}{M}$ frequency. FREQUENCY LOCK switch

* HFO frequency to equal $F_c + 455\text{kc}$ (when $F_c = 0.54\text{- to } 5.6\text{-mc}$) or $F_c + 3,955\text{kc}$ (when $F_c = 5.6\text{- to } 32.3\text{-mc}$)

** F_t = frequency of audio tone desired

*** M is FREQUENCY MULTIPLIER knob setting multiplication factor, (1, 2, 4 or 8), from step 6.

TABLE 3-2. TUNE-UP PROCEDURE FOR CW (USING GPR-92 AND NRC OSCILLATOR, NON-DIVERSITY) (Con't)

STEP	MODULE	OPERATION
8 (con't)		to ON. Wait for oscillator to "pull" to correct frequency as indicated by digits appearing on last 3 columns of digit display and flashing HIGH and LOW lights. When digits appear correctly and HIGH and LOW lights have stopped flashing, observe CORRECTION STRENGTH meter. If oven has stabilized properly, meter will read in NORMAL RANGE. OUTPUT switch to ON. OUTPUT lamp will light.
9	GPR-92	<u>Fine Tuning:</u> - Insert headset at PHONES jack. Adjust LINE LEVEL and MONITOR AUDIO knobs for usable signal level. Readjust BAND-SPREAD knob to obtain desired signal. Hold down RF/AF button and adjust ANT TUNE knob for peak reading on meter. Release button. Set IF SELECTIVITY switch for cleanest tone at headset. Readjust MONITOR AUDIO knob for desirable volume.

TABLE 3-3. TUNE-UP PROCEDURE FOR MCW (USING GPR-92 ALONE, NON-DIVERSITY)

STEP	MODULE	OPERATION
1	SBS-I-1 & NRC units	POWER switches to STANDBY or OFF.
2	DCP-2	MAIN POWER switch to ON. MAIN POWER lamp will light. SBS-I-1 STANDBY lamp will light. Rack blower will start.
3	GPR-92	Preliminary Settings: - MONITOR AUDIO knob fully CCW. LINE LEVEL knob to mid-position. RF GAIN knob fully CW. TUNING and BAND SPREAD dials will light up. ANT TUNE knob to vertical position. SEND/RECEIVE switch to RECEIVE. INT/EXT switch to INT. NOISE LIMITER knob to OFF. LIMITER switch to OFF. SQUELCH knob fully CCW. AVC/MANUAL switch to MANUAL.
4	GPR-92	Coarse Tuning: - MODE switch to AM. RANGE SELECTOR switch for frequency to be received. IF SELECTIVITY switch to 15 KC. HFO TRIM knob to 0. TUNING and BANDSPREAD knobs for frequency to be received.
5	GPR-92	Fine Tuning: - Insert headset at PHONES jack. Adjust LINE LEVEL and MONITOR AUDIO knobs for usable signal level. Readjust BANDSPREAD knob to obtain desired signal. Hold down RF/AF button and adjust ANT TUNE knob for peak reading on meter. Release button. Set IF SELECTIVITY switch for cleanest tone at headset. Set LIMITER/OFF switch to LIMITER or OFF (for best results). AVC/MANUAL to AVC. Readjust MONITOR AUDIO knob for desirable volume.

TABLE 3-4. TUNE-UP PROCEDURE FOR MCW (USING GPR-92, SBS-I-1 AND AFC-2A WITH CHANNEL A OUTPUT, DIVERSITY OR NON-DIVERSITY)

STEP	MODULE	OPERATION
1	HSP-3	AGC switch to SEPARATE. If speaker is to be used, set RECEIVER #1 (or #2) SPEAKER CHANNEL SELECTOR switch to A. Other RECEIVER SPEAKER CHANNEL SELECTOR switch to OFF.
2	SBS-I-1 & NRC units	POWER switches to STANDBY or OFF.
3	DCP-2	MAIN POWER switch to ON. MAIN POWER lamp will light. SBS-I-1 STANDBY lamp will light. Rack blower will start.
4	GPR-92	Preliminary Settings: - MONITOR AUDIO knob fully CCW. LINE LEVEL knob to mid-position. RF GAIN knob fully CW. TUNING and BANDSPREAD dials will light up. ANT TUNE knob to vertical position. SEND/RECEIVE switch to RECEIVE. INT/EXT switch to INT. NOISE LIMITER knob to OFF. LIMITER switch to OFF. SQUELCH knob fully CCW. AVC/MANUAL switch to MANUAL.
5	GPR-92	Coarse Tuning: - MODE switch to AM. RANGE SELECTOR switch for frequency to be received. IF SELECTIVITY switch to 15 KC. HFO TRIM knob to 0. TUNING and BANDSPREAD knobs for frequency to be received.
6	GPR-92	Fine Tuning: - Insert headset at PHONES jack. Adjust LINE LEVEL and MONITOR AUDIO knobs for usable signal level. Readjust BANDSPREAD knob to obtain desired signal. Hold down RF/AF button and adjust ANT TUNE knob for peak reading on meter. Release button. Set IF SELECTIVITY switch for cleanest tone at headset. MANUAL/AVC switch to AVC. LINE LEVEL knob fully CCW.

TABLE 3-4. TUNE-UP PROCEDURE FOR MCW (USING GPR-92, SBS-I-1 AND AFC-2A WITH CHANNEL A OUTPUT, DIVERSITY OR NON-DIVERSITY) (Cont)

STEP	MODULE	OPERATION
7	SBS-I-1	POWER switch to ON. STANDBY lamp will go out. POWER ON lamp will light and SBS-I-1 blower will start. AFC switch to OFF. CHANNEL A LEVEL ADJUST knob to mid-position. CHANNEL B LEVEL ADJUST knob fully CCW. CHANNEL A IF BANDWIDTH KC switch to 3.5L. CHANNEL A DETECTION switch to CW. AGC SELECTOR switch to A. CHANNEL A AGC RESPONSE switch to SLOW. Insert headset at MONITOR jack and adjust MONITOR GAIN knob to obtain usable volume of 1-kc tone on headset.
8	AFC-2A	CARRIER SELECTOR switch to OSC. TUNING/KCS knob to O. SENSITIVITY knob fully CW.
9	SBS-I-1	AFC switch to ON.
10	AFC-2A	Observe LEVEL meter. Hold down RESET button and adjust TUNING/KCS knob to obtain peak reading. Release RESET button. Monitor 1-kc tone with headset at SBS-I-1 MONITOR jack. When keying starts, observe LEVEL meter. Needle will remain steady through keying if AFC-2A is locked on carrier. If needle is not steady, AFC-2A is locked on a sideband tone; in this case, repeat step 10.
11	SBS-I-1	Listen to signal at headset. Set CH A IF BANDWIDTH KC switch to 3.5U and compare signal with switch setting at 3.5L. Choose clearest signal setting. Adjust CHANNEL A LEVEL ADJUST knob for proper output level.
12	HSP-3	If speaker output is used, adjust RECEIVER 1 (or RECEIVER 2) VOLUME knob for proper volume.

TABLE 3-5. TUNE-UP PROCEDURE FOR SSB WITH PARTIAL CARRIER* (USING GPR-92, SBS-I-1 AND AFC-2A WITH CHANNEL A OUTPUT, DIVERSITY OR NON-DIVERSITY)(Cont)

STEP	MODULE	OPERATION
1	HSP-3	AGC switch to SEPARATE. If speaker is to be used, set RECEIVER #1 (or #2) SPEAKER CHANNEL SELECTOR switch to A. Other SPEAKER CHANNEL SELECTOR switch to OFF.
2	SBS-I-1 & NRC units	POWER switches to STANDBY or OFF.
3	DCP-2	MAIN POWER switch to ON. MAIN POWER lamp will light. SBS-I-1 STANDBY lamp will light. Rack blower will start.
4	GPR-92	<u>Preliminary Settings:</u> - MONITOR AUDIO knob fully CCW. LINE LEVEL knob to mid-position. RF GAIN knob fully CW. TUNING and BANDSPREAD dials will light up. ANT TUNE knob to vertical position. SEND/RECEIVE switch to RECEIVE. INT/EXT switch to INT. NOISE LIMITER knob to OFF. SQUELCH knob fully CCW. AVC/MANUAL switch to MANUAL
5	GPR-92	<u>Coarse Tuning:</u> - MODE switch to SSB. HFO TRIM knob to 0. BFO PITCH knob to 0. RANGE SELECTOR switch for frequency to be received. TUNING and BANDSPREAD knobs for frequency to be received. IF SELECTIVITY switch to 15 KC.
6	GPR-92	<u>Fine Tuning:</u> - Insert headset at PHONES jack. Adjust LINE LEVEL and MONITOR AUDIO knobs for usable signal level. Readjust BANDSPREAD knob to obtain desired signal and to eliminate "beat" note or to bring it to as low a tone as possible. (Note: Beat is produced by carrier and GPR-92 BFO while GPR-92 is detuned). Hold down RF/AF button and adjust ANT TUNE knob for peak reading on meter. Release button. LINE LEVEL knob fully CCW.

* SSB transmitted with a carrier suppressed no lower than 30 db below PEP.

TABLE 3-5. TUNE-UP PROCEDURE FOR SSB WITH PARTIAL CARRIER* (USING GPR-92, SBS-I-1A AND AFC-2A WITH CHANNEL A OUTPUT, DIVERSITY OR NON-DIVERSITY) (Cont)

STEP	MODULE	OPERATION
7	SBS-I-1	POWER switch to ON. STANDBY lamp will go out. POWER ON lamp will light and SBS-I-1 blower will start. AFC switch to OFF. CHANNEL A LEVEL ADJUST knob to mid-position. CHANNEL B LEVEL ADJUST knob fully CCW. CHANNEL A IF BANDWIDTH KC switch to 3.5L, 6.0L, 6.0U or 3.5U, depending on which sideband is being transmitted and its width. CHANNEL A DETECTION switch to SSB. AGC SELECTOR switch to A. CHANNEL A AGC RESPONSE switch to SLOW. Insert headset at MONITOR jack and adjust MONITOR GAIN knob toward "A" to obtain usable volume of signal on headset.
8	AFC-2A	CARRIER SELECTOR switch to OSC. TUNING/KCS knob to 0. SENSITIVITY knob fully CW.
9	SBS-I-1	AFC switch to ON.
10	AFC-2A	Observe LEVEL meter. Hold down RESET button and adjust TUNING/KCS knob to obtain peak reading. Release RESET button. Monitor signal with headset at SBS-I-1 MONITOR jack. Observe DRIFT meter. DRIFT meter needle will remain steady through signal tone variations if AFC-2A is locked on carrier. If needle is not steady, AFC-2A is locked on the sideband; in this case, repeat step 10 until it locks onto the carrier.
11	SBS-I-1	Adjust CHANNEL A LEVEL ADJUST knob for proper output level.
12	HSP-3	If speaker output is used, adjust RECEIVER 1 (or RECEIVER 2) VOLUME knob for proper volume.

* SSB transmitted with a carrier suppressed no lower than 30 db below PEP

TABLE 3-6. TUNE-UP PROCEDURE FOR SSB WITH FULLY SUPPRESSED CARRIER (USING GPR-92, NRC OSCILLATORS AND SBS-I-1 WITH CHANNEL A OUTPUT, DIVERSITY OR NON-DIVERSITY)

STEP	MODULE	OPERATION
1		If NRC Type 173 Variable Master Oscillator has been previously placed in standby condition (see paragraph 3-2 c (4)), do not perform step 2 but proceed with step 3. If the Oscillator has not been placed in standby, perform step 2.
2	DCP-2	MAIN POWER switch to ON. MAIN POWER lamp will light. Rack blower will start. After 20 minutes, NRC Type 173 Variable Master Oscillator XTAL OVEN lamp will start to cycle. Wait 18 hours for oven stabilization before proceeding with step 9.
3	HSP-3	AGC switch to SEPARATE. If speaker is to be used, set RECEIVER #1 (or #2) SPEAKER CHANNEL SELECTOR switch to A. Other SPEAKER CHANNEL SELECTOR switch to OFF.
4	SBS-I-1	POWER switch to STANDBY. STANDBY lamp will light.
5	GPR-92	<u>Preliminary Settings:</u> - MONITOR AUDIO knob fully ccw. LINE LEVEL knob to mid-position. RF GAIN knob fully cw. TUNING and BAND-SPREAD dials will light up. ANT TUNE knob to vertical position. SEND/RECEIVE switch to RECEIVE. INT/EXT to EXT. NOISE LIMITER knob to OFF. LIMITER switch to OFF. SQUELCH knob fully ccw. AVC/MANUAL switch to MANUAL.
6	GPR-92	<u>Coarse Tuning:</u> - MODE switch to SSB. RANGE SELECTOR switch for frequency of suppressed carrier (F_c). IF SELECTIVITY switch to 7.5KC (for 3-kc sideband) or 15KC (for 6-kc sideband). TUNING and BAND-SPREAD knobs for F_c .

TABLE 3-6. TUNE-UP PROCEDURE FOR SSB WITH FULLY SUPPRESSED CARRIER (USING GPR-92, NRC OSCILLATORS AND SBS-I-1 WITH CHANNEL A OUTPUT, DIVERSITY OR NON-DIVERSITY) (Con't)

STEP	MODULE	OPERATION
7	NRC Type 108, Model 2 Oscillator	POWER switch to ON. POWER lamp and 1 and 2 OVEN HEATER lamps will light. BFO switch to ON. HFO switch to ON. HFO CRYSTAL switch to EXT. Calculate HFO frequency on the basis of F_c (suppressed carrier frequency)*. Set OUTPUT FREQUENCY knob and HFO MULTIPLIER switch to produce HFO frequency as a product. (Example: for HFO of 8.553,285 mc, set OUTPUT FREQUENCY knob to 2.13 and HFO MULTIPLIER knob to X4 position.) BFO CRYSTAL switch to 1. HFO OUTPUT knob at mid-position.
8	NRC Type 173, Model 2, Oscillator Power Supply	POWER switch to ON. POWER lamp will light.
9	NRC Type 173, Model 2 Oscillator	FREQ LOCK switch to OFF. OUTPUT switch to OFF. BFO CRYSTAL switch (on chassis rear) to 1. MAIN TUNING knob to bring $\frac{\text{HFO frequency}}{M^{**}}$ on display counters (to within 400 cycles maximum). Set 3 LOCKING DIGITS switches on the numbers for the last 3 digits of the $\frac{\text{HFO}}{M}$ frequency. FREQUENCY LOCK switch to ON. Wait for oscillator to "pull" to correct frequency as indicated by digits appearing on last 3 columns of digit display and flashing HIGH and LOW lights.

* HFO frequency to equal $F_c + 455\text{kc}$ (when $F_c = 0.54\text{- to } 5.6\text{-mc}$) or $F_c + 3,955\text{kc}$ (when $F_c = 5.6\text{- to } 32.3\text{-mc}$)

** M is FREQUENCY MULTIPLIER knob setting multiplication factor (1, 2, 4 or 8) from step 7.

TABLE 3-6. TUNE-UP PROCEDURE FOR SSB WITH FULLY SUPPRESSED CARRIER (USING GPR-92, NRC OSCILLATORS AND SBS-I-1 WITH CHANNEL A OUTPUT, DIVERSITY OR NON-DIVERSITY) (Con't)

STEP	MODULE	OPERATION
9 (Con't)		When digits appear correctly and HIGH and LOW lights have stopped flashing, observe CORRECTION STRENGTH meter. If oven has stabilized properly, meter will read in NORMAL RANGE. OUTPUT switch to ON.-OUTPUT lamp will light.
10	GPR-92	<u>1st Fine Tuning:</u> - Insert headset at PHONES jack. Adjust LINE LEVEL and MONITOR AUDIO knobs for usable signal level. Readjust BANDSPREAD knob to obtain desired signal. For a <u>lower</u> sideband transmission, <u>increase</u> BANDSPREAD frequency setting as high as possible to still receive signal on headset. For an <u>upper</u> sideband transmission, <u>decrease</u> BANDSPREAD frequency setting as low as possible to still receive signal. Hold down RF/AF button and adjust ANT TUNE knob to obtain maximum reading on meter. Release button. LINE LEVEL knob fully ccw.
11	SBS-I-1	POWER switch to ON. STANDBY lamps will go out. POWER ON lamp will light and SBS-I-1 blower will start. AFC switch to OFF. CHANNEL A LEVEL ADJUST knob to mid-position. CHANNEL B LEVEL ADJUST knob fully ccw. CHANNEL A IF BANDWIDTH KC switch to 3.5L, 7.5L, 7.5U or 3.5U, depending on which sideband is being transmitted and its width. CHANNEL A DETECTION switch to SSB. AGC SELECTOR switch to A. CHANNEL A AGC RESPONSE switch to SLOW. Insert headset at MONITOR jack and adjust MONITOR GAIN knob to obtain usable volume of signal on headset.

TABLE 3-6. TUNE-UP PROCEDURE FOR SSB WITH FULLY SUPPRESSED CARRIER (USING GPR-92, NRC OSCILLATORS AND SBS-I-1 WITH CHANNEL A OUTPUT, DIVERSITY OR NON-DIVERSITY) (Con't)

STEP	MODULE	OPERATION
12	GPR-92	<u>2nd Fine Tuning:</u> - Readjust BANDSPREAD knob to obtain entire sideband (from low to high tones) at headset at SBS-I-1 MONITOR jack. If this is not possible, return BANDSPREAD to previous position and perform step 13; otherwise, proceed to step 14.
13	NRC Type 173 Model 2 Oscillator	Set FREQUENCY LOCK switch to OFF. Readjust LOCKING DIGIT switch positions to new combinations (each time resetting FREQUENCY LOCK switch to ON) until the entire sideband appears on the headset. When entire sideband remains on headset and HIGH and LOW lights have stopped flashing, proceed to step 14.
14	SBS-I-1	Adjust CHANNEL A LEVEL ADJUST knob for proper output level.
15	HSP-3	If speaker output is used, adjust RECEIVER 1 (or RECEIVER 2) VOLUME knob for proper volume.

TABLE 3-7. TUNE-UP PROCEDURE FOR ISB WITH PARTIAL CARRIER* (USING GPR-92, SBS-I-1 AND AFC-2A WITH LSB TO CHANNEL A AND USB TO CHANNEL B, DIVERSITY, OR NON-DIVERSITY)

STEP	MODULE	OPERATION
1	HSP-3	AGC switch to SEPARATE. Set RECEIVER #1 and #2 SPEAKER CHANNEL SELECTOR switches to OFF.
2	SBS-I-1 & NRC units	POWER switches to STANDBY or OFF.
3	DCP-2	MAIN POWER switch to ON. MAIN POWER lamp will light. SBS-I-1 STANDBY lamp will light. Rack blower will start.
4	GPR-92	<u>Preliminary Settings:</u> - MONITOR AUDIO knob fully CCW. LINE LEVEL knob to mid-position. RF GAIN knob fully CW. TUNING and BANDSPREAD dials will light up. ANT TUNE knob to vertical position. SEND/RECEIVE switch to RECEIVE. INT/EXT switch to INT. NOISE LIMITER knob to OFF. SQUELCH knob fully CCW. AVC/MANUAL switch to MANUAL.
5	GPR-92	<u>Coarse Tuning:</u> - MODE switch to SSB. HFO TRIM knob to 0. BFO PITCH knob to 0. RANGE SELECTOR switch for frequency to be received. TUNING and BANDSPREAD knobs for frequency to be received. IF SELECTIVITY switch to 15 KC.
6	GPR-92	<u>Fine Tuning:</u> - Insert headset at PHONES jack. Adjust LINE LEVEL and MONITOR AUDIO knobs for usable signal level. Adjust BANDSPREAD knob so that both signals can be heard. Set IF SELECTIVITY to .5 KC. Readjust BANDSPREAD knob and turn up LINE LEVEL and MONITOR AUDIO knobs to obtain "beat" note. Again adjust BANDSPREAD knob to eliminate beat note or to bring it to as low a tone as possible. (<u>Note:</u> Beat is produced by carrier and GPR-92 BFO while GPR-92 is detuned). Set IF SELECTIVITY TO 15 KC. Hold down RF/AF

* ISB transmitted with a carrier suppressed no lower than 30 db below PEP.

TABLE 3-7. TUNE-UP PROCEDURE FOR ISB WITH PARTIAL CARRIER* (USING GPR-92, SBS-I-1 AND AFC-2A WITH LSB TO CHANNEL A AND USB TO CHANNEL B, DIVERSITY OR NON-DIVERSITY) (Cont)

STEP	MODULE	OPERATION
6 (Cont)		button and readjust LINE LEVEL knob to obtain usable reading on meter. Then adjust ANT TUNE knob for peak reading on meter. Release button.
7	SBS-I-1	POWER switch to ON. STANDBY lamp will go out. POWER ON lamp will light and SBS-I-1 blower will start. AFC switch to OFF. CHANNEL A and B LEVEL ADJUST knobs to mid-positions. CHANNEL A IF BANDWIDTH KC switch to 3.5L or 6.0L, depending on sideband width. CHANNEL B IF BANDWIDTH KC switch to 3.5U or 6.0U, depending on sideband width. CHANNEL A and B DETECTION switches to SSB. AGC SELECTOR switch to AB. CHANNEL A and B AGC RESPONSE switches to SLOW. Insert headset at MONITOR jack. Adjust MONITOR GAIN knob toward "A" to obtain lower sideband signal on headset; then adjust knob toward "B" to obtain upper sideband signal. Both signals should be complete (including high and low tones); if not, readjust GPR-92 BANDSPREAD knob until both signals come through clearly.
8	AFC-2A	CARRIER SELECTOR switch to OSC. TUNING/KCS knob to 0. SENSITIVITY knob fully CW.
9	SBS-I-1	AFC switch to ON.
10	AFC-2A	Observe LEVEL meter. Hold down RESET button and adjust TUNING/KCS knob to obtain peak reading. Release RESET button. Monitor one of the sidebands at SBS-I-1 MONITOR jack by turning MONITOR GAIN knob toward A or B. Observe DRIFT meter. DRIFT meter needle will remain steady through signal tone variations if AFC-2A is locked on carrier. If needle is not steady, AFC-2A is locked onto a sideband; in this case, repeat step 10 until it locks onto the carrier.

* ISB transmitted with a carrier suppressed no lower than 30 db below PEP

TABLE 3-7. TUNE-UP PROCEDURE FOR ISB WITH PARTIAL CARRIER* (USING GPR-92, SBS-I-1 AND AFC-2A WITH LSB TO CHANNEL A AND USB TO CHANNEL B, DIVERSITY OR NQN-DIVERSITY) (Cont)

STEP	MODULE	OPERATION
11	SBS-I-1	Adjust CHANNEL A and B LEVEL ADJUST knobs for proper output levels.

* ISB transmitted with a carrier suppressed no lower than 30 db below PEP

TABLE 3-8. TUNE-UP PROCEDURE FOR ISB WITH FULLY SUPPRESSED CARRIER (USING GPR-92, NRC OSCILLATORS AND SBS-I-1 WITH LSB TO CHANNEL A AND USB TO CHANNEL B, DIVERSITY OR NON-DIVERSITY)

STEP	MODULE	OPERATION
1		If NRC Type 173 Variable Master Oscillator has been previously placed in standby condition (see paragraph 3-2 c (4)), do not perform step 2 but proceed with step 3. If the Oscillator has not been placed in standby, perform step 2.
2	DCP-2	MAIN POWER switch to ON. MAIN POWER lamp will light. Rack blower will start. After 20 minutes, NRC Type 173 Variable Master Oscillator XTAL OVEN lamps will start to cycle. Wait 18 hours for oven stabilization before proceeding with step 8.
3	HSP-3	AGC switch to SEPARATE. Set RECEIVER #1 and #2 SPEAKER CHANNEL SELECTOR switches to OFF.
4	SBS-I-1	POWER switch to STANDBY. STANDBY lamp will light.
5	GPR-92	<u>Preliminary Settings:</u> - MONITOR AUDIO knob fully ccw. LINE LEVEL knob to mid-position. RF GAIN knob fully cw. TUNING and BANDSPREAD dials will light up. ANT TUNE knob to vertical position. SEND/RECEIVE switch to RECEIVE. INT/EXT switch to EXT. NOISE LIMITER knob to OFF. LIMITER switch to OFF. SQUELCH knob fully ccw. AVC/MANUAL switch to MANUAL.
6	GPR-92	<u>Coarse Tuning:</u> - MODE switch to SSB. RANGE SELECTOR switch for frequency of suppressed carrier (F_c). IF SELECTIVITY switch to 7.5KC (for 2 3-kc sidebands) or 15KC (for 2 6-kc sidebands). TUNING and BANDSPREAD knobs for F_c .

TABLE 3-8. TUNE-UP PROCEDURE FOR ISB WITH FULLY SUPPRESSED CARRIER (USING GPR-92, NRC OSCILLATORS AND SBS-I-1 WITH LSB TO CHANNEL A AND USB TO CHANNEL B, DIVERSITY OR NON-DIVERSITY) (Con't)

STEP	MODULE	OPERATION
7	NRC Type 108, Model 2 Oscillator	POWER switch to ON. POWER lamp and 1 and 2 OVEN HEATER lamps will light. BFO switch to ON. HFO switch to ON. HFO CRYSTAL switch to EXT. Calculate HFO frequency on the basis of F_c (suppressed carrier frequency)*. Set OUTPUT FREQUENCY knob and HFO MULTIPLIER knob to produce HFO frequency as a product. (Example: for HFO of 8.553,285 mc, set OUTPUT FREQUENCY knob to 2.13 and HFO MULTIPLIER knob to X4 position.) BFO CRYSTAL switch to 1. HFO OUTPUT knob at mid-position.
8	NRC Type 173, Model 2, Oscillator Power Supply	POWER switch to ON. POWER lamp will light.
9	NRC Type 173, Model 2 Oscillator	FREQ LOCK switch to OFF. OUTPUT switch to OFF. BFO CRYSTAL switch (on chassis rear) to 1. MAIN TUNING knob to bring <u>HFO frequency</u> M** on display counters (to within 400 cycles maximum). Set 3 LOCKING DIGITS switches on the numbers for the last 3 digits of the <u>HFO</u> frequency. FREQUENCY LOCK switch to ON. Wait for oscillator to "pull" to correct frequency as indicated by digits appearing on last 3 columns of digit display and flashing

* HFO frequency to equal $F_c + 455\text{kc}$ (when $F_c = 0.54\text{- to } 5.6\text{-mc}$) or $F_c + 3,955\text{kc}$ (when $F_c = 5.6\text{- to } 32.3\text{-mc}$)

** M is FREQUENCY MULTIPLIER knob setting multiplication factor (1, 2, 4 or 8) from step 7.

TABLE 3-8. TUNE-UP PROCEDURE FOR ISB WITH FULLY SUPPRESSED CARRIER (USING GPR-92, NRC OSCILLATORS AND SBS-I-1 WITH LSB TO CHANNEL A AND USB TO CHANNEL B, DIVERSITY OR NON-DIVERSITY) (Con't)

STEP	MODULE	OPERATION
9 (Con't)		HIGH and LOW lights. When digits appear correctly and HIGH and LOW lights have stopped flashing, observe CORRECTION STRENGTH meter. If oven has stabilized properly, meter will read in NORMAL RANGE. OUTPUT switch to ON. OUTPUT lamp will light.
10	GPR-92	<u>Fine Tuning:</u> - Insert headset at PHONES jack. Adjust LINE LEVEL and MONITOR AUDIO knobs for usable signal level. Adjust BANDSPREAD knob so that both signals can be heard. Hold down RF/AF button and adjust ANT TUNE knob for peak reading on meter. Release button.
11	SBS-I-1	POWER switch to ON. STANDBY lamp will go out. POWER ON lamp will light and SBS-I-1 blower will start. AFC switch to OFF. CHANNEL A and B LEVEL ADJUST knobs to mid-positions. CHANNEL A IF BANDWIDTH KC switch to 3.5L or 6.0L, depending on sideband width. CHANNEL B IF BANDWIDTH KC switch to 3.5U or 6.0U, depending on sideband width. CHANNEL A and B DETECTION switches to SSB. AGC SELECTOR switch to AB. CHANNEL A and B AGC RESPONSE switches to SLOW; Insert headset at MONITOR jack. Adjust MONITOR GAIN knob toward "A" to obtain lower sideband signal on headset; then adjust knob toward "B" to obtain upper sideband signal. Both signals should be complete (including high and low tones); if not, readjust GPR-92 BANDSPREAD knob until both signals come through clearly. Adjust CHANNEL A and B LEVEL ADJUST knobs for proper output levels.

TABLE 3-9. TUNE-UP PROCEDURE FOR AM (SSB RECEPTION,
USING GPR-92, SBS-I-1 AND AFC-2A WITH
CHANNEL A OUTPUT, DIVERSITY OR NON-DIVERSITY)

STEP	MODULE	OPERATION
1	HSP-3	AGC switch to SEPARATE. If speaker is to be used, set RECEIVER #1 (or #2) SPEAKER CHANNEL SELECTOR switch to A. Other SPEAKER CHANNEL SELECTOR switch to OFF.
2	SBS-I-1 & NRC units	POWER switches to STANDBY or OFF.
3	DCP-2	MAIN POWER switch to ON. MAIN POWER lamp will light. SBS-I-1 STANDBY lamp will light. Rack blower will start.
4	GPR-92	Preliminary Settings: - MONITOR AUDIO knob fully CCW. LINE LEVEL knob to mid-position. RF GAIN knob fully CW. TUNING and BANDSPREAD dials will light up. ANT TUNE knob to vertical position. SEND/RECEIVE switch to RECEIVE. INT/EXT switch to INT. NOISE LIMITER knob to OFF. SQUELCH knob fully CCW. AVC/MANUAL switch to MANUAL.
5	GPR-92	Coarse Tuning: - MODE switch to AM. HFO TRIM knob to 0. RANGE SELECTOR switch for frequency to be received. TUNING and BANDSPREAD knobs for frequency to be received. IF SELECTIVITY switch to 7.5 KC.
6	GPR-92	Fine Tuning: - Insert headset at PHONES jack. Adjust LINE LEVEL and MONITOR AUDIO knobs for usable signal level. Readjust BANDSPREAD knob to obtain desired signal. Hold down RF/AF button and adjust ANT TUNE knob for peak reading on meter. Release button. LINE LEVEL knob fully CCW. AVC/MANUAL switch to AVC.
7	SBS-I-1	POWER switch to ON. STANDBY lamp will go out. POWER ON lamp will light and SBS-I-1 blower will start. AFC switch to OFF. CHANNEL A LEVEL ADJUST knob fully CW. CHANNEL B LEVEL ADJUST knob fully CCW. CHANNEL A IF BANDWIDTH KC switch to 3.5L. CHANNEL A DETECTION switch to SSB. AGC SELECTOR switch to A. CHANNEL A

(Cont'd)

TABLE 3-9. TUNE-UP PROCEDURE FOR AM (SSB RECEPTION, USING GPR-92, SBS-I-1 AND AFC-2A WITH CHANNEL A OUTPUT, DIVERSITY OR NON-DIVERSITY) (Cont)

STEP	MODULE	OPERATION
7 (Cont)		AGC RESPONSE switch to SLOW Insert headset at MONITOR jack and adjust MONITOR GAIN knob toward "A" to obtain usable volume of signal on headset.
8	AFC-2A	CARRIER SELECTOR switch to OSC. TUNING/KCS knob to 0. SENSITIVITY knob fully CW.
9	SBS-I-1	AFC switch to ON.
10	AFC-2A	Observe LEVEL meter. Hold down RESET button and adjust TUNING/KCS knob to obtain peak reading. Release RESET button. Monitor signal with headset at SBS-I-1 MONITOR jack. Observe DRIFT meter. DRIFT meter needle will remain steady through signal tone variations if AFC-2A is locked on carrier. If needle is not steady, AFC-2A is locked on the sideband; in this case, repeat step 10 until it locks onto carrier.
11	SBS-I-1	Set CHANNEL A IF BANDWIDTH KC switch to 3.5U and compare signal at headset with 3.5L setting. Select best signal. Adjust CHANNEL A LEVEL ADJUST knob for proper output level.
12	HSP-3	If speaker output is used, adjust RECEIVER 1 (or RECEIVER 2) VOLUME knob for proper volume.

TABLE 3-10. TUNE-UP PROCEDURE FOR FSK (USING GPR-92, NRC OSCILLATORS AND SBS-I-1, WITH CHANNEL A OUTPUT, DIVERSITY OR NON-DIVERSITY)

STEP	MODULE	OPERATION
1		If NRC Type 173 Variable Master Oscillator has been previously placed in standby condition (see paragraph 3-2 c (4), do not perform step 2 but proceed with step 3. If the Oscillator has not been placed in standby, perform step 2.
2	DCP-2	MAIN POWER switch to ON. MAIN POWER lamp will light. Rack blower will start. After 20 minutes, NRC Type 173 Variable Master Oscillator XTAL OVEN lamp will start to cycle. Wait 18 hours for oven stabilization before proceeding with step 9.
3	HSP-3	AGC switch to SEPARATE. RECEIVER #1 and #2 SPEAKER CHANNEL SELECTOR switches to OFF.
4	SBS-I-1	POWER switch to STANDBY. STANDBY lamp will light.
5	GPR-92	<u>Preliminary Settings:</u> - MONITOR AUDIO knob fully ccw. LINE LEVEL knob to mid-position. RF GAIN knob fully cw. TUNING and BANDSPREAD dials will light up. ANT TUNE knob to vertical position. SEND/RECEIVE switch to RECEIVE. INT/EXT switch to EXT. NOISE LIMITER knob to OFF. LIMITER switch to OFF. SQUELCH knob fully ccw. AVC/MANUAL switch to MANUAL.
6	GPR-92	<u>Coarse Tuning:</u> - MODE switch to CW. RANGE SELECTOR switch for center frequency. IF SELECTIVITY switch for frequency shift. TUNING and BANDSPREAD knobs for center frequency.

TABLE 3-10. TUNE-UP PROCEDURE FOR FSK (USING GPR-92, NRC OSCILLATORS AND SBS-I-1, WITH CHANNEL A OUTPUT, DIVERSITY OR NON-DIVERSITY) (Con't)

STEP	MODULE	OPERATION
7	NRC Type 108, Model 2 Oscillator	POWER switch to ON. POWER lamp and 1 and 2 OVEN HEATER lamps will light. BFO switch to ON. HFO switch to ON. HFO CRYSTAL switch to EXT. Calculate HFO frequency on the basis of F_c (r-f input center frequency) and F_{ac} (audio output center frequency) as described in paragraph 3-2 c (2). Set OUTPUT FREQUENCY knob and HFO MULTIPLIER knob to produce HFO frequency as a product. (Example: for HFO of 8.553,285 mc, set OUTPUT FREQUENCY knob to 2.13 and HFO MULTIPLIER knob to X4 position.) BFO CRYSTAL switch to 1. HFO OUTPUT knob at mid-position.
8	NRC Type 173, Oscillator Power Supply	POWER switch to ON. POWER lamp will light.
9	NRC Type 173, Model 2 Oscillator	FREQ LOCK switch to OFF. OUTPUT switch to OFF. BFO CRYSTAL switch (on chassis rear) to 1. MAIN TUNING knob to bring $\frac{HFO \text{ frequency}}{M^*}$ on display counters (to within 400 cycles maximum). Set 3 LOCKING DIGITS switches on the numbers for the last 3 digits of the $\frac{HFO \text{ frequency}}{M}$. FREQUENCY LOCK switch to ON. Wait for oscillator to "pull" to correct frequency as indicated by digits appearing on last 3 columns of digit display and flashing HIGH and LOW lights. When digits appear correctly and HIGH and LOW lights have stopped flashing, observe

* M is FREQUENCY MULTIPLIER knob setting multiplication factor (1, 2, 4 or 8) from step 7.

TABLE 3-10. TUNE-UP PROCEDURE FOR FSK (USING GPR-92, NRC OSCILLATORS AND SBS-I-1, WITH CHANNEL A OUTPUT, DIVERSITY OR NON-DIVERSITY) (Con't)

STEP	MODULE	OPERATION
9 (Con't)		CORRECTION STRENGTH meter. If oven has stabilized properly, meter will read in NORMAL RANGE. OUTPUT switch to ON. OUTPUT lamp will light.
10	GPR-92	<u>Fine Tuning:</u> - Insert headset at PHONES jack. Adjust LINE LEVEL and MONITOR AUDIO knobs for usable signal level. Readjust BANDSPREAD knob to obtain the mark and space audio tones on the headset. Hold down RF/AF button and adjust ANT TUNE knob for peak reading on meter. Release button.
11	SBS-I-1	POWER switch to ON. STANDBY lamp will go out. POWER ON lamp will light and SBS-I-1 blower will start. AFC switch to OFF. CHANNEL A LEVEL ADJUST knob to mid-position. CHANNEL B LEVEL ADJUST knob fully ccw. CHANNEL A IF BANDWIDTH KC switch to position determined by calculation of HFO per step 7 and paragraph 3-2 c (2). CHANNEL A DETECTION switch to cw. AGC SELECTOR switch to A. CHANNEL A AGC RESPONSE switch to SLOW. Insert headset at MONITOR jack and adjust MONITOR GAIN knob to obtain usable volume of mark and space tones on headset. Adjust CHANNEL A LEVEL ADJUST knob for proper output level to drive teletype equipment.
12	NRC Type 173, Model 2 Oscillator	Using headset at SBS-I-1 as a monitor, observe teletype equipment. If mark and space test signal appears in headset but teletype equipment does not operate, the transmitted frequencies may be off slightly. In this case, the Variable Oscillator may be altered slightly to compensate for the error as follows. Observe present frequency

TABLE 3-10. TUNE-UP PROCEDURE FOR FSK (USING GPR-92, NRC OSCILLATORS AND SBS-I-1, WITH CHANNEL A OUTPUT, DIVERSITY OR NON-DIVERSITY) (Con't)

STEP	MODULE	OPERATION
12 (Con't)		<p>reading on GPR-92 TUNING and BAND-SPREAD dials and compare with F_c (r-f center frequency) nominal value in planned transmission. If dial settings appear higher than nominal F_c, Type 173 Oscillator must be set higher; if dial settings are lower, the Oscillator must be set lower. Keep in mind that each frequency change at Type 173 Oscillator is multiplied by the Type 108 Oscillator as appears at its HFO MULTIPLIER switch setting. To adjust Type 173 Oscillator, proceed as follows. Set FREQUENCY LOCK switch to OFF. Readjust LOCKING DIGITS switch positions to new combinations (each time resetting FREQUENCY LOCK switch to ON) until teletype equipment starts to operate. Use headset at SBS-I-1 to ensure that tones are not lost in the process. When HIGH and LOW lights have stopped flashing, CORRECTION STRENGTH meter reads in NORMAL RANGE and teletype equipment continues to operate, the Oscillator has been adjusted correctly.</p>
13	GPR-92	<p>Set IF SELECTIVITY switch to smallest value that will still give clear, strong signal results at teletype equipment. This will depend on input frequency characteristics of the frequency shift converter being used.</p>
14	SBS-I-1	<p>Adjust CHANNEL A LEVEL ADJUST knob for proper output level to operate frequency shift converter.</p>

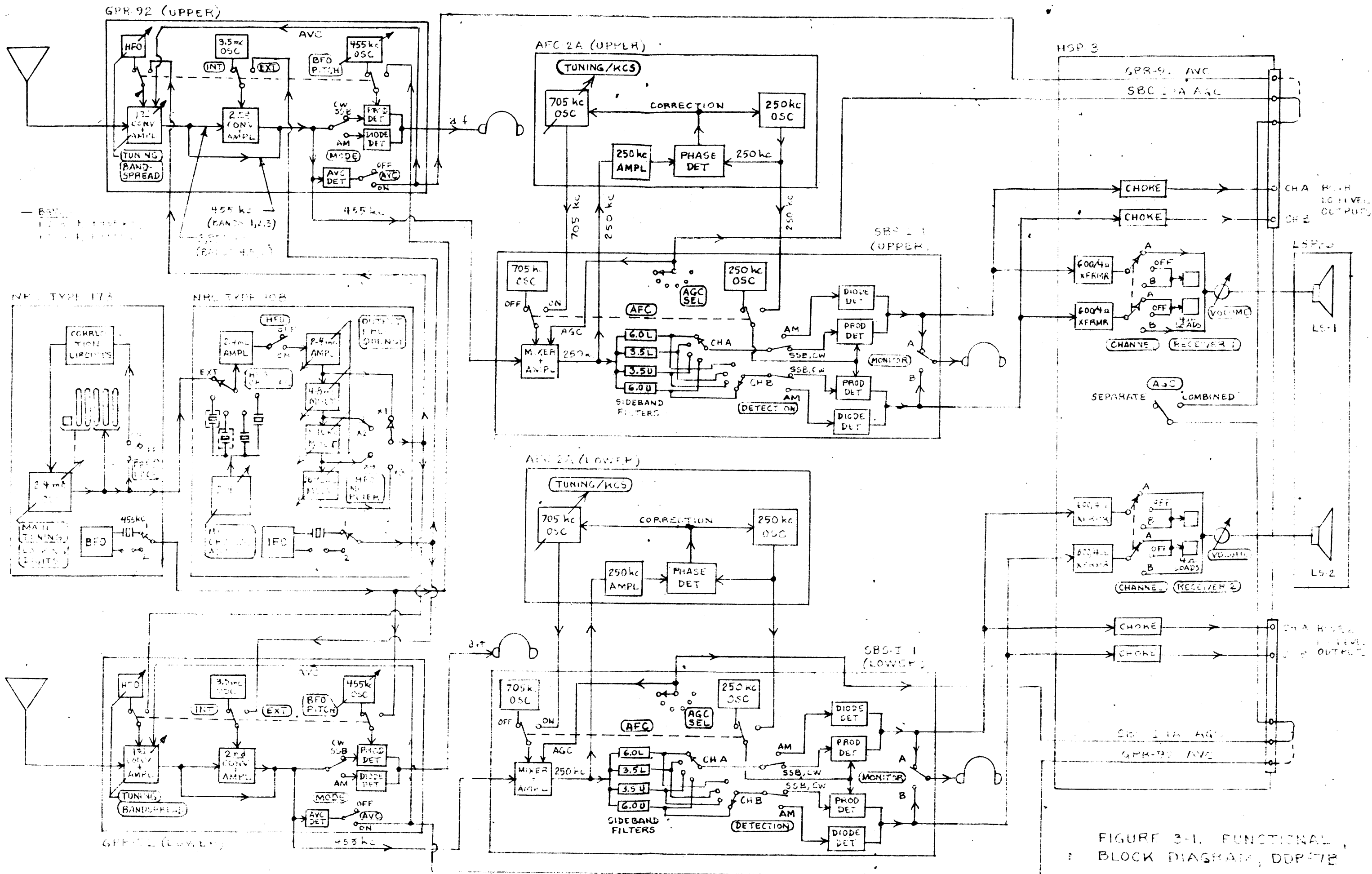

FIGURE 3-1. FUNCTIONAL BLOCK DIAGRAM, DDP-7E

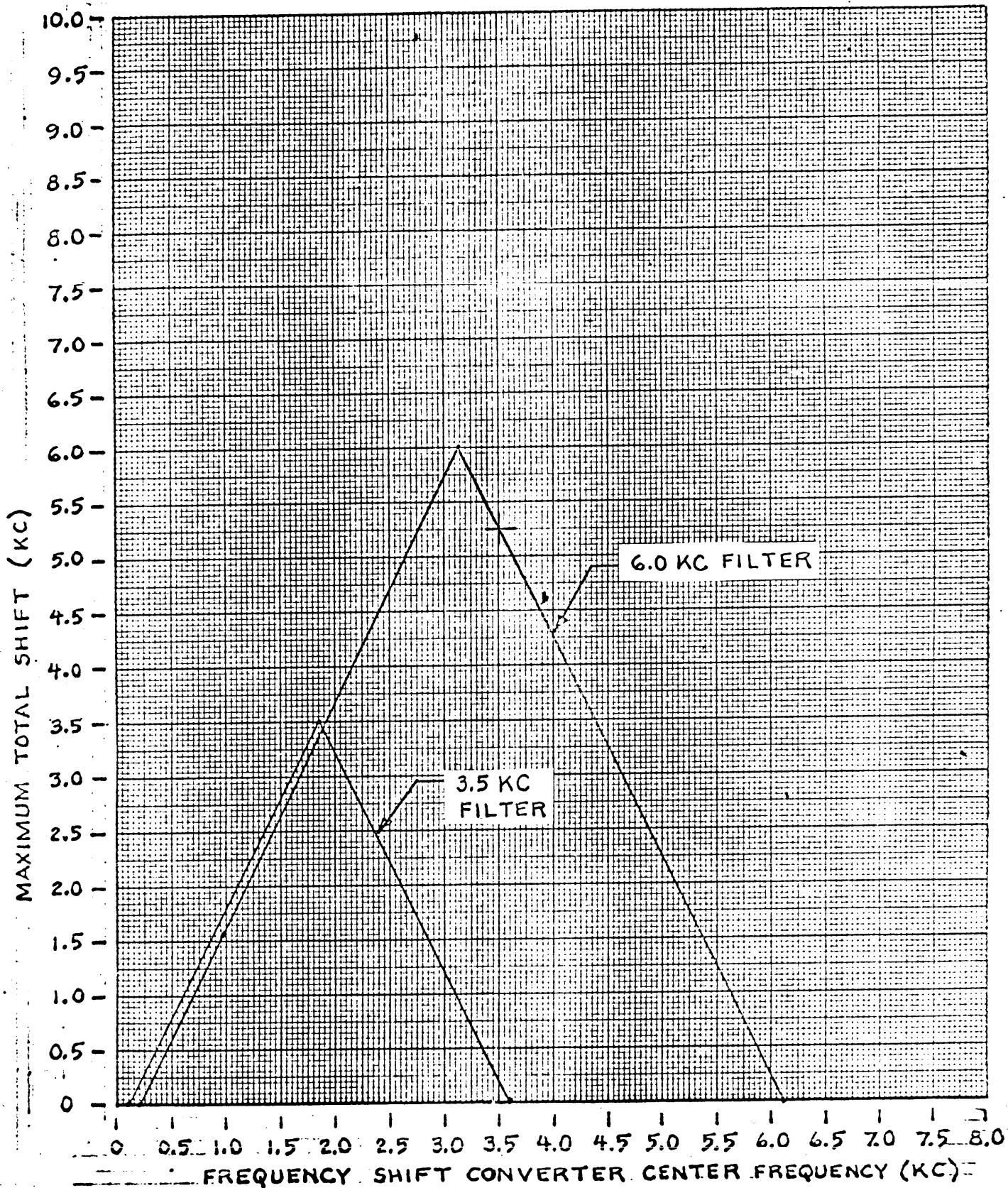

FIGURE 3-2. FSK CONVERTER CENTER FREQUENCY VS. DDR-7 B SHIFT CAPABILITIES

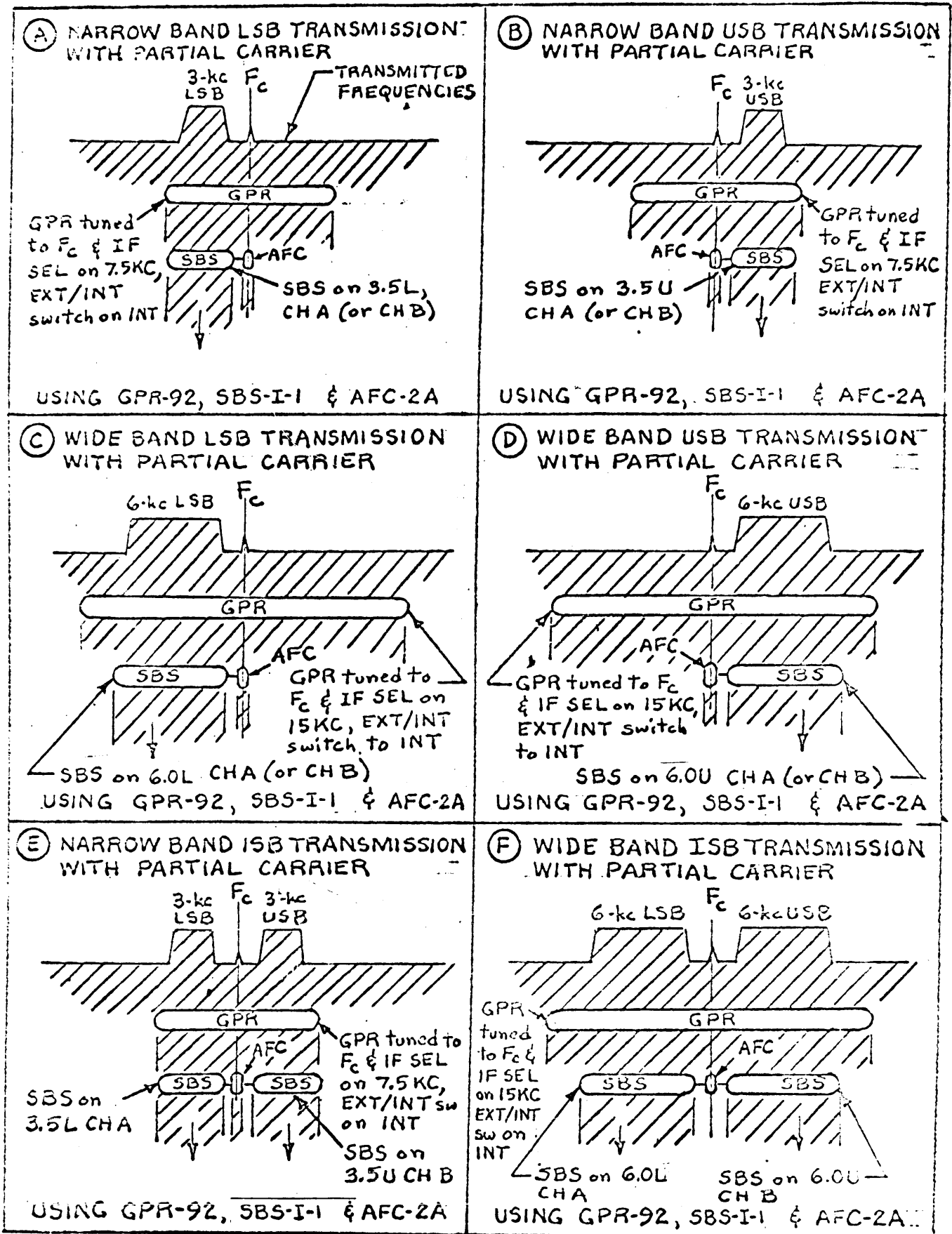
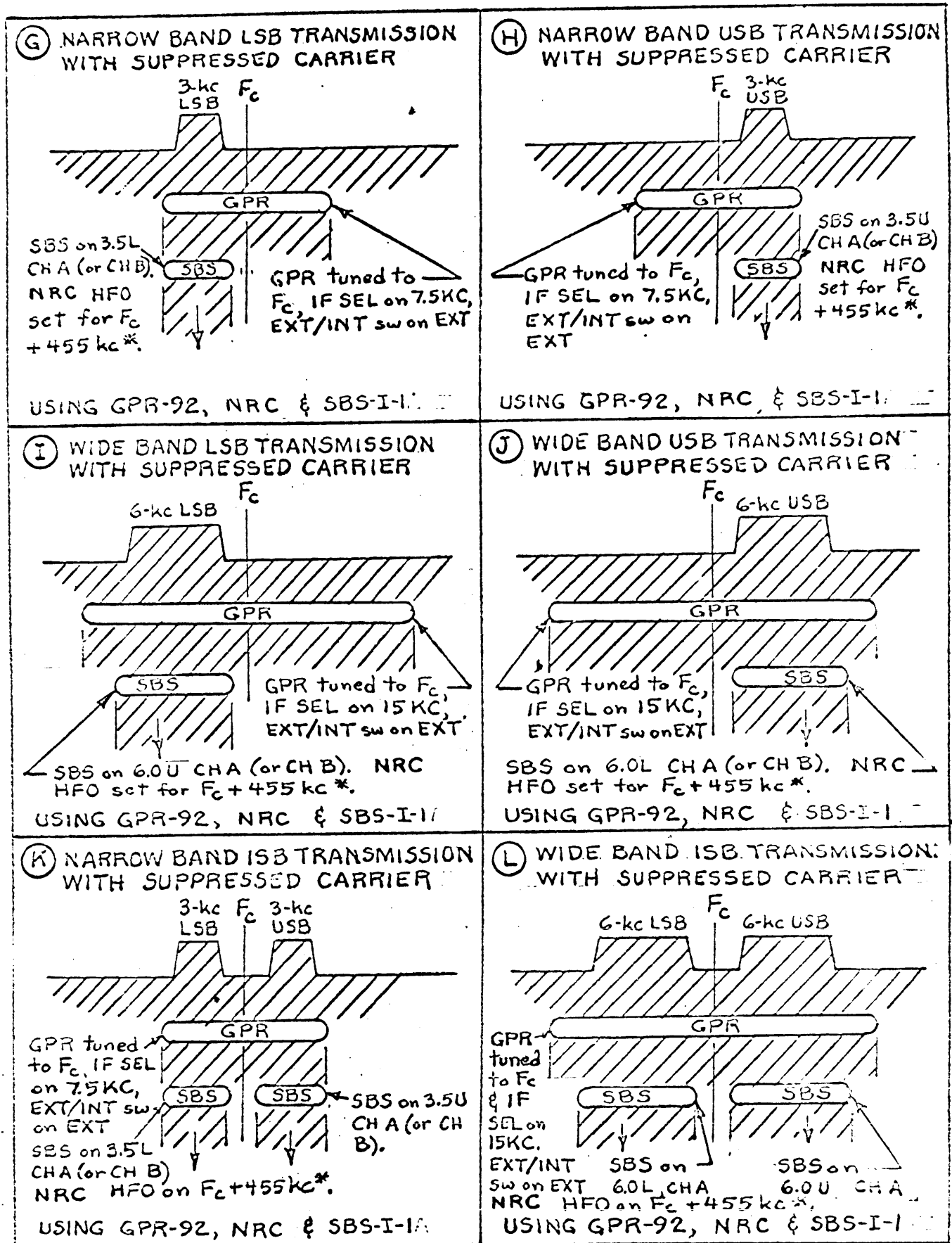

FIGURE 3-3. SLOT TUNING DIAGRAMS, DDR-7B (SHEET 1 OF 5)



* $F_c + 455 \text{ kc}$ when $F_c = .54 \text{ mc}$ to 5.6 mc . $F_c + 3,955 \text{ kc}$ when $F_c = 5.6 \text{ mc}$ to 32.3 mc

FIGURE 3-3. SLOT TUNING DIAGRAMS, DDR-7B (SHEET 2 OF 5)

(M) NARROW BAND AM TRANSMISSION (LSB RECEPTION)

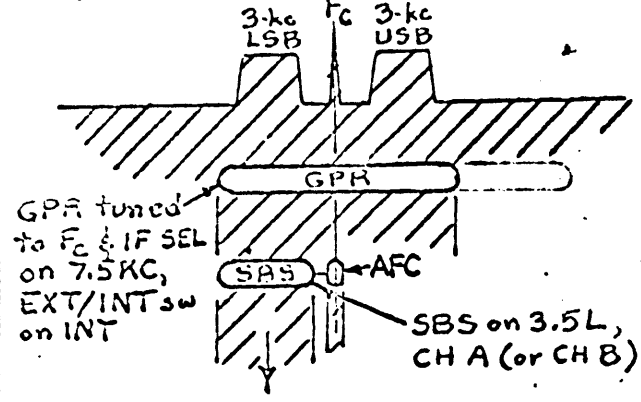

USING GPR-92, SBS-I-1A & AFC-2A

(N) NARROW BAND AM TRANSMISSION (USB RECEPTION)

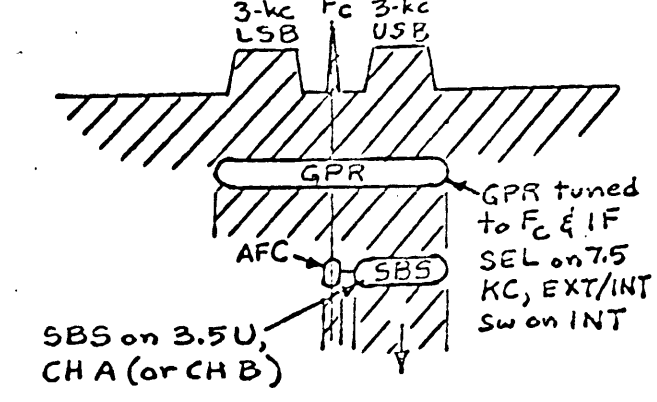

USING GPR-92, SBS-I-1 & AFC-2A

(O) WIDE BAND AM TRANSMISSION (LSB RECEPTION)

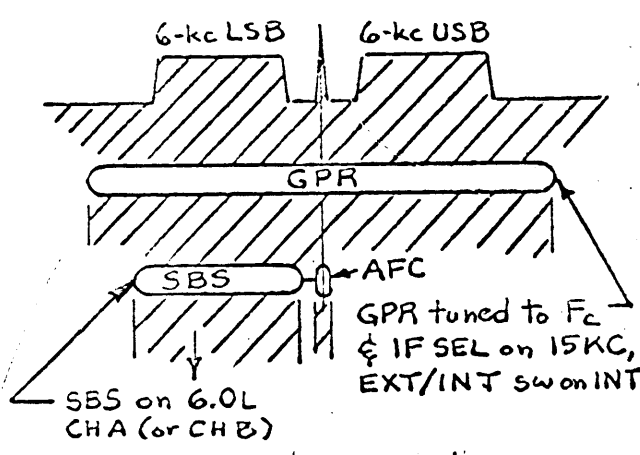

USING GPR-92, SBS-I-1A & AFC-2A

(P) WIDE BAND AM TRANSMISSION (USB RECEPTION)

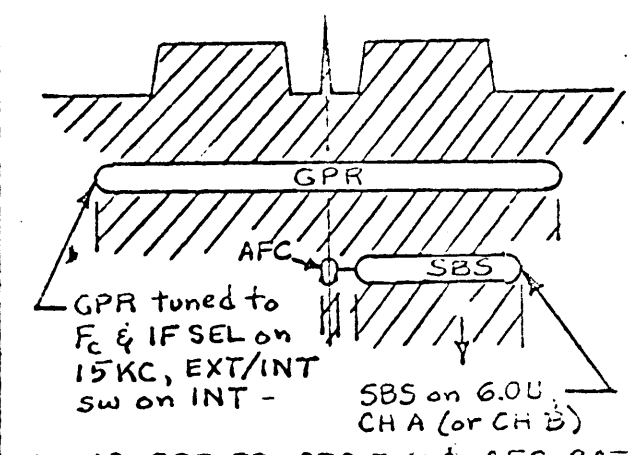

USING GPR-92, SBS-I-1 & AFC-2A

(Q) WEAK NARROW BAND AM TRANSMISSION (LSB RECEPTION)

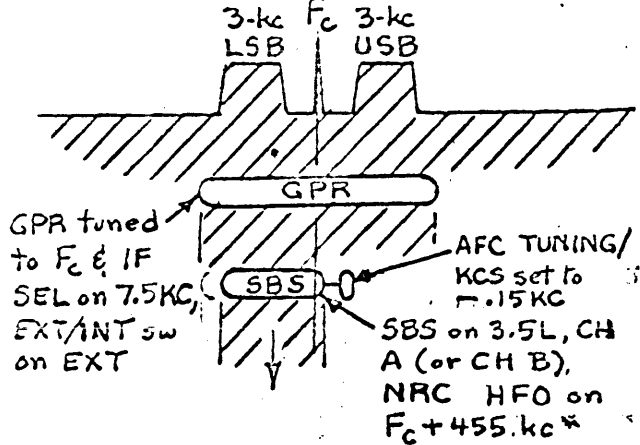

USING GPR-92, NRC & SBS-I-1

(R) WEAK NARROW BAND AM TRANSMISSION (USB RECEPTION)

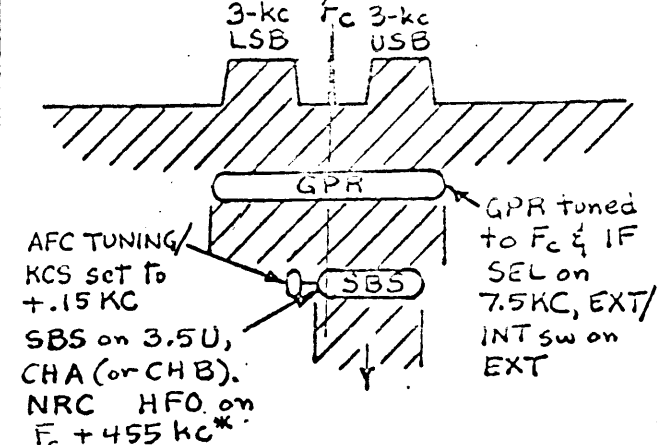

USING GPR-92, NRC & SBS-I-1

* $F_c + 455$ kc when $F_c = 5.4$ mc. to 5.6 mc. $F_c + 3,955$ kc when $F_c = 5.6$ mc. to 32.3 mc.

FIGURE 3-3. SLOT TUNING DIAGRAMS, DDR-7B (SHEET 3 OF 5)

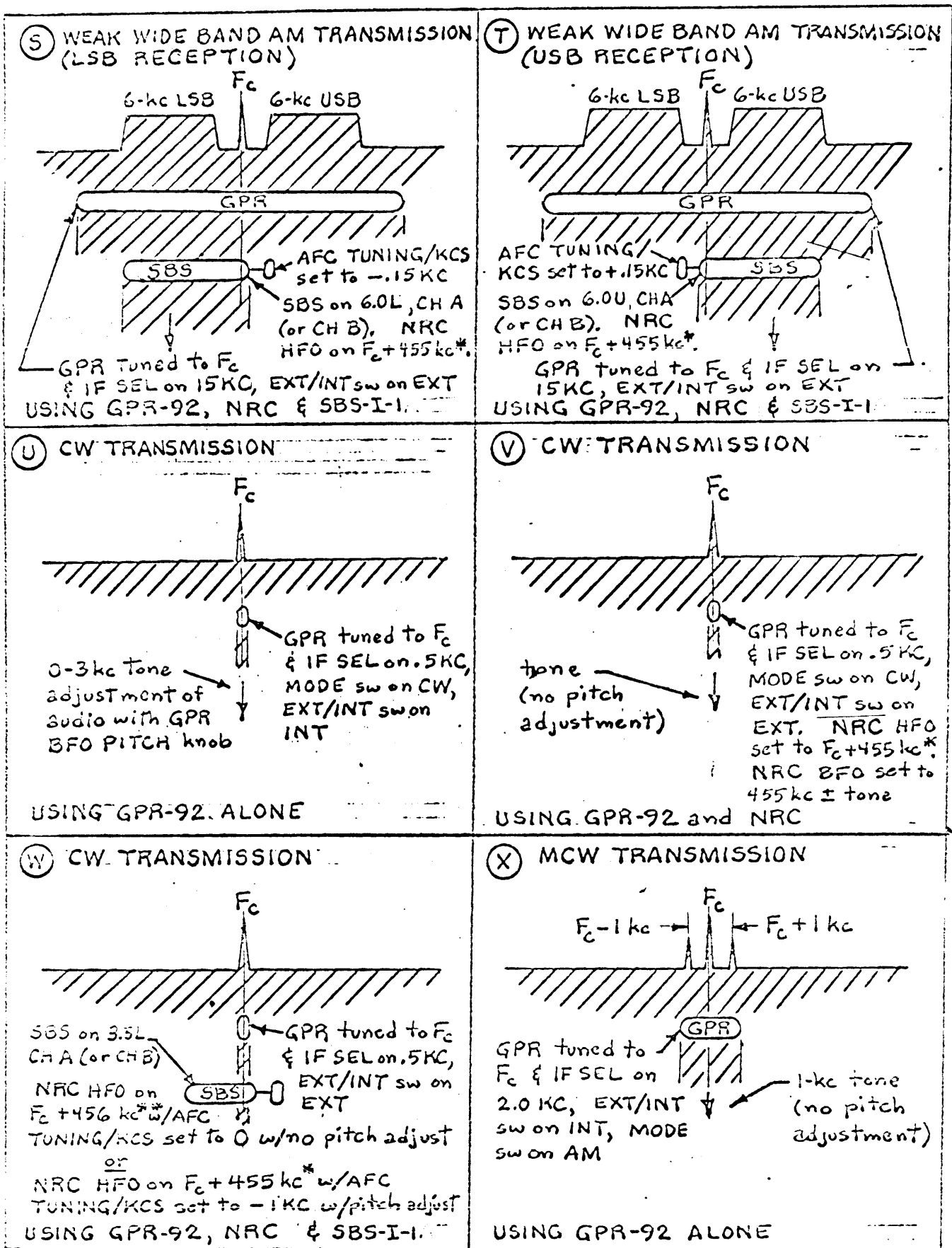

* $F_c + 455$ kc when $F_c = .54$ mc to 5.6 mc. $F_c + 3,955$ kc when $F_c = 5.6$ mc to 32.3 mc
 ** $F_c + 456$ kc when $F_c = .54$ mc to 5.6 mc. $F_c + 3,956$ kc when $F_c = 5.6$ mc to 32.3 mc

FIGURE 3-3. SLOT TUNING DIAGRAMS, DDR-7B (SHEET 4 OF 5)

Y MCW TRANSMISSION

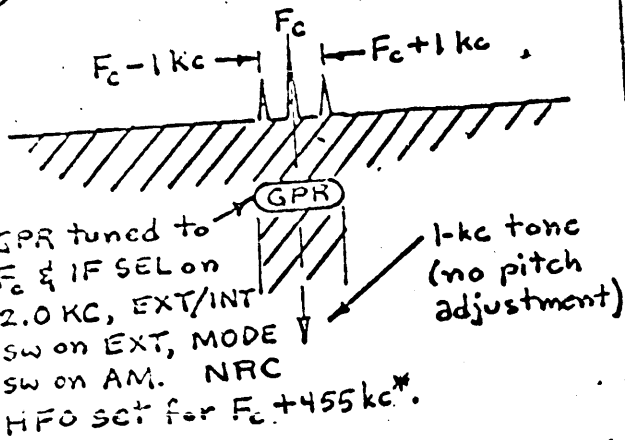

GPR tuned to F_c & IF SEL on 2.0 KC, EXT/INT sw on EXT, MODE sw on AM. NRC HFO set for $F_c + 455 \text{ kc}^*$.
 1-kc tone (no pitch adjustment)
 USING GPR-92 and NRC

Z MCW TRANSMISSION

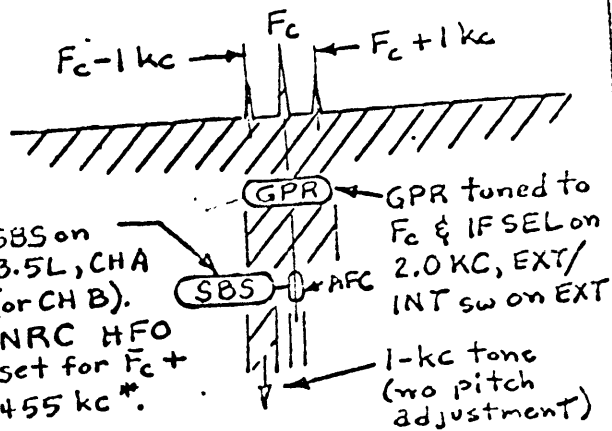

SBS on 3.5L, CHA (or CH B). NRC HFO set for $F_c + 455 \text{ kc}^*$.
 GPR tuned to F_c & IF SEL on 2.0 KC, EXT/INT sw on EXT
 1-kc tone (no pitch adjustment)
 USING GPR-92, NRC, SBS-I-1 & AFC-2A

AA MCW TRANSMISSION

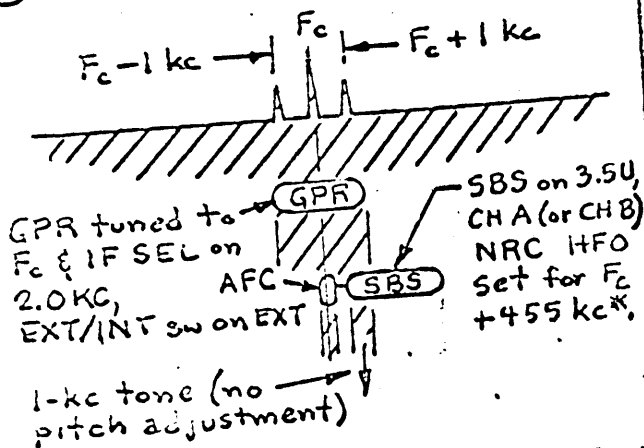

GPR tuned to F_c & IF SEL on 2.0 KC, EXT/INT sw on EXT
 SBS on 3.5L, CHA (or CH B) NRC HFO set for $F_c + 455 \text{ kc}^*$.
 1-kc tone (no pitch adjustment)
 USING GPR-92, NRC, SBS-I-1 & AFC-2A

AB FSK TRANSMISSION (with 850 cps shift and 2550 cps converter center frequency)

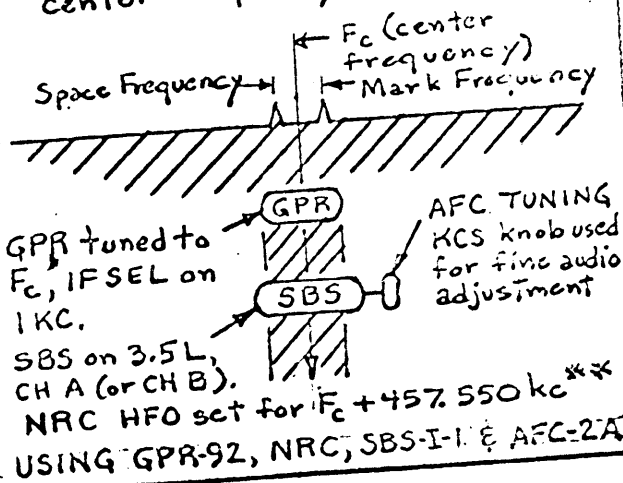

Space Frequency
 F_c (center frequency)
 Mark Frequency
 GPR tuned to F_c , IF SEL on 1 KC.
 SBS on 3.5L, CH A (or CH B). NRC HFO set for $F_c + 457.550 \text{ kc}^{**}$
 AFC TUNING KCS knob used for fine audio adjustment
 USING GPR-92, NRC, SBS-I-1 & AFC-2A

* $F_c + 455 \text{ kc}$ when $F_c = .54 \text{ mc}$ to 5.6 mc . $F_c + 3,955 \text{ kc}$ when $F_c = 5.6 \text{ mc}$ to 32.3 mc
 ** $F_c + 457.550 \text{ kc}$ when $F_c = .54 \text{ mc}$ to 5.6 mc . $F_c + 3,957.550 \text{ kc}$ when $F_c = 5.6 \text{ mc}$ to 32.3 mc