

★
UNCLASSIFIED

INSTALLATION MANUAL
for
GENERAL PURPOSE TRANSMITTER
MODEL GPT-10KR



THE TECHNICAL MATERIEL CORPORATION
MAMARONECK, N.Y. OTTAWA, ONTARIO

★

NOTICE

THE CONTENTS AND INFORMATION CONTAINED IN THIS INSTRUCTION MANUAL IS PROPRIETARY TO THE TECHNICAL MATERIEL CORPORATION TO BE USED AS A GUIDE TO THE OPERATION AND MAINTENANCE OF THE EQUIPMENT FOR WHICH THE MANUAL IS ISSUED AND MAY NOT BE DUPLICATED EITHER IN WHOLE OR IN PART BY ANY MEANS WHATSOEVER WITHOUT THE WRITTEN CONSENT OF THE TECHNICAL MATERIEL CORPORATION.

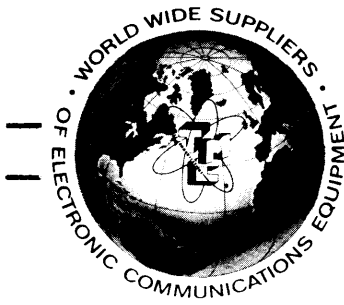

THE TECHNICAL MATERIEL CORPORATION

C O M M U N I C A T I O N S E N G I N E E R S

700 FENIMORE ROAD

MAMARONECK, N. Y.

W a r r a n t y

The Technical Materiel Corporation, hereinafter referred to as TMC, warrants the equipment (except electron tubes,*fuses, lamps, batteries and articles made of glass or other fragile or other expendable materials) purchased hereunder to be free from defect in materials and workmanship under normal use and service, when used for the purposes for which the same is designed, for a period of one year from the date of delivery F.O.B. factory. TMC further warrants that the equipment will perform in a manner equal to or better than published technical specifications as amended by any additions or corrections thereto accompanying the formal equipment offer.

TMC will replace or repair any such defective items, F.O.B. factory, which may fail within the stated warranty period, PROVIDED:

1. That any claim of defect under this warranty is made within sixty (60) days after discovery thereof and that inspection by TMC, if required, indicates the validity of such claim to TMC's satisfaction.
2. That the defect is not the result of damage incurred in shipment from or to the factory.
3. That the equipment has not been altered in any way either as to design or use whether by replacement parts not supplied or approved by TMC, or otherwise.
4. That any equipment or accessories furnished but not manufactured by TMC, or not of TMC design shall be subject only to such adjustments as TMC may obtain from the supplier thereof.

Electron tubes*furnished by TMC, but manufactured by others, bear only the warranty given by such other manufacturers. Electron tube warranty claims should be made directly to the manufacturer of such tubes.

TMC's obligation under this warranty is limited to the repair or replacement of defective parts with the exceptions noted above.

At TMC's option any defective part or equipment which fails within the warranty period shall be returned to TMC's factory for inspection, properly packed with shipping charges prepaid. No parts or equipment shall be returned to TMC, unless a return authorization is issued by TMC.

No warranties, express or implied, other than those specifically set forth herein shall be applicable to any equipment manufactured or furnished by TMC and the foregoing warranty shall constitute the Buyers sole right and remedy. In no event does TMC assume any liability for consequential damages, or for loss, damage or expense directly or indirectly arising from the use of TMC Products, or any inability to use them either separately or in combination with other equipment or materials or from any other cause.

*Electron tubes also include semi-conductor devices.

PROCEDURE FOR RETURN OF MATERIAL OR EQUIPMENT

Should it be necessary to return equipment or material for repair or replacement, whether within warranty or otherwise, a return authorization must be obtained from TMC prior to shipment. The request for return authorization should include the following information:

1. Model Number of Equipment.
2. Serial Number of Equipment.
3. TMC Part Number.
4. Nature of defect or cause of failure.
5. The contract or purchase order under which equipment was delivered.

PROCEDURE FOR ORDERING REPLACEMENT PARTS

When ordering replacement parts, the following information must be included in the order as applicable:

1. Quantity Required.
2. TMC Part Number.
3. Equipment in which used by TMC or Military Model Number.
4. Brief Description of the Item.
5. The *Crystal Frequency* if the order includes crystals.

PROCEDURE IN THE EVENT OF DAMAGE INCURRED IN SHIPMENT

TMC's Warranty specifically excludes damage incurred in shipment to or from the factory. In the event equipment is received in damaged condition, the carrier should be notified immediately. Claims for such damage should be filed with the carrier involved and not with TMC.

All correspondence pertaining to Warranty Claims, return, repair, or replacement and all material or equipment returned for repair or replacement, within Warranty or otherwise, should be addressed as follows:

THE TECHNICAL MATERIEL CORPORATION
Engineering Services Department
700 Fenimore Road
Mamaroneck, New York

TABLE OF CONTENTS

Section		Page
	CHAPTER 1. GENERAL INFORMATION	
1-1	Scope - - - - -	1-1
1-2	Purpose and Description - - - - -	1-1
1-3	Leading Particulars - - - - -	1-4
1-4	Capabilities and Limitations - - - - -	1-7
1-5	Equipment Supplied - - - - -	1-9
1-6	Equipment Required But Not Supplied - - - - -	1-24
1-7	Associated Manuals - - - - -	1-25
	CHAPTER 2. INSTALLATION	
2-1	Introduction - - - - -	2-1
I	PRE-INSTALLATION	
2-2	Scope - - - - -	2-1
2-3	Environment - - - - -	2-1
2-4	Location of Peripheral Equipment - - - - -	2-1
2-5	Ac Input Power Requirements - - - - -	2-2
2-6	Station Ground - - - - -	2-4
2-7	Equipment Anchoring - - - - -	2-4
2-8	Antenna Transmission Line - - - - -	2-4
2-9	Peripheral Air Conditioning - - - - -	2-5
2-10	Dimensional Clearances - - - - -	2-5
2-11	Transmitter Location - - - - -	2-6

TABLE OF CONTENTS

Section		Page
CHAPTER 2. INSTALLATION (cont)		
II	LOGISTICS	
	2-12 Scope - - - - -	2-11
	2-13 Material Handling - - - - -	2-11
	2-14 Packaging Data - - - - -	2-12
	2-15 Equipment Inspection - - - - -	2-13
	2-16 Uncrating Methods - - - - -	2-13
III	INSTALLATION PROCEDURE	
	2-17 Scope - - - - -	2-19
	2-18 General Instructions - - - - -	2-19
	2-19 Procedure - - - - -	2-20
CHAPTER 3. CIRCUIT DIAGRAMS		
	3-1 Introduction - - - - -	3-1

LIST OF ILLUSTRATIONS

Figure		Page
CHAPTER 1. GENERAL INFORMATION		
1-1	TMC Model GPT-10KR General Purpose Transmitter (Synthesized) - - - - -	1-0
1-2	General Component Identification (2 sheets) - -	1-2
CHAPTER 2. INSTALLATION		
2-1	Typical Input Power Cabling Requirements, Installation Diagram - - - - -	2-3
2-2	Dimensional Clearance Requirements, Installation Diagram (2 sheets) - - - - -	2-7/2-8
2-3	Typical Equipment Packaging (4 sheets) - - - - -	2-14

LIST OF ILLUSTRATIONS (cont)

Figure		Page
CHAPTER 2. INSTALLATION (cont)		
2-4	Base Assembly for the First and Second Frames, Installation Diagram - - - - -	2-22
2-5	Ground Strap, Installation Diagram - - - - -	2-22
2-6	First and Second Frames Installation Diagram - -	2-24
2-7	Lower Compartment of the Second Frame, Rear View - - - - -	2-27
2-8	Upper Compartment of Second Frame, Rear View - -	2-28
2-9	Upper Compartment of Second Frame, Side View - -	2-30
2-10	Antenna Coupler, Rear View - - - - -	2-31
2-11	Balanced Output Bowl Assemblies, Installation Diagram - - - - -	2-33
2-12	Transformer T800, Installation Diagram - - - -	2-34
2-13	First Frame, Front and Rear View - - - - -	2-36
2-14	High Voltage Rectifier Drawer 600, Top View - - -	2-37
2-15	RFC Amplifier Drawer, Top View - - - - -	2-38
2-16	Exterior Covers and Trim, Installation Diagram - -	2-41/2-42
2-17	Door Latch Plates and Brackets, Installation Diagram - - - - -	2-40
CHAPTER 3. CIRCUIT DIAGRAMS		
3-1	Line Filterboard A-3479, Cable Connection Diagram - - - - -	3-2
3-2	Transformer T800, Cable Connection Diagram - - -	3-3
3-3	Filterboard, Cable Connection Diagram - - - - -	3-4
3-4	First Frame Drawer, Cable Connection Diagram - -	3-5/3-6
3-5	Rf Amplifier Drawer, Cable Connection Diagram - -	3-7

LIST OF TABLES

Table		Page
CHAPTER 1. GENERAL INFORMATION		
1-1	Leading Particulars - - - - -	1-5/1-6
1-2	Capabilities and Limitations - - - - -	1-7
1-3	Equipment Supplied - - - - -	1-10
1-4	Equipment Required But Not Supplied - - - - -	1-24
1-5	Associated Manuals - - - - -	1-25
CHAPTER 2. INSTALLATION		
2-1	Crated Weights and Dimensions - - - - -	2-12

INTRODUCTION

This manual presents information for installing a TMC Model GPT-10KR General Purpose Transmitter (synthesized), commonly called the 10K transmitter. The manual is subdivided into three chapters: General Information, Installation, and Circuit Diagrams. If further information on the 10K transmitter is required, refer to the operation and maintenance manuals.

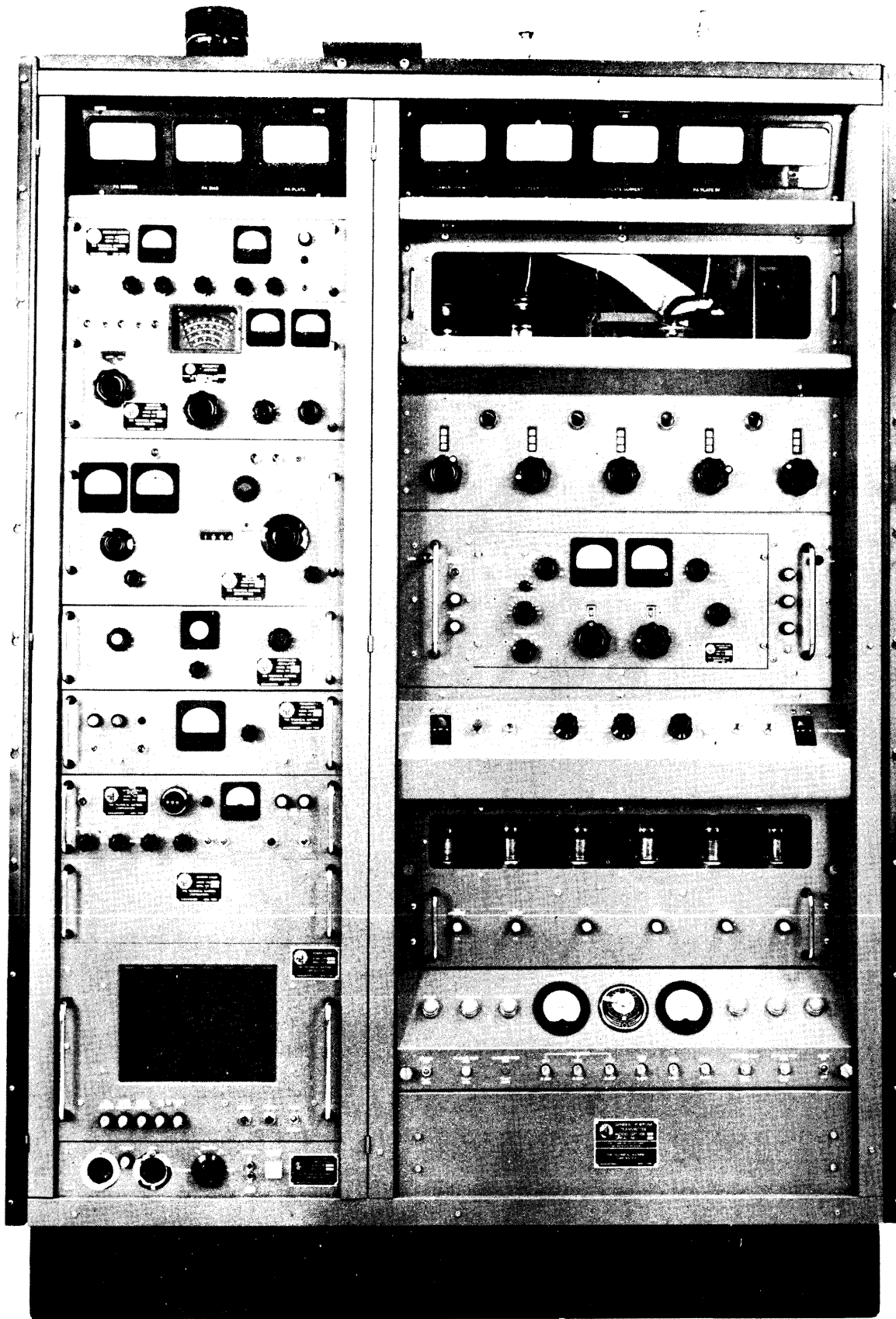

Figure 1-1. TMC Model GPT-10KR General Purpose Transmitter (Synthesized).

CHAPTER 1
GENERAL INFORMATION

1-1. SCOPE.

This chapter presents general information concerning purpose and description of the 10K transmitter. Included in this information are leading particulars, capabilities and limitations, equipment supplied, equipment required but not supplied, and associated manuals.

1-2. PURPOSE AND DESCRIPTION.

The 10K transmitter, figure 1-1, is a general purpose synthesized transmitter having several modes of operation (SSB, ISB, AM, AM equivalent, CW, FSK and FAX) in a frequency range of 2 to 28 megacycles. The output of the transmitter is 10 kilowatts (kw) peak envelope power (PEP).

The 10K transmitter is physically housed in two mechanical frame assemblies. Each can be conveniently identified, figure 1-2 (from left to right), as the first and second frames. The first frame is the exciter. The second frame is the 10kw power amplifier. However, for purposes of simplification, each frame assembly will be herein referred to as the first frame or second frame, as applicable.

FIRST
 FRAME AX-239
 SYMBOL 3000
 SUBASSEMBLY AX-181

SECOND
 FRAME AX-186
 SYMBOL 1000
 SUBASSEMBLY AX-182

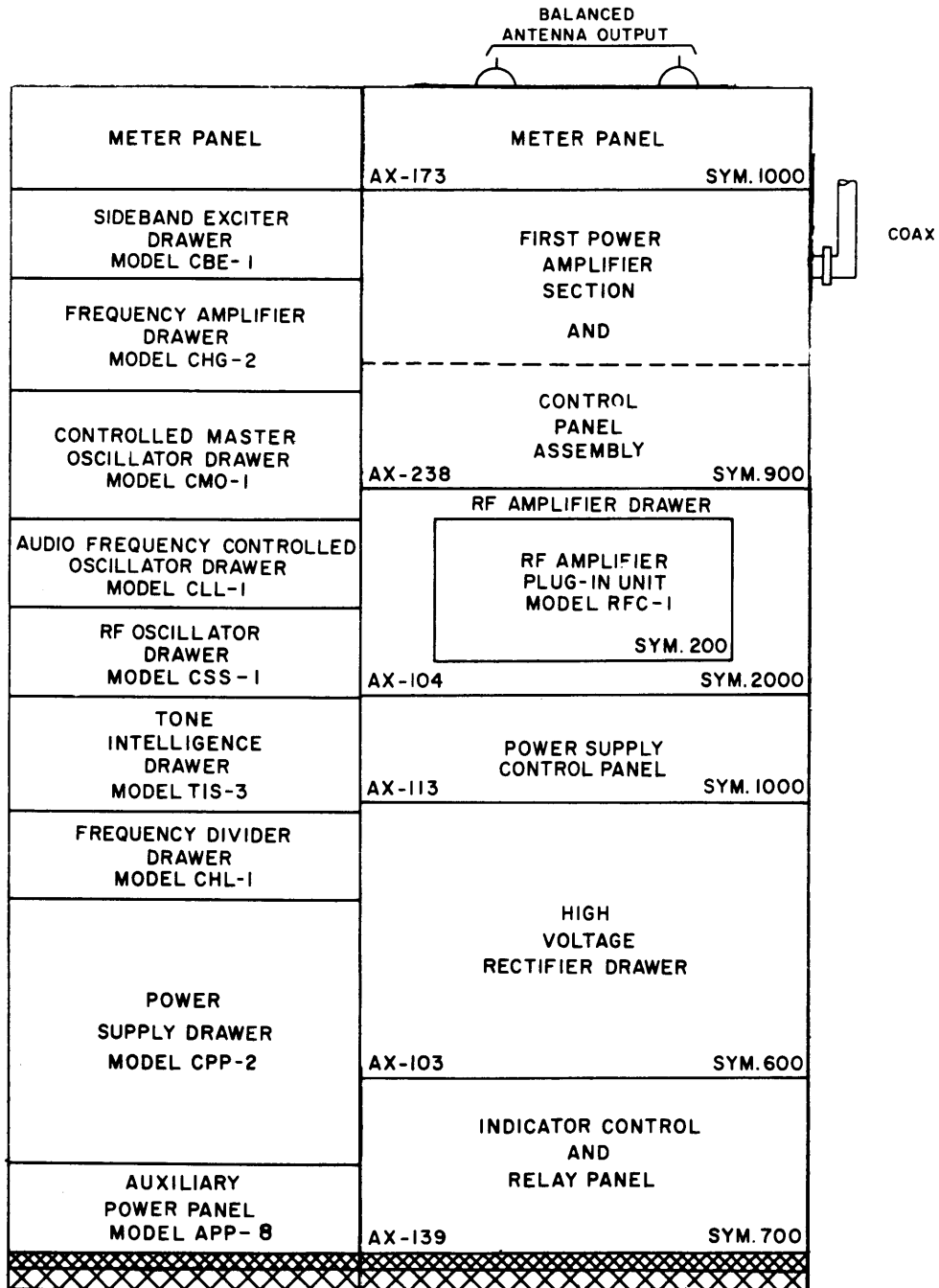

Figure 1-2. General Component Identification
 (Sheet 1 of 2)

SECOND
FRAME AX-186
SYMBOL 1000
SUBASSEMBLY AX-182

FIRST
FRAME AX-239
SYMBOL 3000
SUBASSEMBLY AX-181

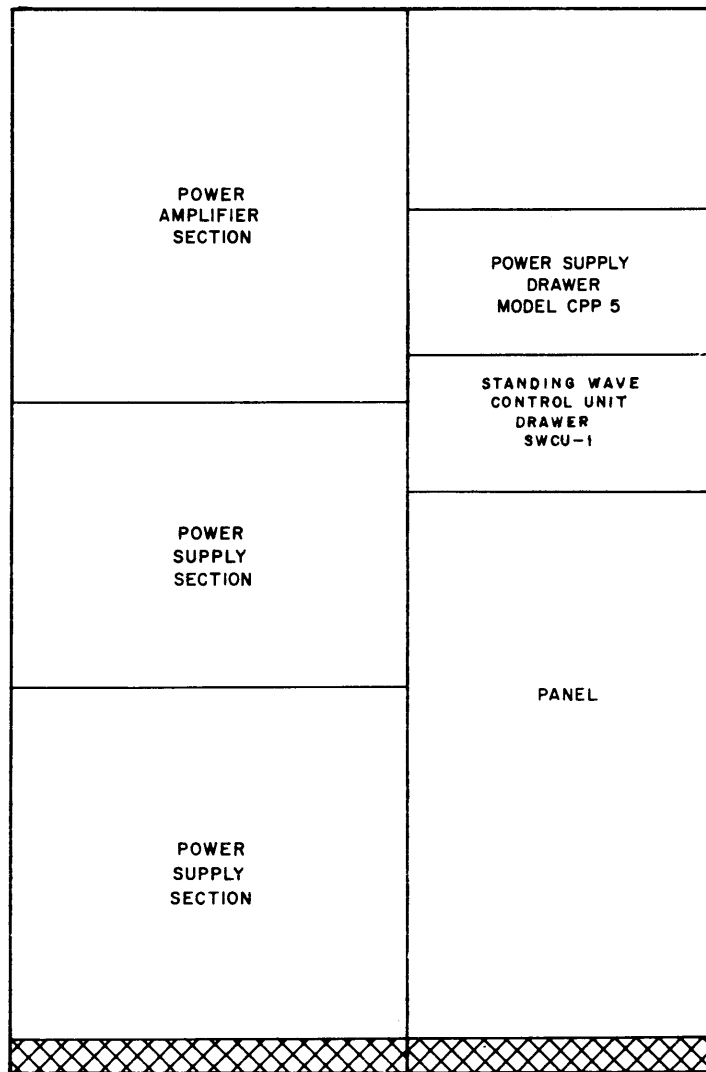

Figure 1-2. General Component Identification
(Sheet 2 of 2)

A more detailed subdivision of the transmitter is made by assigning formal nomenclature and part numbers to assemblies, subassemblies, components, and piece-parts. In addition to formal nomenclature and part numbers, common names are used and simplified reference symbol numbers are assigned. For example, the second frame and assemblies contained, figure 1-2, are assigned simplified symbol numbers in the 600 to 2000 numerical series; so that high voltage rectifier tube V600 is installed in the high voltage rectifier drawer 600 which is then installed in the second frame 3000.

1-3. LEADING PARTICULARS.

Table 1-1 lists logistic type leading particulars of the 10k transmitter. Characteristics listed cover primary power, overall equipment dimensions, gross weight, and air cooling.

Table 1-1. Leading Particulars

NOMENCLATURE		POWER REQUIREMENTS					DIMENSIONS IN INCHES			WEIGHT	FORCED AIR COOLING REQUIREMENTS	
FORMAL	COMMON	VOLTS	AMP	W	PH	FREQ IN CPS	HGT	W	D	IN LB	CFM	BP IN INCHES OF WATER
General Purpose Transmitter Model GPT-10K	10k transmitter	230	60 /PH	20k	3	50-60	86 (OA)	55- 3/4 (OA)	43-1/2 (OA)			
Cabinet, Electrical Equipment	First frame	115			1	50-60	72	21	38-5/8	385		
Sideband Exciter Drawer Model CBE-1	Sideband exciter drawer	115			1	50-60	5-1/4	19	12-7/8	17		
Frequency Amplifier Drawer Model CHG-2A	Frequency amplifier drawer	a					10-1/2	19	19-1/4	40		
Controlled Master Oscil- lator Drawer Model CMO-1	Controlled master oscil- lator drawer	b					10-1/2	19	18	45		
Audio Frequency Controlled Oscillator Drawer Model CLL-1	Audio frequency controlled oscillator drawer	c					5-1/4	19	19	25		
RF Oscillator Drawer Model CSS-1B	Rf oscillator drawer	115		30- 50	1	50-60	5-1/4	19	14-3/4	30		
Tone Intelligence Drawer Model TIS-3	Tone intelligence drawer	115	1	100	1	50-60	5-1/4	19	17-1/8	26		
Frequency Divider Drawer Model CHL-1	Frequency divider drawer	d					5-1/4	19	15	20		
Power Supply Drawer Model CPP-2	Power supply drawer	115		1k	1	50-60	12-1/4	19	16	67		
Auxiliary Power Panel Model APP-8	Auxiliary power panel						3-1/2	19	4	10		
Power Supply Drawer Model CPP-5	Power supply drawer	115			1		5-1/4	19	16-1/2	50		
Standing Wave Control Unit Model SWCU-1	Standing wave control unit drawer	115			1	50-60	3-1/2	19		15		
Cabinet, Electrical	Second frame	230			3	50-60	72	32	33-5/8	835 ^e		
Rf Amplifier drawer, with:	Rf amplifier drawer	230			3	50-60	11-3/4	28-3/4	20-1/2	100		
Rf Amplifier Plug-In Unit Model RFC-1	Rfc drawer	f										
High Voltage Rectifier Drawer	HVR drawer	3400			3	50-60	10-3/4	28-3/4	16-3/4	80		

a. +150 vdc (regulated). +200 vdc (unregulated). 6.3 vac.

b. +160 and -6 vdc, and 6.3 vac (regulated). +380 vdc and 115 vac (unregulated).

c. +160, -75, and -6 vdc, and 6.3 vac (regulated). -400 and +380vdc, and 115 vac (unregulated).

d. +160 and -6 vdc, and 6.3 vac (unregulated)

e. Weight as shipped.

f. +400, +200, -150, and -100 dc. 230 vac, 3Ø,
50-60 cps 12 and 6.3 vac.

1-4. CAPABILITIES AND LIMITATIONS.

Table 1-2 lists operational type capabilities and limitations of the 10K transmitter. Data presented covers functional and environmental characteristics.

Table 1-2. Capabilities and Limitations

CAPABILITIES	LIMITATIONS
<p>Functional Characteristics:</p> <p>Frequency range</p> <p>Modes of operation</p> <p>Output power:</p> <p>Normal</p> <p>Emergency</p> <p>Output Impedance:</p> <p>Unbalanced</p> <p>Balanced</p> <p>Tuning</p> <p>Stability and accuracy</p> <p>Unwanted sideband rejection</p>	<p>2 to 28 megacycles.</p> <p>SSB, ISB, AM, AM equivalent, CW, FSK, and FAX.</p> <p>10,000 watts peak envelope power (PEP).</p> <p>1,000 watts.</p> <p>Pi-L network matches load with voltage standing wave ratio (VSWR) of 2:1 maximum.</p> <p>50 or 70 ohms.</p> <p>600 ohms.</p> <p>Synthesized frequency control with 100 cycles per second (cps) incremental front panel tuning through the entire frequency range.</p> <p>1 part in 10^8 per day for ambient temperature change of 15°C (59°F) within the range of 0° to 50°C (32° to 122°F).</p> <p>500 cps single tone 60db down from full PEP output.</p>

Table 1-2. Capabilities and Limitations (cont)

CAPABILITIES	LIMITATIONS
Spurious signals	At least 60 db below full PEP output.
Carrier insertion	-55 db to full PEP output.
Audio response	CBE-1 crystal lattice filters flat within ± 1.5 db 250 to 7500 cps.
Audio inputs	600 ohms balanced -20 to +10 dbm continuously adjustable to full PEP output. An unbalanced input can also be applied.
Heat dissipation	40 kw (maximum)
Keying:	
FSK	75 bauds (100 wpm) maximum 50 _v , 100 _v , 20 ma, 60 ma, all neutral, floating, or either side grounded. 12 to 1,000 cps shift.
CW	140 bauds maximum. Keying voltages same as FSK plus dry contact keying. -5 to +5vdc or 0 to +20vdc for linear shift of 12,000 cycles.
Environmental characteristics:	
Ambient operating temperature	Between 0° and 50°C (32° and 122°F).
Humidity	Maximum 90%.
Volume of air:	
Intake	2600 CFM (est)
Exhaust	2340 CFM (est)
Intake and exhaust openings:	
Intake	One 13-1/2" x 28"
Exhaust	One 10-1/2" x 21"

Table 1-2. Capabilities and Limitations (cont)

CAPABILITIES	LIMITATIONS
Heat loss unducted: Standby Full power condition Temperature Rise: Standby Full power condition	5.0kw (approximately) 8.0kw (approximately) 15°C (59°F) 20° to 25°C (68° to 77°F)

1-5. EQUIPMENT SUPPLIED.

Table 1-3 lists all major equipment supplied by crate number, contents, quantity, TMC part numbers, and reference symbol designations. Also a brief function of each item is provided. Subassemblies of assemblies presented are not callout; identification of subassemblies can be obtained by referring to the applicable operations and maintenance manuals. Spare parts are not included in the table.

Table 1-3. Equipment Supplied

CRATE NO.	CONTENTS	QTY	DESIGNATIONS		FUNCTION
			TMC P/N	SYM	
1	Loose Items:				
	1. Bag -- Mounting Kit, Grounding Strap:				Ground strap mounting hardware (hdwr)
	Screw, Machine, Hex-head	1	SCHH6211BN24		
	Washer, Lock	4	LWS62MRN		
	Washer, Flat	9	FW62HBN		
	Nut, Hexhead	3	NTH6211BN32		
	2. Bag -- Mounting Kit, Frame to 10k Base				First and second frame to base mounting hdwr
	Screw, Machine, Hex-head	10	SCHH3716SS24		
	Washer, Lock	10	LWS37MRN		
	Washer, Flat	10	FW37HBN		Line filterboard mounting hdwr
3. Bag -- Line Filterboard, Mounting Hardware Kit:					
Screw, Machine, Binderhead	4	SCBP1032BN6			
Screw, Machine, Binderhead	4	SCBP1032BN12			

Table 1-3. Equipment Supplied (cont)

CRATE NO.	CONTENTS	QTY	DESIGNATIONS		FUNCTION
			TMC P/N	SYM	
1 (cont)	3. (cont)				
	Screw, Machine, Binderhead	1	SCBP1032BN9		
	Screw, Machine, Binderhead	1	SCBP1032BN10		
	Washer, Flat	10	FW10MRN		
	Washer, External	10	LWE10MRN		
	Nut, Hexhead	4	NTH1032BN12		
	4. Bag -- Assembly Kit, Auxiliary and Main Frame:				Frame to frame mounting hdwr
	Screw, Machine, Hex-head	10	SCHH3118SN16		
	Washer, Lock	10	LWS1MRN		
	Washer, Flat	10	FW31HBN		
	5. Bag -- Mounting, Main Power Transformer:				Transformer T800 to frame mounting hdwr
	Screw, Machine, Hex-head	4	SCHH5013SS48		
	Washer, Lock	4	LWS50HBN		
	Washer, Flat	4	FW40MRN		

Table 1-3. Equipment Supplied (cont)

CRATE NO.	CONTENTS	QTY	DESIGNATIONS		FUNCTION
			TMC P/N	SYM	
1 (cont)	6. Bag -- Equipment Mounting Hardware Kit:				Drawer to frame mounting hdwr
	Screw, Machine, Binderhead	44	SCBP1032BN8		
	Washer, Fiber	44	WA-101-5		
	7. Bag -- Mounting Kit, Door Latch Brackets:				Door latch plates and brackets to frame mounting hdwr
	Screw, Machine, Binderhead	8	SCBP1032BN10		
	Screw, Flat	8	SCFP1032BN8		
	Washer, Lock External	8	LWE10MRN		
	Washer, Lock	8	LWS10MRN		
	Washer, Flat	8	FW10HBN		
	Washer, Flat	8	FW25HBN		
	Nut, Hexhead	8	NTH1032BN12		Trim strips to frame mounting hdwr
	8. Bag -- Mounting, Trim Strip:				
Screw, Machine, Binderhead	33	SCBP0832BN6			
Nut, Speed	12	NT-108-5			

Table 1-3. Equipment Supplied (cont)

CRATE NO.	CONTENTS	QTY	DESIGNATIONS		FUNCTION
			TMC P/N	SYM	
1 (cont)	9. Bag -- Mounting Kit, Exterior Covers to Frame:				Side panels to frame mounting hdwr
	Screw, Machine, Hex-head	20	SCHH3118SS24		
	Washer, Lock	20	LWS31MRN		
	Washer, Flat	20	FW31HBN		Cover top to frame mounting hdwr
	10. Bag -- Assembly Kit, Transmitter Top:				
	Screw, Machine, Hex-head		SCHH2520SS24		
	Washer, Lock		LWS25MRN		Antenna coupler mounting hdwr
	Washer, Flat		FW25HBN		
	11. Bag -- Antenna Coupler, Mounting Hardware Kit:				
	Screw, Machine, Hex-head	2	SCHH2520BN7		
	Screw, Machine, Binderhead	2	SCBP1032BN9		
Screw, Flathead	2	SCFP1032BN9			

Table 1-3. Equipment Supplied (cont)

CRATE NO.	CONTENTS	QTY	DESIGNATIONS		FUNCTION	
			TMC P/N	SYM		
1 (cont)	11. (cont)					
	Washer, Flat	2	FW10MRN			
	Washer, Lock	2	LWS25MRN			
	Washer, External	2	LWE10MRN			
	12. Manuals, Technical	1 set				
	13. Data, Test	1 set				
	14. Eitel McCulloch Warranty	1			Warranty for tube TMC P/N 4CX5000A	
	15. Penta Laboratory Warranty	1			Warranty for Tube TMC P/N TV-100	
	16. Sola Voltage Regulator	1			Warranty for voltage regulator	
	17. Straps, Grounding				Ground first and second frames	
			2	MS-1753-2-18		
			2	MS-1753-2-30		

Table 1-3. Equipment Supplied (cont)

CRATE NO.	CONTENTS	QTY	DESIGNATIONS		FUNCTION			
			TMC P/N	SYM				
1 (cont)	18. Resistors, Fixed	8	RW-118F-183	R802 thru R809	High wattage power supply bleeder resistors, rear second frame			
			RW11-118F-502	R816, R819, R820				
			RW-119G-181	R812, R813,				
			RW-122-3-604	R814, R815				
			RW-122-1-405	R810, R811				
			19. Capacitor, Variable with PO-185-1 and MS-1696	1		AM-103	C916	Output balance, second frame
						AM-113	C927	Tuning second frame
						AM-114	C928	Load second frame

Table 1-3. Equipment Supplied (cont)

CRATE NO.	CONTENTS	QTY	DESIGNATIONS		FUNCTION	
			TMC P/N	SYM		
1 (cont)	20. Tube, Electron	1	TV-100	V203	Output tube, second frame	
		6	872-A	V600 thru V605	H.V. rectifier, second frame	
		1	4CX5000A	V900	PA tube, second frame	
	21. Lamp Socket Assembly, High Voltage and	1	AX-124		H.V. indicator, top first frame	
		1	BI-106-1	I300	Lamp for indicator	
	22. Plugs, Electrical	1	PL-134		Female plug for customer use in connecting to convenience ac outlet jack, bottom front panel, first frame	
		1	PL-149		Universal connector plug for customer use, in connecting to jack J904, top second frame	
			1	PL-157		Connector plugs for customer use in connecting to MONITOR OUTPUT jack, bottom front panel, first frame

Table 1-3. Equipment Supplied (cont)

CRATE NO.	CONTENTS	QTY	DESIGNATIONS		FUNCTION
			TMC P/N	SYM	
1 (cont)	22. (cont)	2	PL-218		Male plug for customer use in making an extension cord in conjunction with plug PL-134
	23. Balanced Output Bowl Rods with hdwr	2	A-1403		
	24. Door Latch Plates:				Securing doors to first through fourth frames
	Bottom Front Rear	6	MS-2122		
	Top Front and Rear	6	MS-1660		Same as item 31
	25. Door Latch Brackets				
	Top, Front, and Rear	6	MS-1661		Dress side panels and covers
	26. Plugs, Button:				
	1/2 inch	8	HB-101-3		
	7/8 inch	32	HB-101-6		

Table 1-3. Equipment Supplied (cont)

CRATE NO.	CONTENTS	QTY	DESIGNATIONS		FUNCTION	
			TMC P/N	SYM		
1 (cont)	27. Cable, Emergency Output	1	CA-582-1		Emergency output cable	
	28. Line Filterboard	1	A-3479		Filter ac input line voltage	
	29. Line Filterboard				Brackets for mounting cover	
	Bracket, Cover Support	2	MS-3689			
	30. Cover, Line Filterboard	1	LD-1392		Safety Cover	
	31. Antenna Coupler	1	A-3426	DC900	Unbalanced output antenna coupler	
	32. Cover, Plates: with hdwr with hdwr		1	MS-2442		Dust cover plates for balanced and unbalanced output holes in transmitter exterior trim. Supplied as loose item only when transmitter is shipped balanced or unbalanced.
			1	MS-2338		
			1	MS-1665		
	33. Insulator Bowl Assembly	2	AX-159		Porcelain insulator balanced output bowls supplied as a loose item only when transmitter is shipped unbalanced.	

Table 1-3. Equipment Supplied (cont)

CRATE NO.	CONTENTS	QTY	DESIGNATIONS		FUNCTION
			TMC P/N	SYM	
1 (cont)	34" Strap, Grounding	1	MS-202-19-13.12		Metal strap used for wiring output terminal board. Supplied as a loose item when transmitter is shipped unbalanced.
2	Mounting Base Assembly, with shield and access doors	1			Metal structure that can be bolted to floor and, first and second frames are bolted on
3	First Frame Assembly, with: Meter Panel Assembly	1 1	AX-239	3000	Metal cabinet that houses electrical equipment
4	Power Distribution panel	1	Model APP-8 Ser. No. 6275		Equipment status indicators, top first frame
	Standing Wave Control Unit Drawer	1	Model SW-CU-1		
	Second Frame Assembly, with: Power Amplifier	1 1	AX-186 AX-238	1000	Metal cabinet that houses electrical equipment power amplifier
	Main Power Panel Relay Panel	1 1	AX-139	700	Indicator control and relay panel

Table 1-3. Equipment Supplied (cont)

CRATE NO.	CONTENTS	QTY	DESIGNATIONS		FUNCTION
			TMC P/N	SYM	
5	Power Transformer	1	TF-203	T800	Main power transformer, second frame
6	Drawer Assemblies: 1. Power Supply, Drawer Assembly 2. Frequency Divider, Drawer Assembly 3. R-F Oscillator, Drawer Assembly	1	Model CPP-5 Model CHL-1 Model CSS-1		Power supply drawer, rear first frame Frequency divider drawer, first frame R-F oscillator drawer, first frame
7	Drawer Assemblies: 1. A-F Controlled Oscillator, Drawer Assembly 2. Tone Intelligence, Drawer Assembly 3. Sideband Exciter, Drawer Assembly	1	Model CLL-1 Model TIS-3 Model CBE-1		A-F oscillator drawer, first frame Tone intelligence drawer, first frame Sideband exciter drawer, first frame
8	Drawer Assemblies: 1. Controlled Master Oscillator, Drawer Assembly	1	Model CMO-1		Controlled master oscillator drawer, first frame

Table 1-3. Equipment Supplied (cont)

CRATE NO.	CONTENTS	QTY	DESIGNATIONS		FUNCTION
			TMC P/N	SYM	
8 (cont)	2. Frequency Amplifier, Drawer Assembly	1	Model CHG-2		Frequency amplifier drawer, first frame
9	Power Supply, Drawer Assembly	1	Model CPP-2		Power supply drawer, first frame
10	High-Voltage Rectifier, Drawer Assembly	1	AX-103	600	H.V.R., second frame
11	RF Amplifier Drawer Assembly with plug-in RF Amplifier unit Model RFC-1	1	AX-104	2000	RF amplifier and control panel, second frame
12	Exterior Covers and Trim strips:	1			Exterior doors, covers, and trim strips for the first and second frames
	1. Second Frame Trim, Front Left Side	1	MS-1634		
	2. First and Second Frame Trim, Front top	1	MS-1635		
	3. First and Second Frame Trim, Front Bottom	1	MS-1636		
	4. First Frame Trim, Front Hinged Right Side	1	MS-1637		

Table 1-3. Equipment Supplied (cont)

CRATE NO.	CONTENTS	QTY	DESIGNATIONS		FUNCTION
			TMC P/N	SYM	
12 (cont)	5. First Frame Door, Rear	1	MS-1648		
	6. First and Second Frame Trim, Rear Center	1	MS-1669		
	7. First Frame Trim, Rear Right Side	1	MS-1670		
	8. Second Frame Trim, Rear Left Side	1	MS-1671		
	9. First and Second Frame Trim, Rear Top and Bottom	2	MS-1672		
	10. First and Second Frame Cover, Top	1	MS-1699		
	11. First Frame Trim, Front Hinged Left Side	1	MS-1920		
	12. Second Frame Trim, Front	1	MS-1633		
	13. Second Frame Door, Rear	1	MS-1647		
	14. Second Frame Panel, Right Side	1	MS-2116		

Table 1-3. Equipment Supplied (cont)

CRATE NO.	CONTENTS	QTY	DESIGNATIONS		FUNCTION
			TMC P/N	SYM	
12 (cont)	15. First Frame Panel, Left Side	1	MS-2117		
	16. Second Frame Door, Front	1	MS-2118		
	17. First Frame Door, Front	1	MS-2119		

1-6. EQUIPMENT REQUIRED BUT NOT SUPPLIED.

Table 1-4 list equipment required to install the 10K transmitter. Although items are required, they are not supplied.

Table 1-4. Equipment Required But Not Supplied

EQUIPMENT	PURPOSE
1. Box Wrenches, assorted sizes	Fastening mounting hardware
2. Open End Wrenches, assorted sizes	Same as item 1
3. Spin Tights, sizes: 3/16, 1/4, 5/16, 3/8, 7/16, 1/2, 9/16	Same as item 1
4. Socket Wrench Set, socket sizes to 1-1/8	Same as item 1
5. Screw Drivers, Flat Head, assorted sizes	Same as item 1
6. Screw Drivers, Phillips-head, assorted	Same as item 1
7. Crowbar	Open packing crates
8. Fork-Lift or equivalent	Moving heavy objects (e.g. packing crates and voltage transformers)
9. Low-Speed Electric Drill and carborundum bit or equivalent	Drilling equipment anchoring holes
10. Case cutter	Open cardboard packing cases
11. Nail puller	Open packing crates
12. Pair of snips	Cutting strap bands

1-7. ASSOCIATED MANUALS.

Table 1-5 presents a list of associated equipment manuals. This list provides a convenient reference for readily obtaining information on the 10K transmitter.

Table 1-5. Associated Manuals

EQUIPMENT	MANUAL
First Frame	
Sideband exciter drawer	
Frequency amplifier drawer	
Controlled master oscillator drawer	Maintenance Instructions for Transmitting Set, Radio, Model GPT-10K .
Audio frequency controlled oscillator drawer	
Rf oscillator drawer	
Tone intelligence drawer	
Frequency divider drawer	Transmitting Radio Set, Model GPT-10K, Vol. IS.
Power Supply drawer CPP-2	
Auxiliary power panel	
Power Supply drawer CPP-5	
Standing wave control unit drawer	
Second Frame	
Rf amplifier drawer	
Rfc drawer	
HVR drawer 600	

CHAPTER 2

INSTALLATION

2-1. INTRODUCTION.

The intent of this chapter is to present three sections of installation information. Section I discusses pre-installation considerations. Section II presents logistic data. Section III is the installation procedure.

SECTION I

PRE-INSTALLATION

2-2. SCOPE.

This section presents pre-installation considerations that warrant planning before undertaking transmitter assemblage. Although information presented is for a 10K transmitter land installation, it may be applicable to a mobile-van or shipboard installation.

2-3. ENVIRONMENT.

The 10K transmitter operates under a broad range of environmental conditions (refer to table 1-2) . These conditions must be taken into consideration when selecting the equipment location.

2-4. LOCATION OF PERIPHERAL EQUIPMENT.

There is no distance limitation governing the location of peripheral equipment (i.e. facsimile and teletype machines microphones, keys, test equipment, etc.) other than providing practical and compatible interequipment operation (refer table 1-2).

Consideration should be given to the routing and length of input signal cables before assembling the transmitter. Signal input cable entry is made through the base assemblies of the equipment during installation. All signal inputs are spade lug connections terminating inside the rear of the first frame. This point can be used as a reference in determining exact input signal cable lengths.

2-5. AC INPUT POWER REQUIREMENTS.

Three methods of laying out input power cables can be used. Figure 2-1 illustrates the sub-floor-level cable raceway method, which requires provisioning for troughs during construction of the building. If these provisions have not been made, removable access plates, located on the base assemblies, permit cable entry in the floor-level and ceiling routing methods.

It should be noted that input power under full power output conditions is based on the maximum allowable plate dissipation of the final amplifier rather than on various modes of operation. Primary input power under standby and full power conditions are 6.5 kw and 15.0 kw, respectively. In fulfilling practical and adequate ac input power requirements, consider the transmitter draws 20 kw. This requirement can be used in providing the appropriate size peripheral ac input power line, switch or breaker boxes and etc for the transmitter. Under maximum current conditions the transmitter draws 60 amperes per phase.

— REAR VIEW —

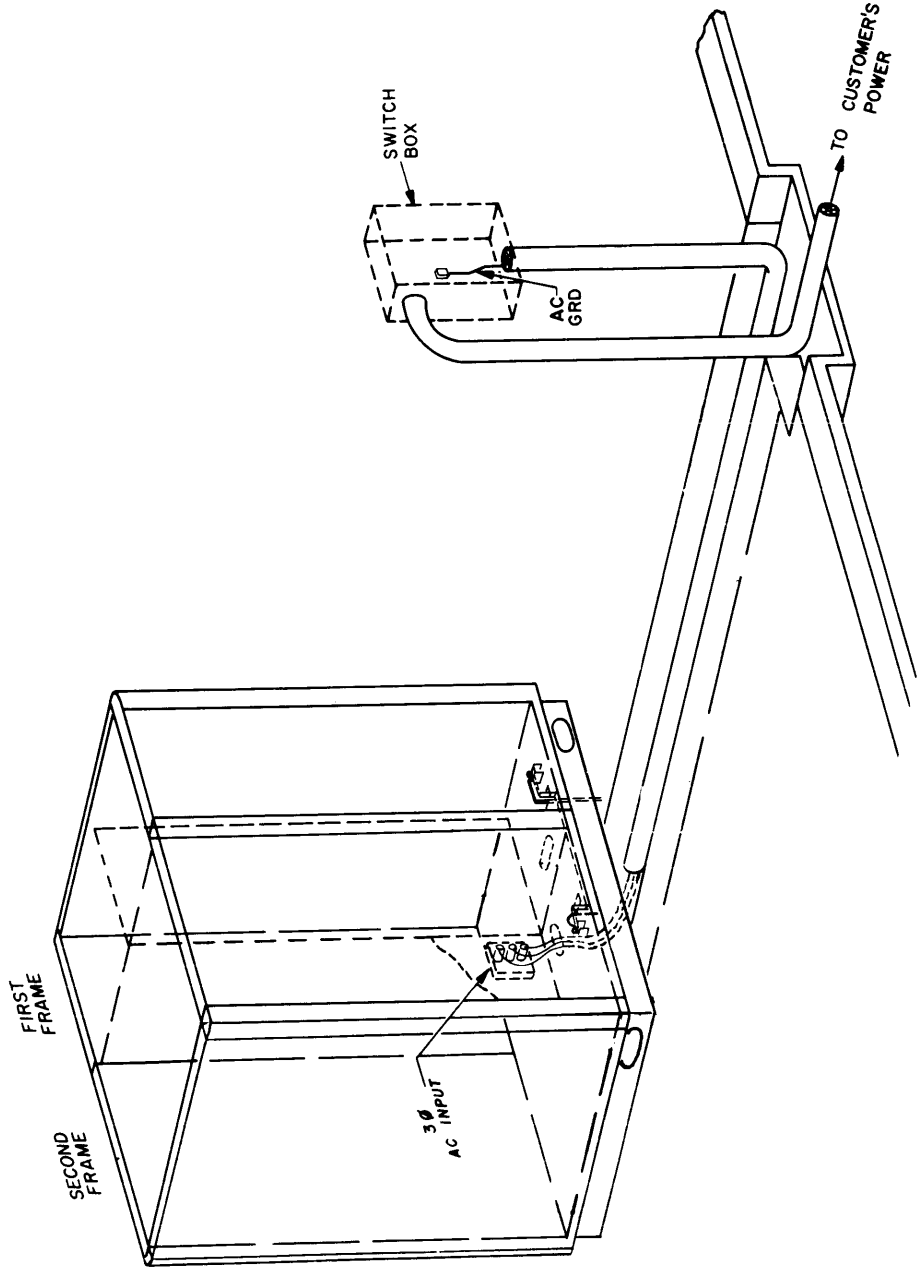

Figure 2-1. Typical Input Power Cabling Requirements, Installation Diagram.

2-6. STATION GROUND.

The 10K transmitter must be grounded to station ground. Accordingly, a 5/8-11 nut has been centered and welded to the base assembly of the transmitter. The exact location of the nut is 11-1/4 inches in from the rear corner on the inside of the base assembly, under the first frame. If the station ground has not been established, locate an appropriate station ground cable in this vicinity before starting the installation procedure. Complementary hardware for the welded nut is provided to connect station ground to the transmitter during installation.

2-7. EQUIPMENT ANCHORING.

Anchoring the transmitter to the floor in a land installation should not be necessary to maintain stability, since gross equipment weight is approximately 2,500 lbs. However, in a shipboard or mobile-van installation, anchoring the transmitter may be employed. Using the base assemblies drilled holes as a template during assembly, the desired anchor techniques (including shock mounting) may be used.

2-8. ANTENNA TRANSMISSION LINE.

The output impedance or load for the 10K transmitter is 50 or 70 ohms (unbalanced output) or 600 ohms (balanced output). When working into either load, it is not necessary to use a rigid transmission line. For unbalanced operation, flexible 3-1/8 inch coaxial line is required. Or, for balanced operation, a pair of insulated #6 copper wires is required. The length of the transmission line(s) is governed by physical routing distance between the transmitter and antenna.

A 3-1/8 inch standard EIA (Electronics Industry Association) flange connector is used as the unbalanced output jack of the transmitter. Any compatible connector plug may be used on the end of the transmission line.

2-9. PERIPHERAL AIR CONDITIONING.

The transmitter cabinets are semi-pressurized and forced-air cooled, refer to table 1-2, by self-contained blowers. Approximately 90 percent of the heat generated by the transmitter is dissipated through exhaust air-ducts. The remaining 10 percent (maximum) of the heat is radiated by the surface area of the transmitter. This 10 percent will load the room air conditioning system. The load imposed upon the room air conditioner and subsequently room-temperature should be taken into consideration.

2-10. DIMENSIONAL CLEARANCES.

Figure 2-2 illustrates minimum dimensional clearances required for typical 10K transmitter installation. Additional clearance considerations are discussed in following paragraphs.

Physically, the largest single part of the transmitter is an uncrated frame assembly, measuring three feet wide, three and a half feet deep, and six and a half feet high (approximately). These dimensions necessitate entrance door(s) sizes, leading to the intended installation point, which will allow adequate frame passage.

Figure 2-2 also presents air intake and exhaust port dimensions for transmitter top covers and side panels. After planning final transmitter location, these dimensions can be used as a reference point in and for fabricating the desired air duct system. Location and sizes of exterior wall cut-outs for the air duct system will ultimately be determined by ducting used.

The type of output transmission line (transmitter to antenna) is another clearance consideration. Construction of necessary hole sizes in the exterior walls between transmitter and antenna will be governed by type selected.

It may be practical to outline overall dimensions of the transmitter on the floor with a piece of soft chalk or a plumbline, before starting the installation procedures. After using this outline as a guide to position transmitter base assemblies, in the installation procedure, these lines could be removed.

2-11. TRANSMITTER LOCATION.

All of the proceeding data should be taken into account when locating the 10K transmitter. In addition, some practical and obvious things to consider would be: accessibility and work space, heat zones, and, habitability.

Equipment accessibility and work space should be provided for personnel to facilitate ease in installing, operating, or maintaining the transmitter. Since installation requires the greater amount of working floor area, it might be used as a criteria for locating the transmitter.

Heat zones should be avoided. These zones would be spaces above or adjacent to heating or heat producing apparatus or piping ducts.

Habitability features with respect to locating might be: neat peripheral wiring for personnel safety; and, passage clearance for personnel in the case of co-located equipments.

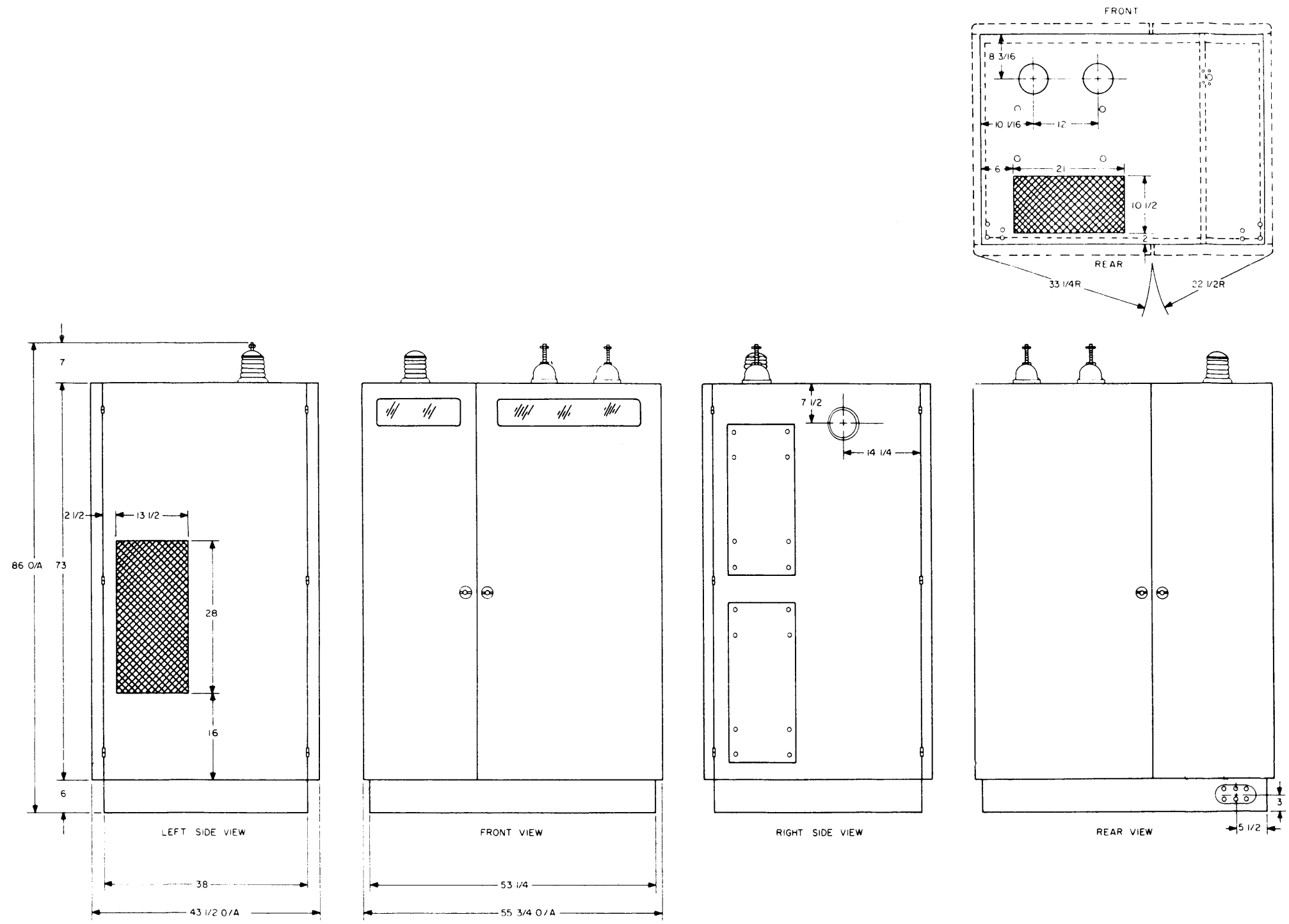

Figure 2-2. Dimensional Clearance Requirements, Installation Diagram (sheet 1 of 2).

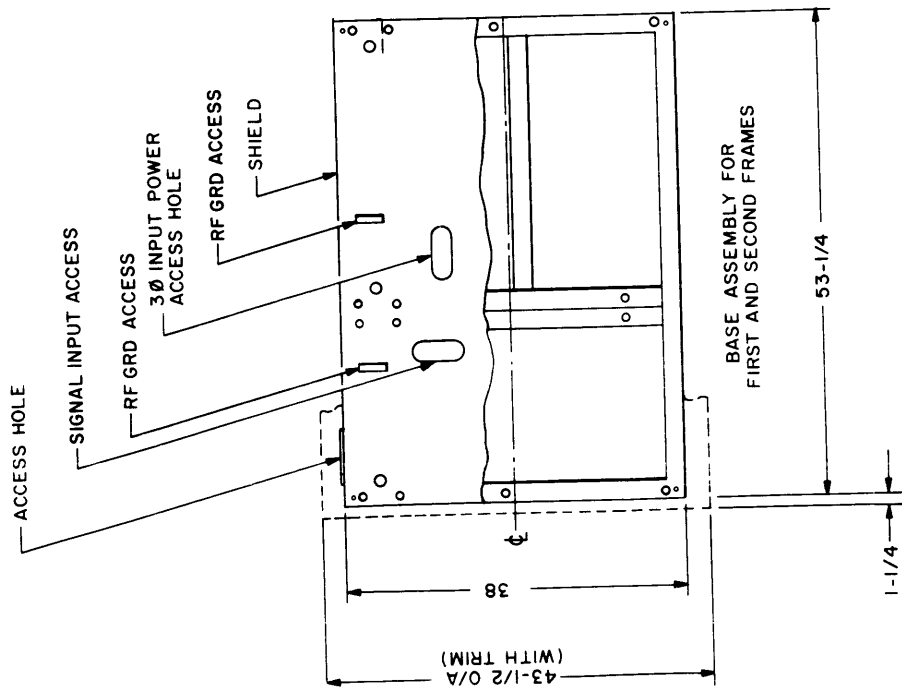

Figure 2-2. Dimensional Clearance Requirements, Installation Diagram (Sheet 2 of 2)

SECTION II

LOGISTICS

2-12. SCOPE.

This section presents logistic information. Information covered includes material handling, packaging data, equipment inspection, and uncrating methods.

2-13. MATERIAL HANDLING.

Whether the equipment is crated or uncrated, various precautions must be observed in material handling.

CAUTION

Crates must never be rolled, crushed, dropped, or struck— they contain delicate electronic apparatus that can be damaged.

General safety precautions should be adhered to when moving the equipment to prevent damage to equipment or injury to personnel. Weight alone is not an indication that equipment can be moved safely by personnel. Size is also an important consideration. A light-weight, large, and bulky item cannot easily be handled by one man. When personnel are involved in handling, a good rule-of-thumb to follow is: 50 pounds for one man; or 100 pounds for two men is considered a safe limit for carrying. When lifting an item, bend the knees, keep back straight and lift with the legs. Before handling material, refer to tables 1-1 and 2-1 for crated and uncrated weights and dimensions.

2-14. PACKAGING DATA.

The 10K transmitter is packed in 13 crates (not including running spares). Each crate is assigned a number from one to twelve and appears on the crate. Now that crate 1 has been opened and before starting the actual installation procedure, physically locate crate 1 closest to the intended point of installation; locate the other crates according to their numerical sequence such that crate 12 is placed farthest away from crate 1. Arranging crates in this manner makes unpacking and assembling the transmitter easier.

The transmitter is cleaned, preserved, packaged, and marked in accordance with MIL-P-116, PMD-40, and MIL-STD-129. Figure 2-3 illustrates typical equipment packing methods.

Table 2-1 lists the crated weights and dimensions of the 10K transmitter. Additional reference can be made to table 1-1 for uncrated weights and dimensions.

Table 2-1. Crated Weights and Dimensions

CRATE NO.	GROSS WEIGHT IN LBS.	DIMENSIONS IN INCHES		
		HGT	W	D
1	188	30-3/4	23-7/8	32
2	234	8	40-1/8	56-3/4
3	768	82-1/8	50-1/4	32-1/4
4	1298	81-3/4	42	51-1/2
5	536	28-3/4	19-3/4	24

Table 2-1. Crated Weights and Dimensions (cont)

CRATE NO.	GROSS WEIGHT IN LBS.	DIMENSIONS IN INCHES		
		HGT	W	D
6	212	30-3/4	23-7/8	32
7	202	30-3/4	23-7/8	32
8	214	30-3/4	23-7/8	32
9	143	17-1/4	21-5/8	27-1/4
10	233	22	30-3/4	40
11	240	22	30-3/4	40
12	643	44-1/4	27-1/2	77-5/8

2-15. EQUIPMENT INSPECTION.

The 10K transmitter has been assembled, calibrated, and tested at the factory before shipment. Inspect all packages for possible transit damage. While following the procedural installation instructions, carefully unpack each crate as indicated. Inspect all packing material for parts which may have been shipped as loose items.

With respect to equipment damage for which the carrier is liable, the Technical Material Corporation will assist in describing methods of repair and the furnishing of replacement parts.

2-16. UNCRATING METHODS.

The following information briefly outlines general uncrating methods. These methods must be adhered to when unpacking the transmitter to prevent equipment damage.

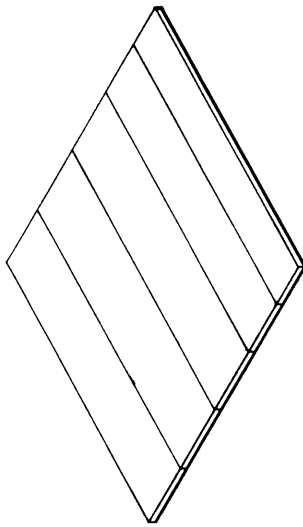

LEGEND

1. WOODEN BOX
2. STEEL STRAPPING
3. STRAPPING SEALS
4. STEEL STAPLES
5. BARRIER BAG
6. FIBERBOARD BOX
7. CELLULOSIC WADDING
8. FIBERBOARD BOX
9. PRESSURE SENSITIVE TAPE
10. BARRIER BAG
11. FIBERBOARD BOX
12. CAPACITOR
13. MOULDED CUSHIONING
14. MARKING TAPE
15. TISSUE PAPER
16. BARRIER BAG
17. FIBERBOARD BOX
18. BARRIER BAG
19. PRESSURE SENSITIVE TAPE
20. FIBERBOARD BOX
21. SHAFT AND GEAR



CARTONS 1, 2, AND 3

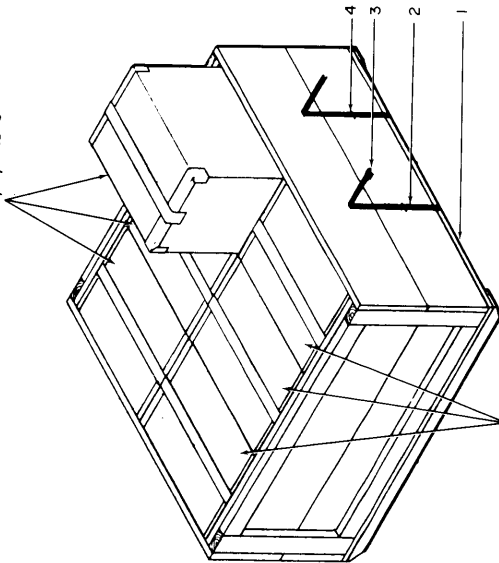

CARTONS 4, 5, AND 6

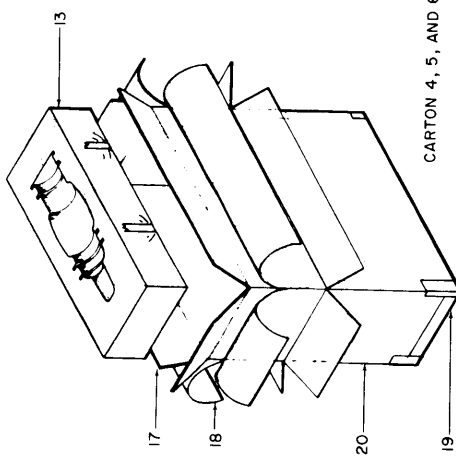
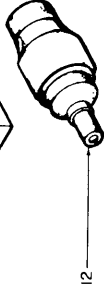
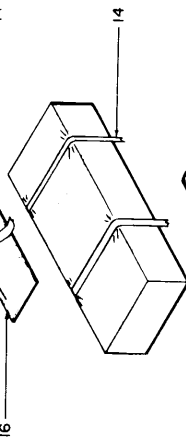

CARTON 4, 5, AND 6

DETAIL A

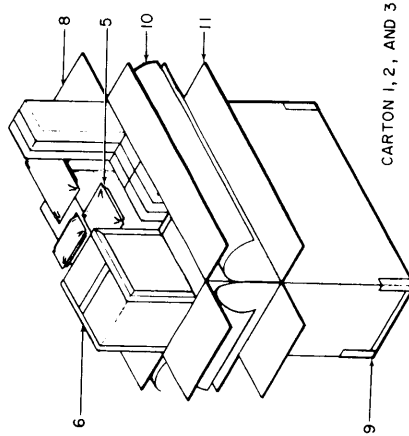

CARTON 1, 2, AND 3

DETAIL B

DETAIL A AND B IN SHIPPING CRATE

Figure 2-3. Typical Equipment Packaging (Sheet 1 of 4).

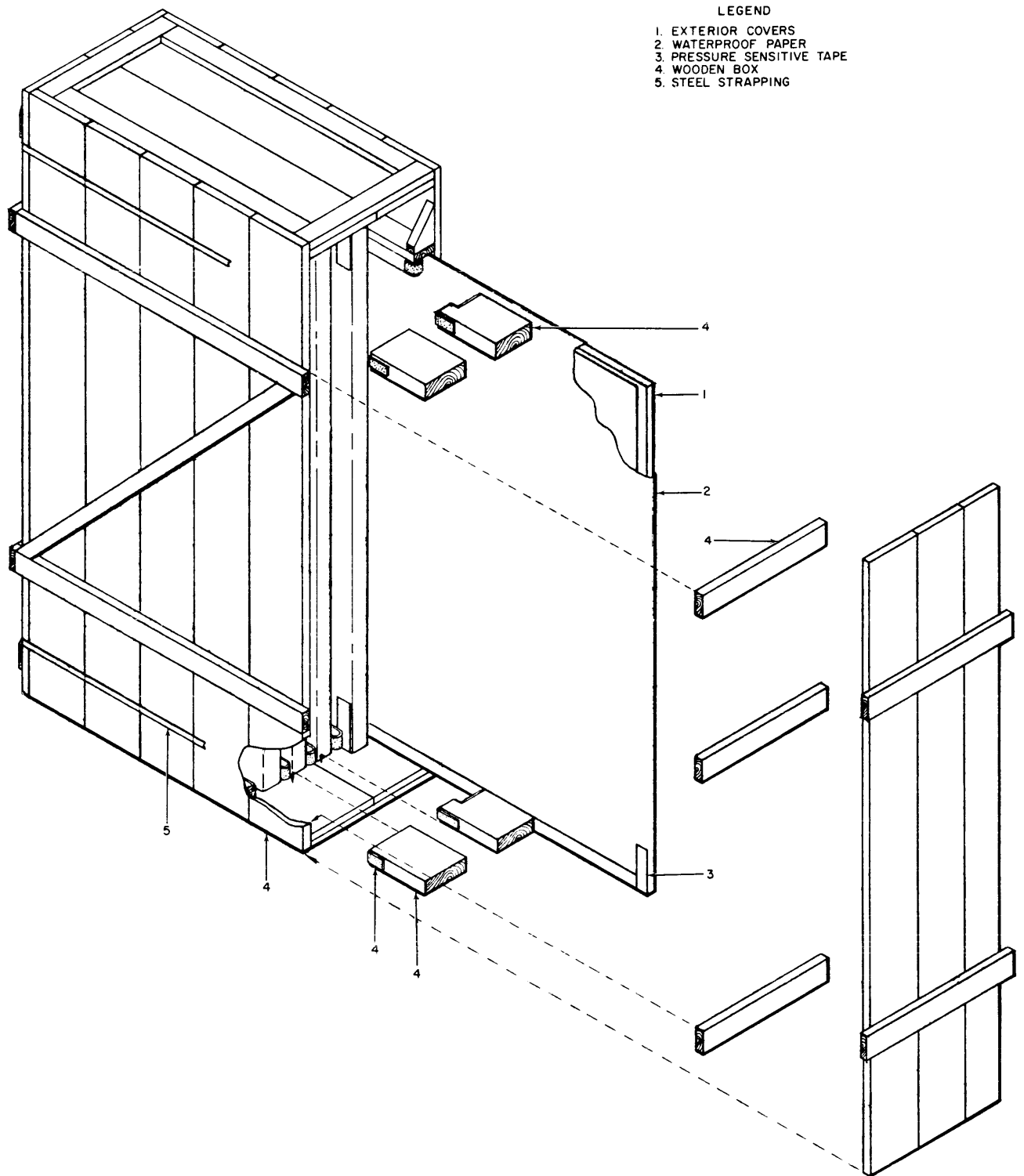

Figure 2-3. Typical Equipment Packaging (Sheet 2 of 4).

- LEGEND
- 1 MAIN FRAME GPT-40K
 - 2 DESICCANT
 - 3 WRAPPING PAPERBOARD
 - 4 PRESSURE SENSITIVE TAPE
 - 5 FACE PANEL
 - 6 BARRIER BAG
 - 7 END CAP CUSHION
 - 8 END CAP CUSHION
 - 9 WOODEN BOX
 - 10 STEEL STRAPPING

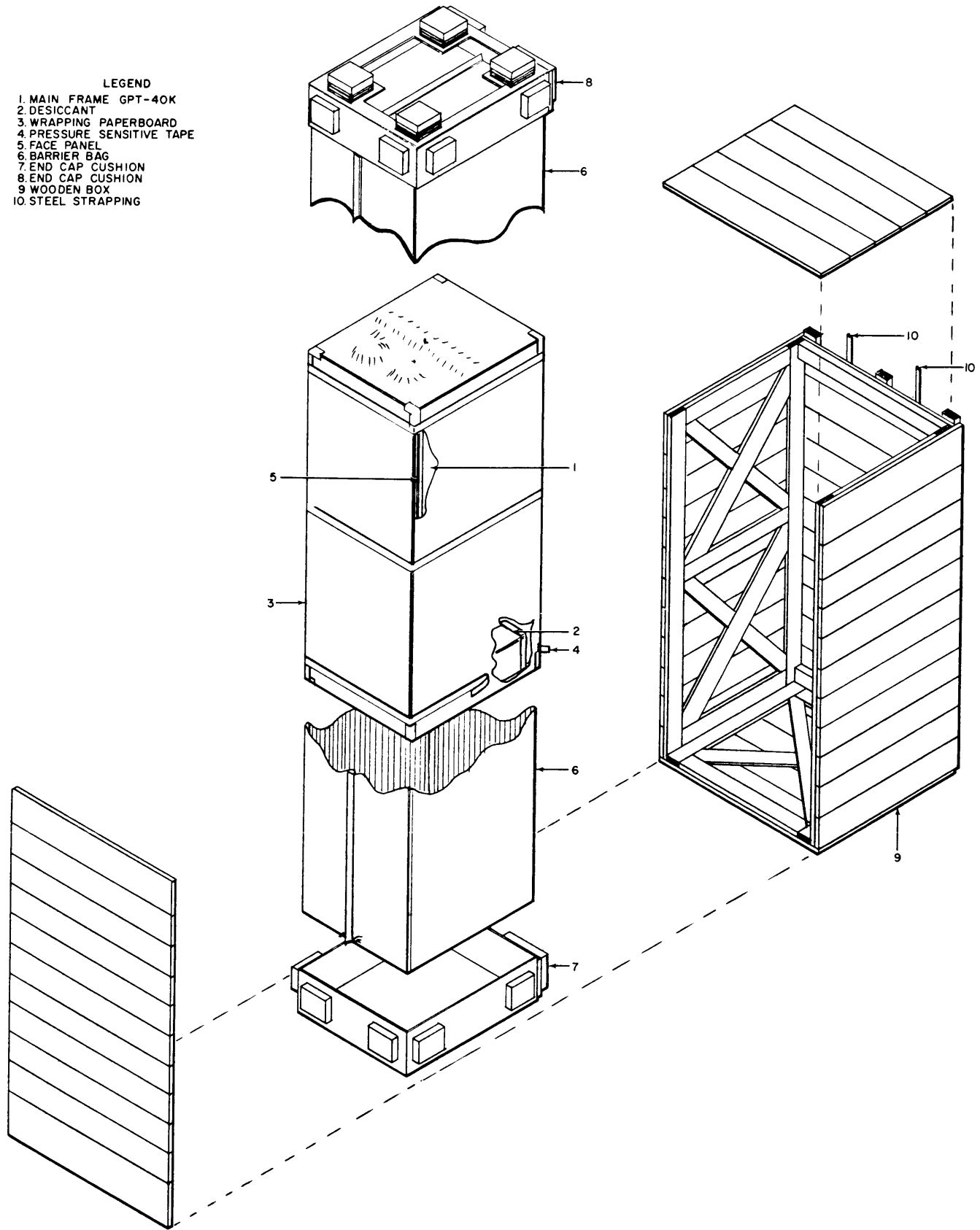

Figure 2-3. Typical Equipment Packaging (Sheet 3 of 4).

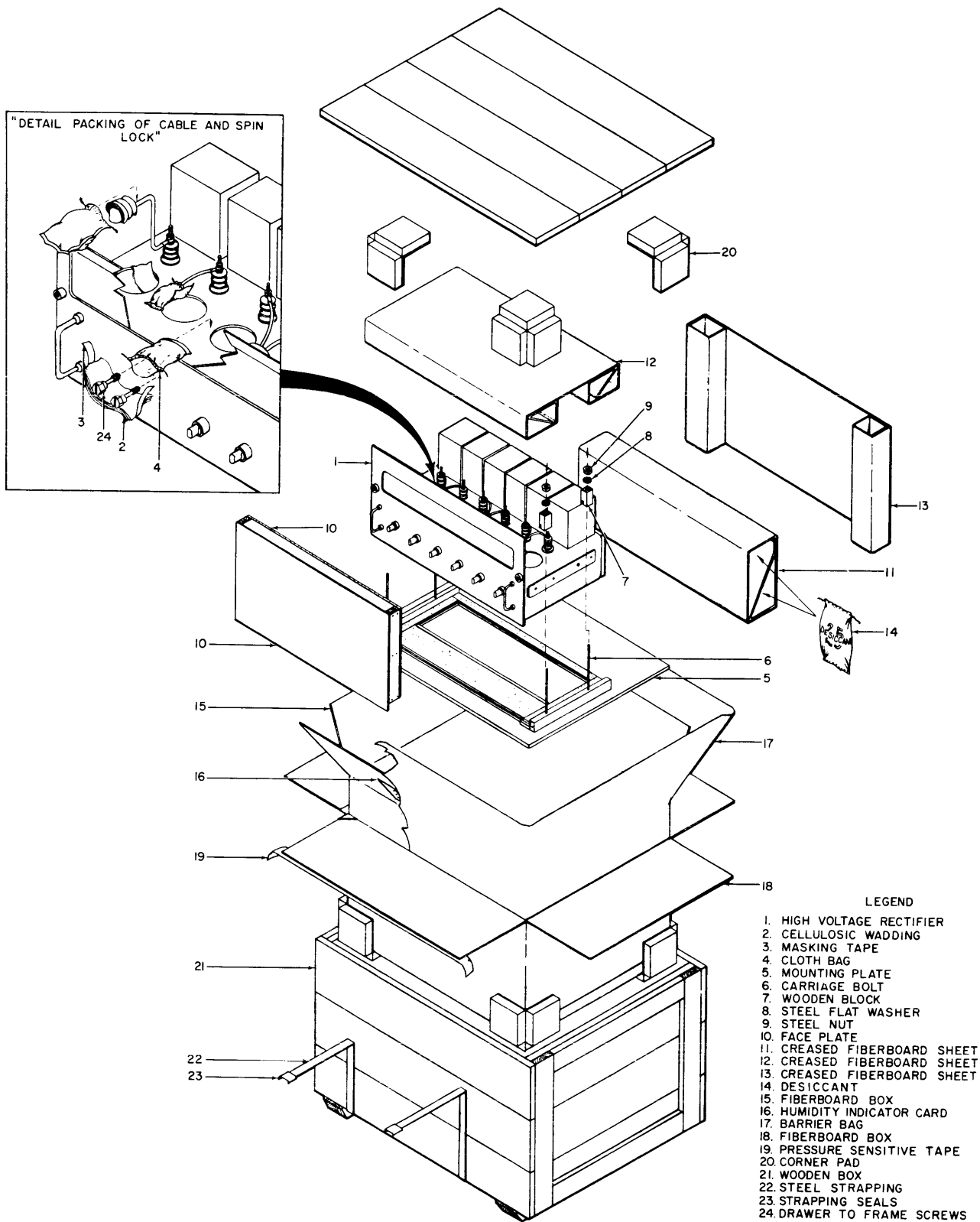

Figure 2-3. Typical Equipment Packaging (Sheet 4 of 4).

Keep in mind the information, previously discussed, on material handling, packaging data and equipment inspection.

a. Remove wire straps or bands from around crates with a pair of snips.

b. Unless otherwise specified, remove nails from three sides of the crates with a nail puller. Do not use a claw hammer, pinch bar, or etc.

c. When the sides of a crate have been removed, the moisture-proof paper must be ripped off. If a knife is used, care should be exercised not to mar equipment.

d. If equipment is not packed in a cardboard carton it may be removed from the crate as prescribed in the installation procedure.

e. If after removing moisture-proof paper a cardboard carton is encountered, carefully open with a case cutter.

f. Where applicable, remove the following:

(1) Creased cardboard blocking pieces.

(2) Barrier bags.

(3) Tape.

(4) Molded cushioning.

(5) Cellulose wadding.

(6) Tissue paper.

g. An inventory of the equipment should be made at this time. As parts are unpacked, they should be marked off on the packing list or equipment supplied list. If anything is damaged refer to paragraph 2-15.

SECTION III

INSTALLATION PROCEDURE

2-17. SCOPE.

A minimum number of assemblies, subassemblies, components and hardware have been disassembled from the 10K transmitter and separately packaged. Thus reducing the possibility of equipment damage in transit. The method of disassembly and separate packaging of the transmitter also permits realistic equipment handling. This section presents logical step-by-step instructions for unpacking the shipping crates containing the transmitter and subsequent assembly.

2-18. GENERAL INSTRUCTIONS.

Carefully read the instructions in each step. After reading, consider the complexity involved in performing the instruction. It may be advisable to simulate a complex step before actually doing it. Make sure each step has been completed before proceeding to the next. Where instructions are not readily obvious, illustrations are provided to complement the procedure.

Cables, wires, and other miscellaneous items that are disconnected during transmitter disassembly are tagged and taped to the equipment. To properly install the transmitter, this tape must be removed as encountered. The information on a given tag indicates the designated terminal on a component to which the tagged item must be connected. Make sure all cables and wires have been connected, as designated on tags, before sealing-up a frame or section

of a frame with an r-f shield, front panel, drawer, or piece of exterior trim (a door, cover, etc.). If any confusion arises regarding cable or wire connections that must be made, refer to the applicable circuit diagram in Chapter 3 of this manual.

Temporary removal and replacement of panels, r-f shields, and component mounting assemblies are specifically called-out in the procedure in order to install various items. To prevent unnecessary removal and replacement, follow the installation instructions. Do not anticipate instructions.

A list of equipment required to install the transmitter is presented in table 1-4. These non-specialized tools are not supplied with the equipment since items should be contained in an equipped maintenance shop. Make sure installation personnel adhere to previously outlined techniques on uncrating and material handling.

2-19. PROCEDURE.

The following procedure is for installing the 10K transmitter. The transmitter may be operated with a balanced or unbalanced output. Refer to the operation and maintenance manuals, see table 1-5, for necessary changes that must be made to operate the transmitter with desired output.

STEP 1

- a. Unpack assorted loose items from crate 1.
- b. Check each item contained against equipment supplied list.

STEP 2

- a. Unpack crate 2.
- b. Remove shield from base assembly, figure 2-4, for the first and second frames. Shield will be replaced later.

NOTE

Make sure the base assembly is correctly positioned. This can be determined by locating access holes on the long side of base assembly toward the intended rear side of the transmitter.

- c. Position base assembly in accordance with pre-installation planning (see figure 2-2).

STEP 3

NOTE

Only part of this step can be performed now. The remaining part of the step (physically bending and routing grounding straps up through shield to respective frame studs and then mounting) must be performed as transmitter assemblage progresses.

Using hardware from crate 1 (bag - Grounding Strap Mounting Kit) bolt grounding straps (contained in crate 1), as indicated in figure 2-5 to the base assembly.

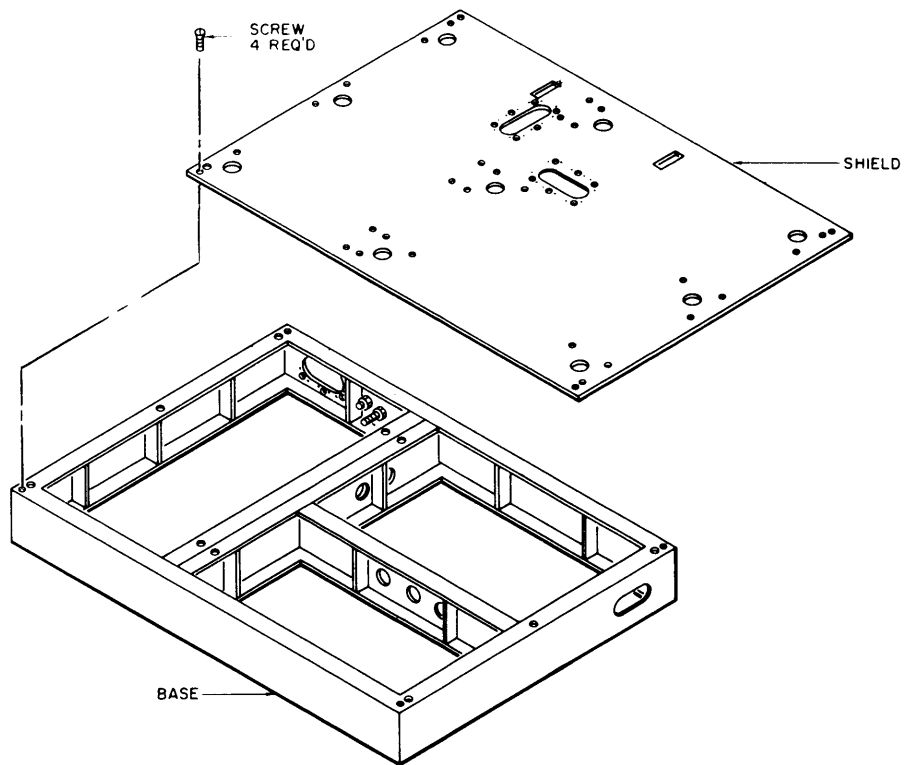

Figure 2-4. Base Assembly for the First and Second Frames, Installation Diagram.

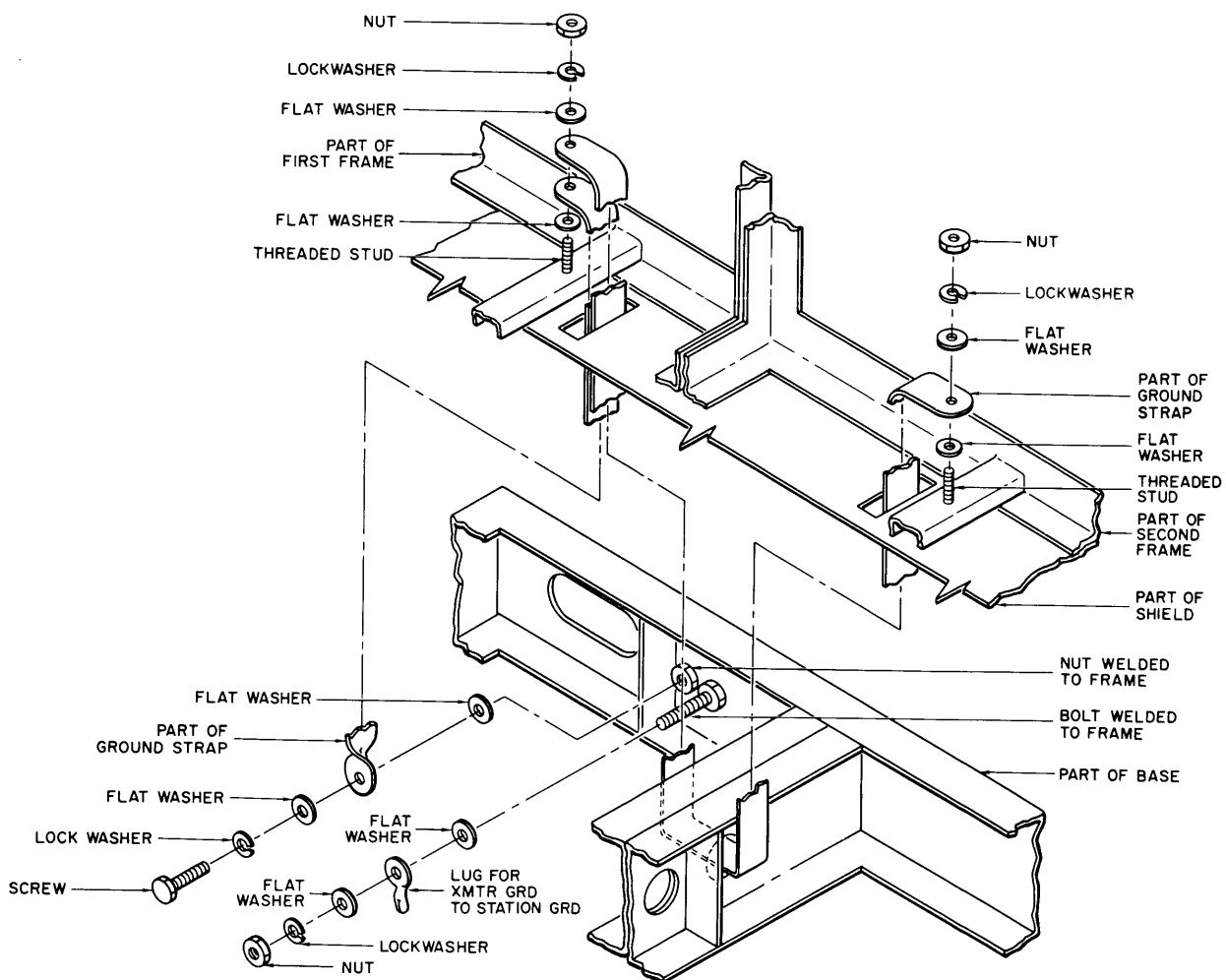

Figure 2-5. Ground Straps, Installation Diagram

STEP 4

NOTES

1. DO NOT connect ac input power cables to the ac input switch box.
2. When connecting cables or wires, make sure cables are connected as indicated in the applicable cable diagram.

Physically route ac input power and input signal cables into base assembly (figure 2-1).

STEP 5

NOTES

1. Grounding straps connected in step 3 must be bent and routed through small rectangular access holes in shield.
2. Ac input power and input signal cables must be routed through appropriate access holes in shield.

- a. Properly position shield, figure 2-4, on base assembly for first and second frames.
- b. Using hardware previously removed, tightly bolt shield to base assembly.

STEP 6

- a. Unpack crate 3.

NOTE

Ground strap coming through shield will be connected later.

- b. Position first frame on base assembly (see figure 2-6).

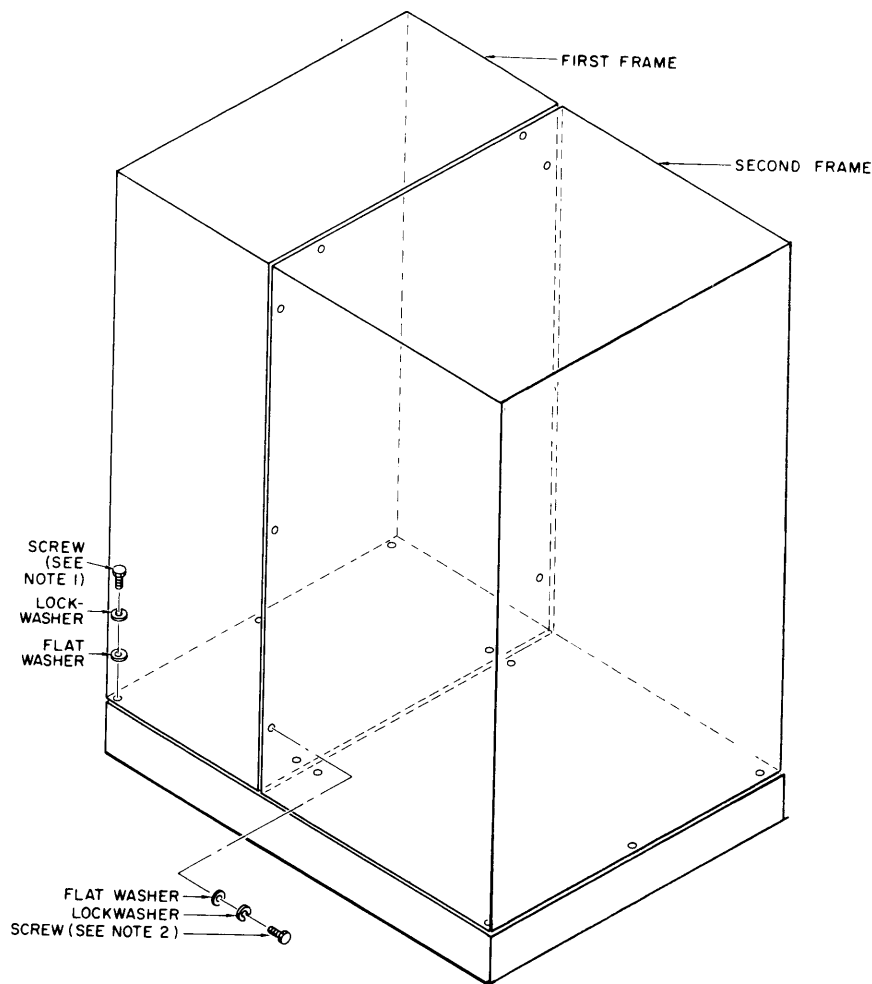

- NOTES
1. FIVE SETS OF HARDWARE ARE REQUIRED TO MOUNT EACH FRAME TO THE BASE ASSEMBLY.
 2. TEN SETS OF HARDWARE ARE REQUIRED TO BOLT FRAMES TOGETHER.

Figure 2-6. First and Second Frames, Installation Diagram.

STEP 7

- a. Unpack crate 4.
- b. Position second frame on base assembly (see figure 2-6).
- c. Temporarily remove the indicator control and relay panel from the bottom front of the second frame. To remove panel:
 - (1) Unscrew large slotted hex-head screws on the front panel
 - (2) Pull panel forward to clear frame.
- d. Temporarily remove the safety cover from the ac input box in the bottom rear compartment of the second frame.

STEP 7 (cont)

e. Using hardware from crate 1 (bag-frame to base mounting kit), loosely bolt first and second frames to base assembly (see figure 2-6).

NOTE

The plastic cable clamp around cable (line filterboard to ac input box) must be mounted to second frame shield. Hardware is provided in line filterboard mounting hardware kit.

f. Using hardware from crate 1 (bag-line filterboard mounting hardware kit), tightly bolt the line filterboard (contained in crate 1) to the shield (first and second frame shield) inside the bottom rear of the first frame, under the fan.

g. Using remaining line filterboard hardware from crate 1, tightly bolt the line filterboard cover support brackets (contained in crate 1) to the frame shield, one bracket above and below the filterboard.

h. Position and secure filterboard cover (contained in crate 1) to filterboard brackets.

i. Route ac input cable, coming through access hole in base shield, to ac input box in bottom rear compartment of second frame, and connect wires. Make sure proper phasing exists when connecting wires.

j. Replace safety cover on ac input box.

k. Mount grounding straps to threaded studs in bottom rear of frames, figure 2-5, using remaining hardware used in step 3.

l. Temporarily remove the shield from the upper rear of second frame.

m. Temporarily remove the glass window panel from the front of the second frame.

STEP 8

a. Using hardware from crate 1 (bag-auxiliary and main frame assembly kit), loosely bolt frames together (see figure 2-6).

STEP 8 (cont)

b. After all hardware is loosely bolted, so that frame assemblies mechanically align, tighten all frame to base and frame to frame hardware.

STEP 9

NOTE

Make sure each resistor is placed in its designated position.

Mount fixed resistors R802 through R816, R819, and R820 (contained in crate 1) on resistor board, figure 2-7, in bottom rear section of second frame.

STEP 10

a. Loosen hardware on retaining strap (figure 2-8).

CAUTION

Pins located inside mounting socket for tube V900 must not be bent. Check pins carefully before attempting to install tube in socket.

b. Observe pins inside the tube socket.

c. Carefully lift tube V900 (contained in crate 1), handles first, up into air duct in top of frame until base of tube clears socket.

d. Carefully lower tube straight down into socket until slight resistance is encountered. Make sure tube is centered in socket.

e. In one motion while firmly grasping tube handles: rotate tube about a quarter of a turn and push tube firmly down into socket. A slight amount of effort may be required to seat tube. Caution should be observed in seating tube so as not to damage pins in socket. Check tube seating, it must be all the way down and centered in tube socket.

f. Tighten retaining strap hardware, so that tube is held securely in place.

STEP 11

a. Rotate front panel PA TUNE, PA LOAD, and OUTPUT BAL controls, on the

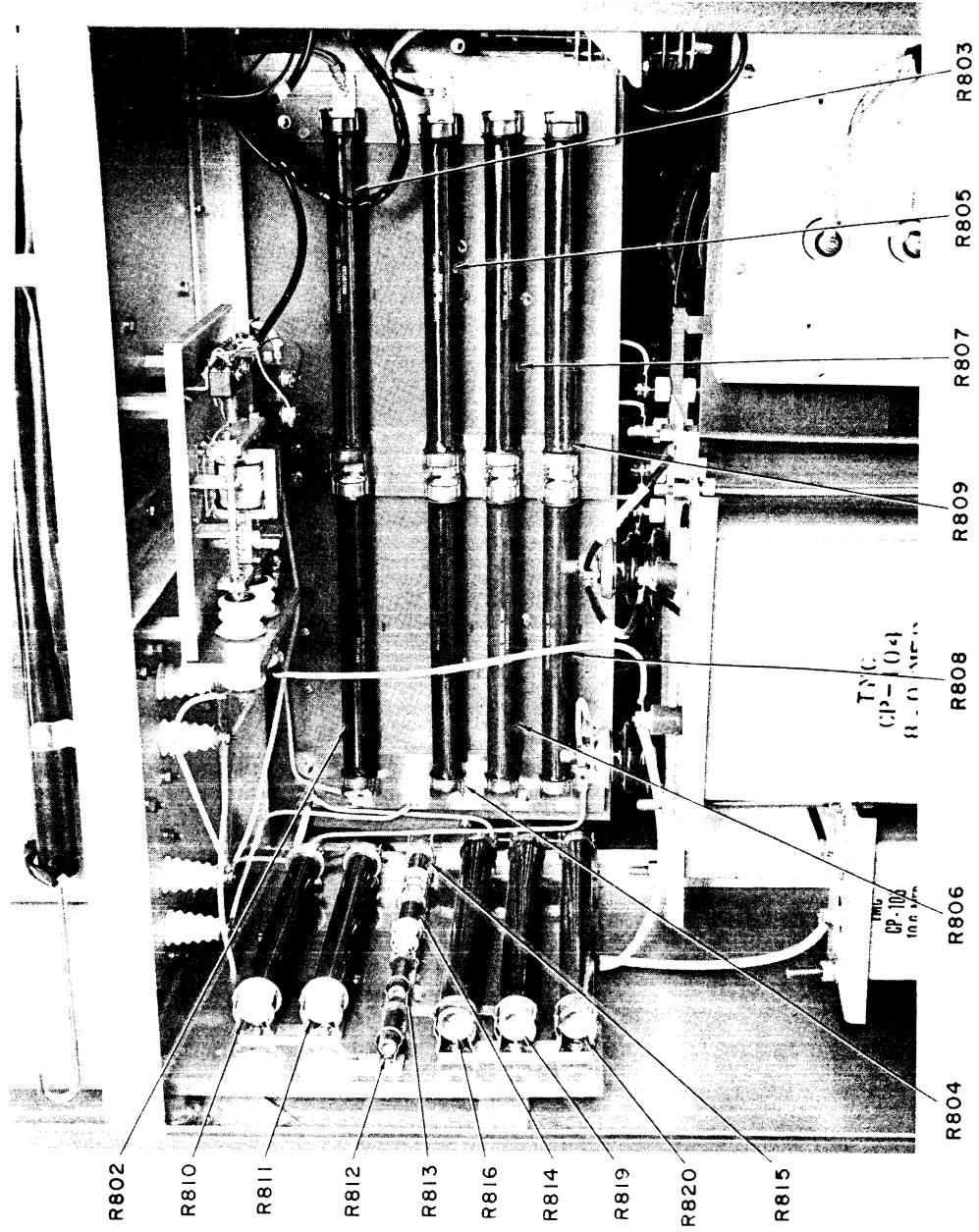

Figure 2-7. Lower Compartment of the Second Frame, Rear View

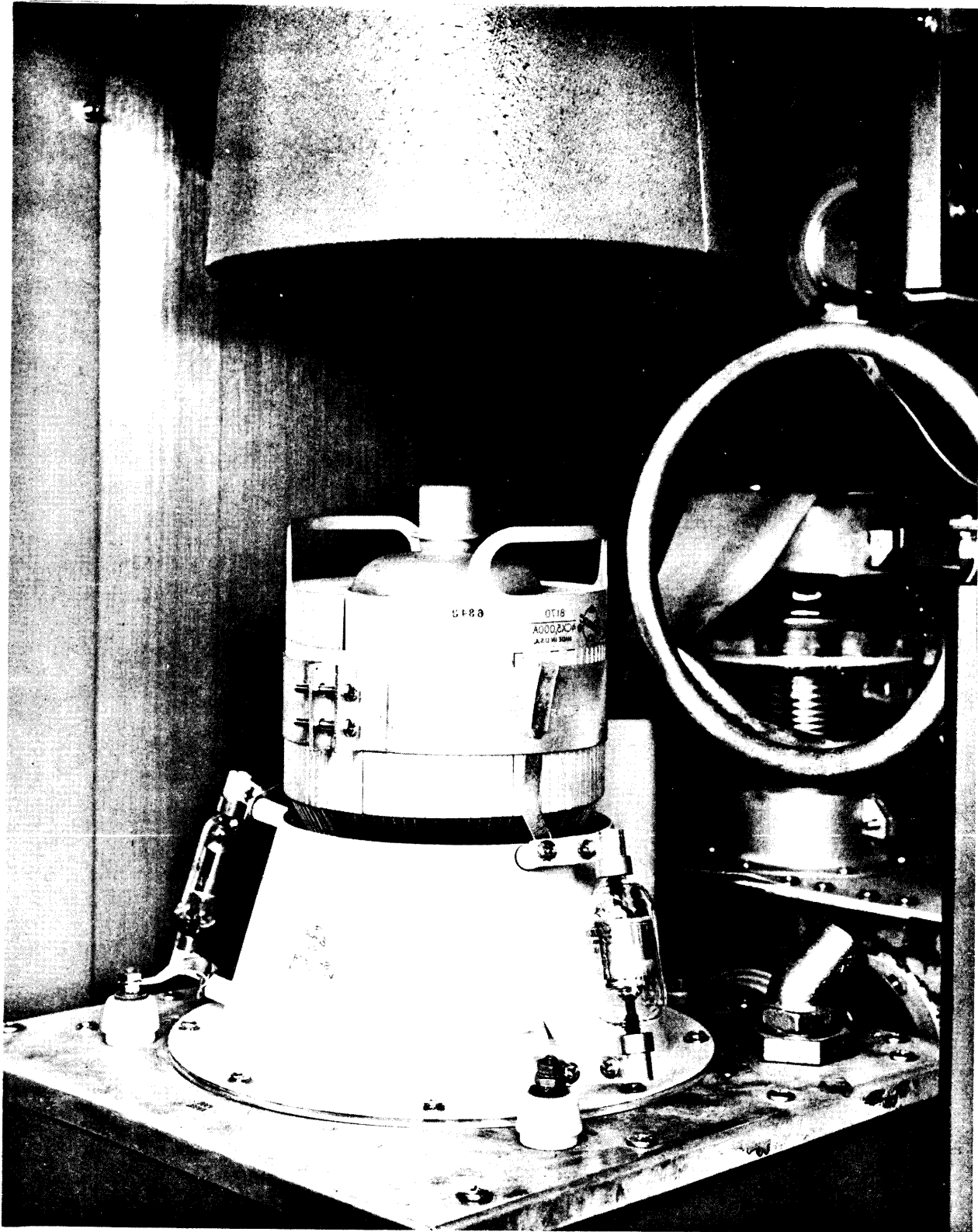

Figure 2-8. Upper Compartment of Second Frame,
Rear View

STEP 11 (cont)

second frame, until corresponding counters indicate "000."

b. Rotate the shafts on variable capacitors C916, C927, and C928 (contained in crate 1) until their plates are fully open (minimum capacitance).

NOTE

Gears on the capacitor shafts
must mesh with gears on front
panel tuning shafts.

c. Install capacitors C928 (PA tune), C927 (PA load), and C916 (output balance), figure 2-9, in their respective flangeclamp mountings. Tighten all retaining hardware.

d. Make the following electrical connections:

- (1) Flange clamp with metal strap, coming from stand-off in front of V900, to the top of capacitor C927.
- (2) Metal straps, coming from the band switch and capacitor C911, to the top center threaded stud on capacitor C928.
- (3) Metal strap, coming from the output load (coil above C916), to the top center threaded stud on capacitor C916.

STEP 12

a. Using hardware from crate 1 (bag-antenna coupler mounting hardware kit), position and mount, figure 2-10, the antenna coupler, (contained in crate 1) in the inside (toward the upper rear) of the second frame.

b. Connect cable CA-829 (part of frame wire harness) plug number 1 to the jack on bottom rear side of antenna coupler DC900 and plug number 2 to the jack on top rear side of DC900.

c. Connect wire from E904 to the threaded stud in the center on the end of DC900 in the frame.

STEP 13

NOTES

1. Hardware on the rods must be temporarily removed to position rod.

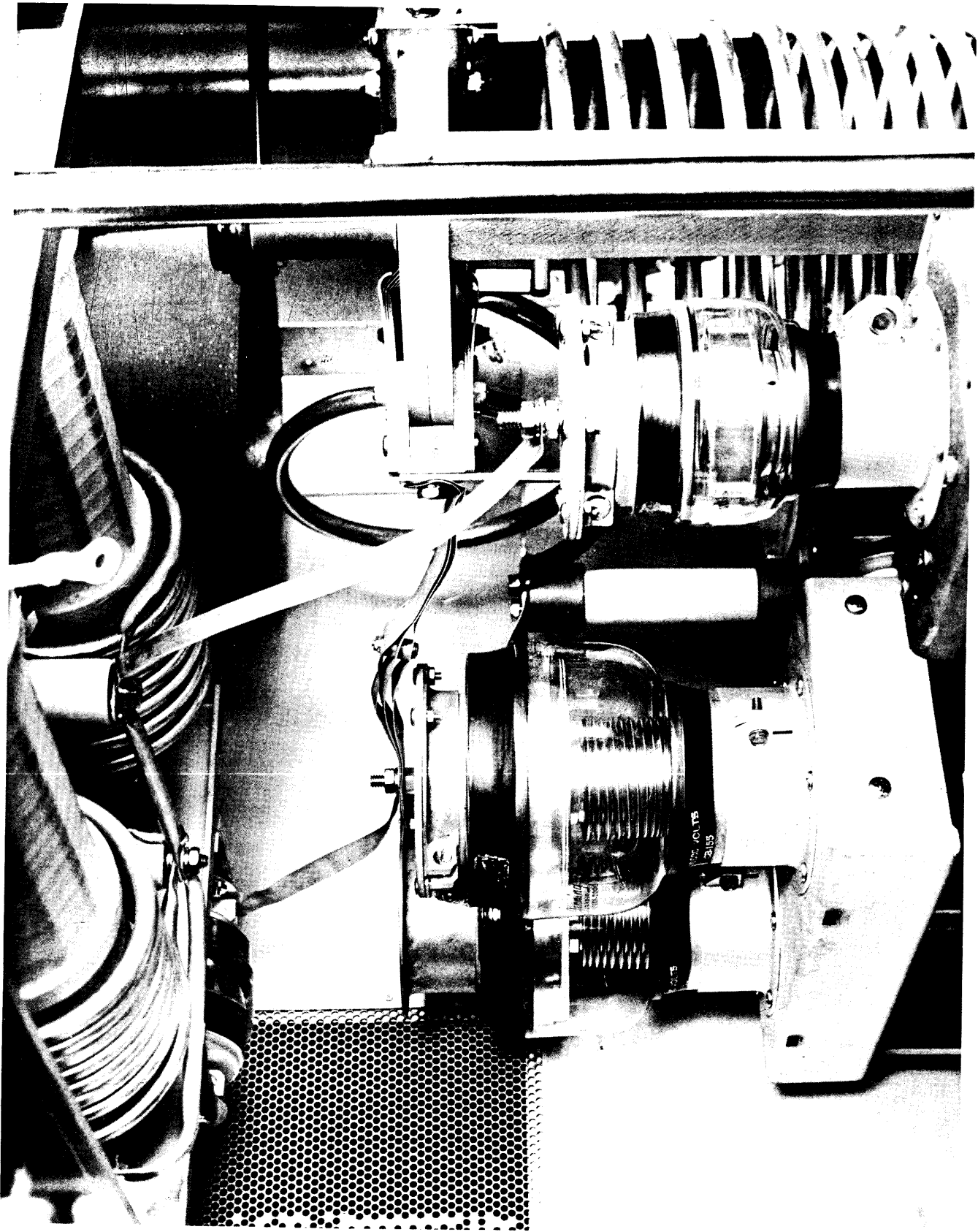

Figure 2-9. Upper Compartment of the Second Frame, Side View

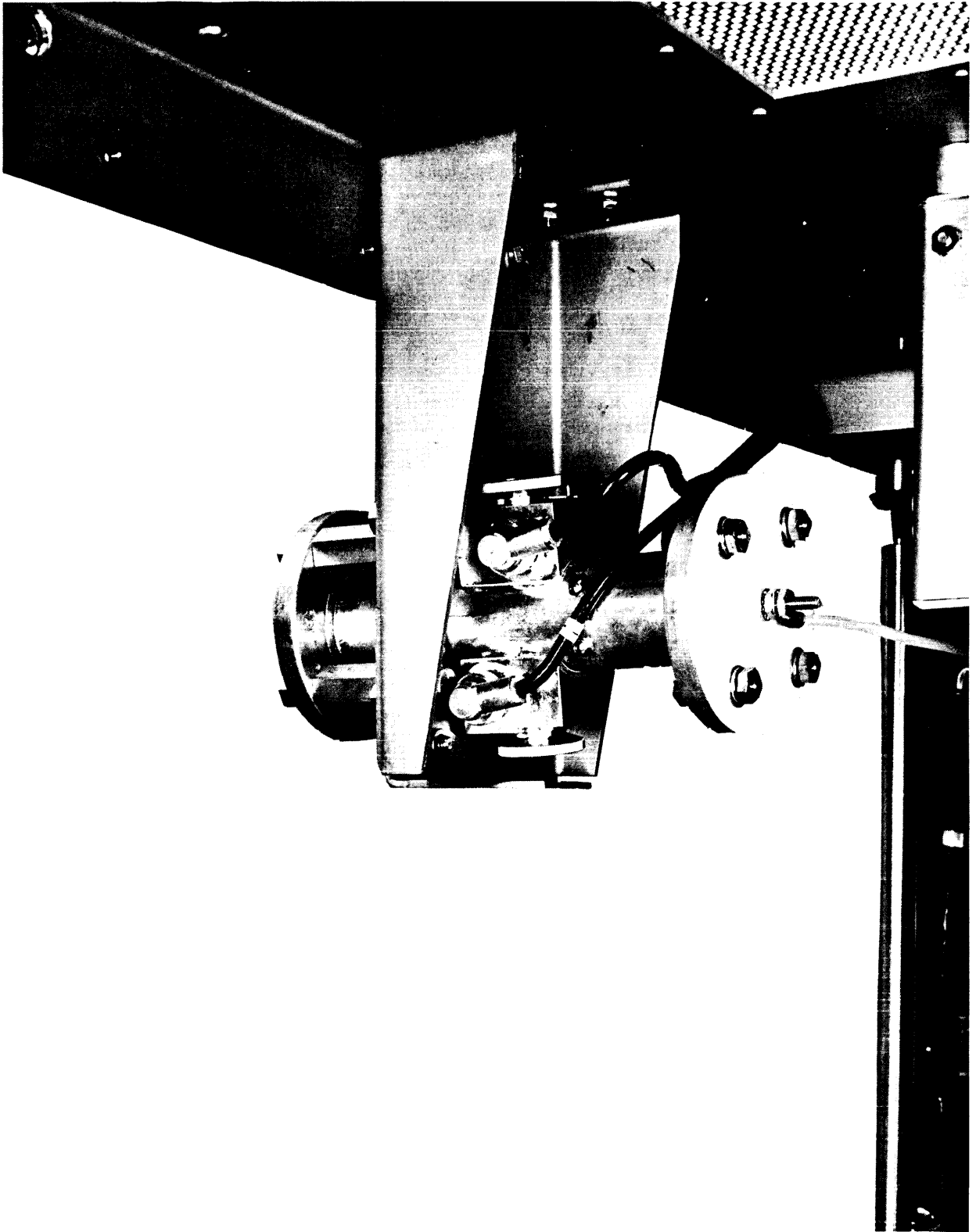

Figure 2-10. Antenna Coupler, Rear View

STEP 13 (cont)

2. Rods must be inserted into bowl assemblies from outside of the frame.
 3. Hardware must be replaced from inside of frame to secure rods in bowl assemblies.
- a. Insert threaded bowl rods (contained in crate 2) into porcelain bowl assemblies, figure 2-11, located on top of the second frame.
- b. Wire transmitter for balanced or unbalanced output as follows:

NOTE

Depending upon desired type of output operation (balanced or unbalanced), the appropriate cable and wire connections must be made. Inside the front of second frame, behind the meter panel is a cabling diagram. Refer to this diagram for desired connections.

(1) BALANCED OUTPUT

- (a) Wire output connection board (behind meter panel) according to diagram, using strap in crate 1.
- (b) Connect two (CA-412) wires, coming from output board to the bowl assemblies.

(2) UNBALANCED OUTPUT

- (a) Remove balanced output connections on output board.
- (b) Make sure wire from E904 is properly connected to DC900 (see step 12c).
- (c) Wire output board as is indicated.

- c. Replace rear r-f shield and front glass window panel on the second frame.

STEP 14

- a. Unpack crate 5.
- b. Position power transformer T800, figure 2-12, into the bottom front of second frame.

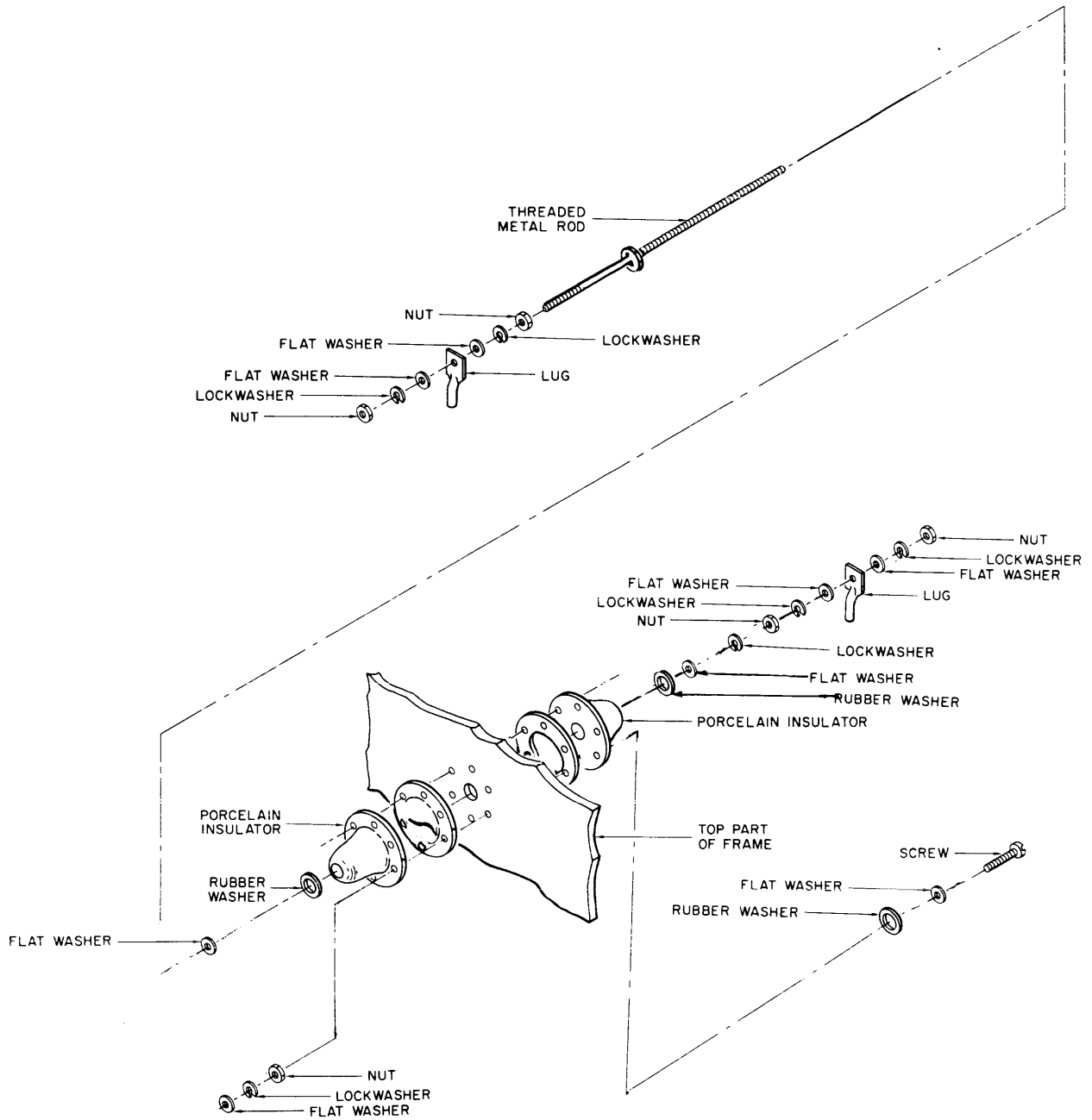

Figure 2-11. Balanced Output Bowl Assemblies, Installation Diagram.

STEP 14 (cont)

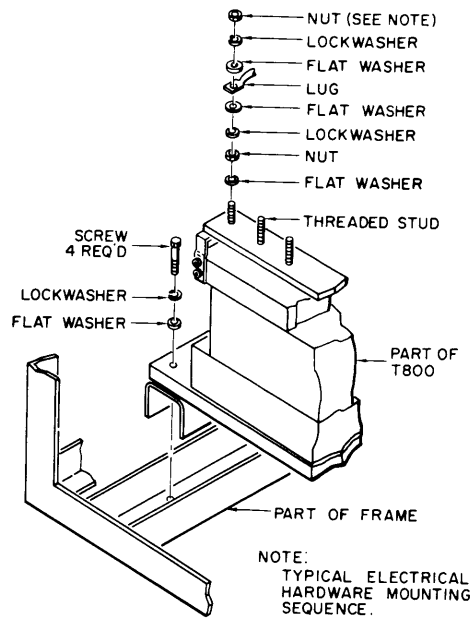

Figure 2-12. Transformer T800, Installation Diagram.

- c. Using hardware from crate 1 (bag-main power transformer mounting kit), tightly bolt T800 to frame.
- d. Connect wires and cables to T800 as indicated in diagram (in chapter 3).
- e. Replace indicator control and relay panel. Make sure two cables in frame are appropriately connected to jacks J700 and J701 on back of the panel.

STEP 15

- a. Temporarily remove safety cover from the filterboard inside the bottom front of the first frame.
- b. Connect wires from relays K3000 and K3001 to filterboard (as indicated in diagram in chapter 3).
- c. Replace safety cover on filterboard.

STEP 16

- a. Unpack crates 6, 7, 8, and 9.

STEP 16 (cont)

NOTES

1. The standing wave control drawer, shipped installed in front of first frame, must be removed and installed in the rear of the frame.
2. Do not install the top three drawers into the front of the first frame. They will be installed after high voltage lamp assembly is installed.

b. Install each drawer assembly in its designated position, figure 2-13, in first frame as it is unpacked. To install any drawer assembly, proceed as follows:

- (1) Untape or unstrap cable assemblies, cable retractors, and all other components secured to the inside of frame for shipment.
- (2) Pull center section of the drawer track out until it locks in an extended position.
- (3) Position slide mechanisms of drawer in tracks; and, ease drawer into track until lock buttons engage holes in tracks
- (4) Where applicable, pull tilt handles on sides of drawer and position drawer vertically.

NOTE

When making cable or wire connections to drawer, secure cables or wires with cable clamps, where applicable.

- (5) Make necessary drawer cable and electrical connections as indicated in diagram in chapter 3.
- (6) Pull tilt handles on sides of drawer and re-position drawer horizontally.
- (7) Press lock buttons on track; and, slide drawer completely into compartment.
- (8) Using hardware from crate 1 (bag-equipment mounting hardware kit), secure front panel of drawer to frame

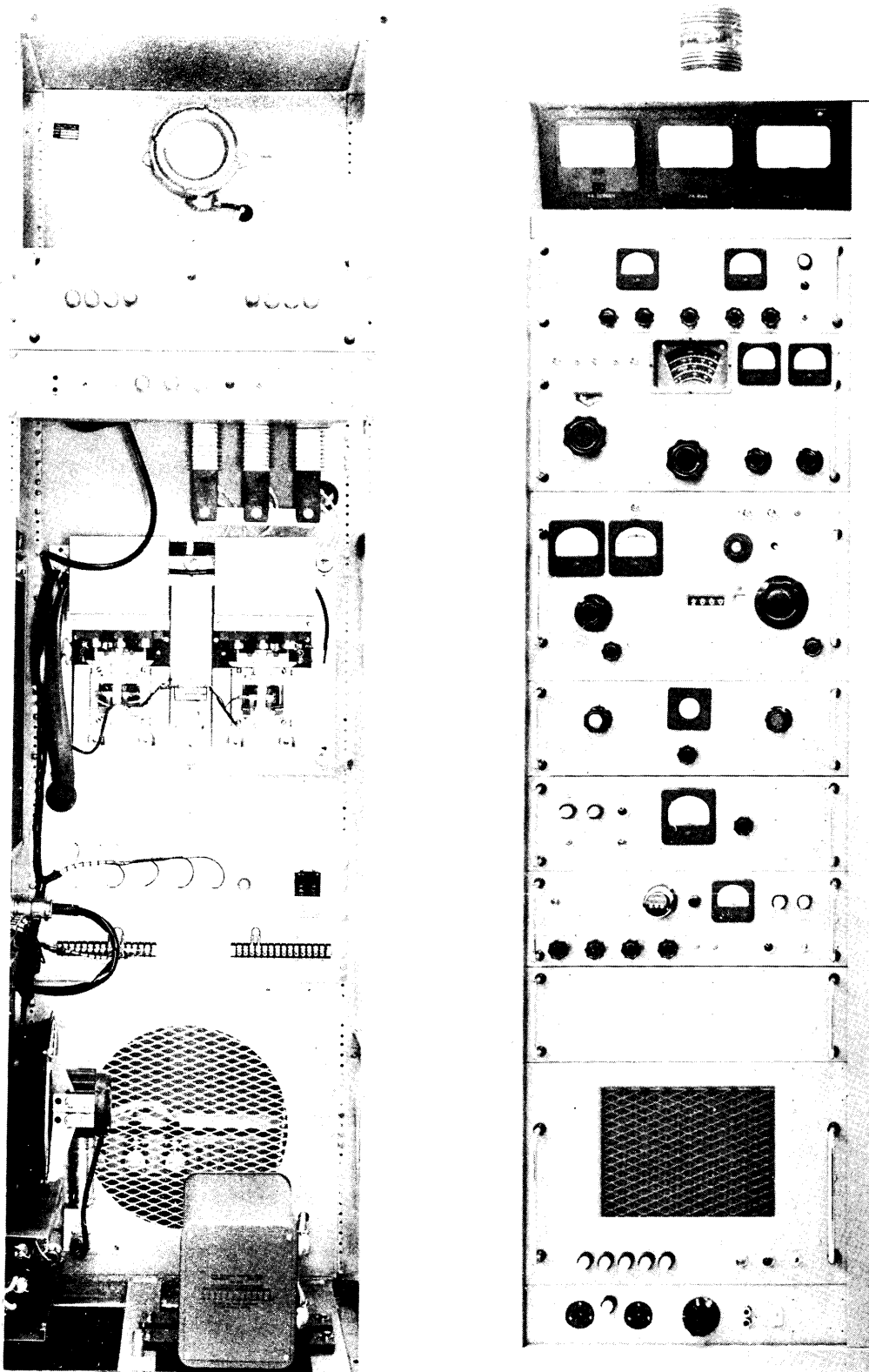

Figure 2-13. First Frame, Front and Rear View.

STEP 17

- a. Unpack crate 10.
- b. Insert six high voltage rectifier tubes V600 through V605 (contained in crate 1), into tube sockets in high voltage drawer (see figure 2-14).
- c. Attach electrical plate connector caps to tubes.

NOTE

To secure the drawer to the frame, tighten two large slotted hex-head screws in the front panel.

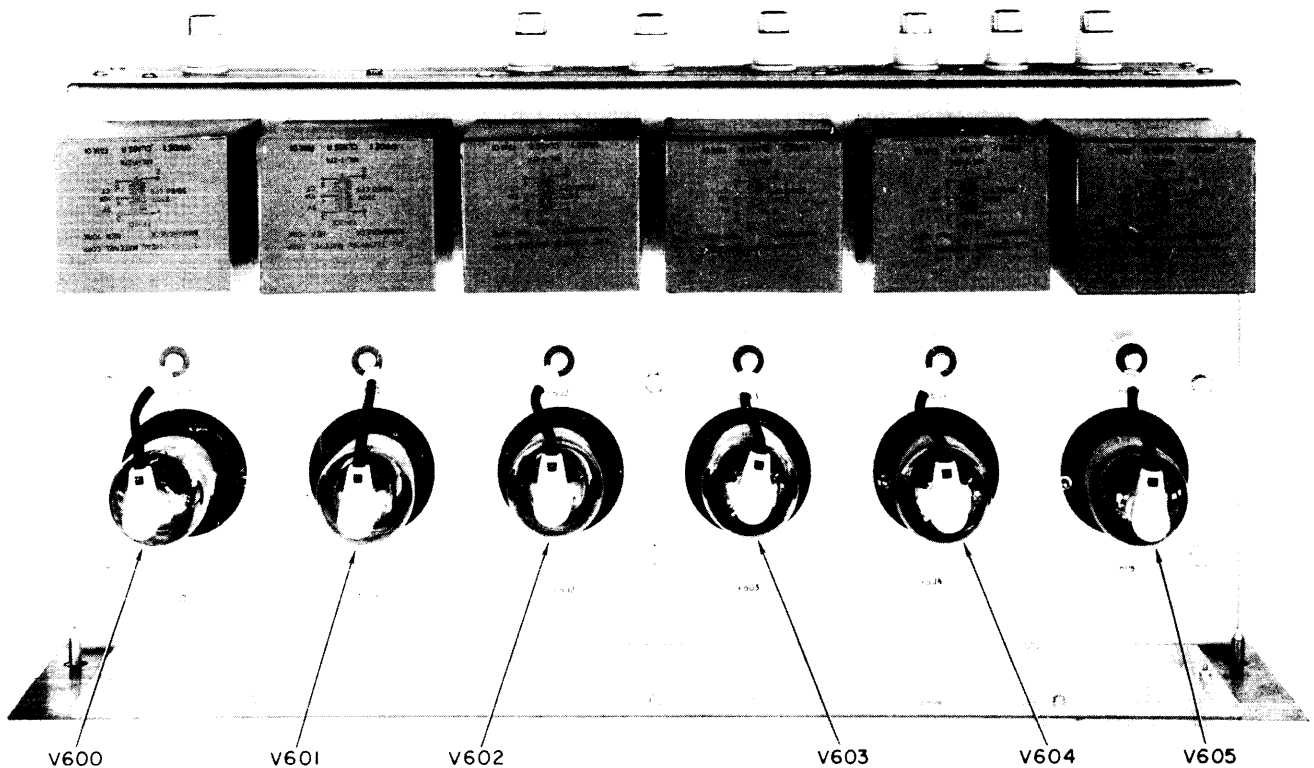

Figure 2-14. High Voltage Rectifier Drawer 600, Top View.

- d. Install drawer into front of second frame.

STEP 18

- a. Unpack crate 11.
- b. Temporarily remove screen cover from top of rfc amplifier drawer.
- c. Loosen screw on retaining strap (see figure 2-15).
- d. Insert tube V203 (contained in crate 1) into tube socket.
- e. Tighten retaining strap screw so that V203 is held securely in place.

STEP 18 (cont)

- f. Replace screen cover on top of drawer.
- g. Install drawer assembly in middle bay of second frame. Make sure cables are connected to rear of drawer (refer to diagram in chapter 3).

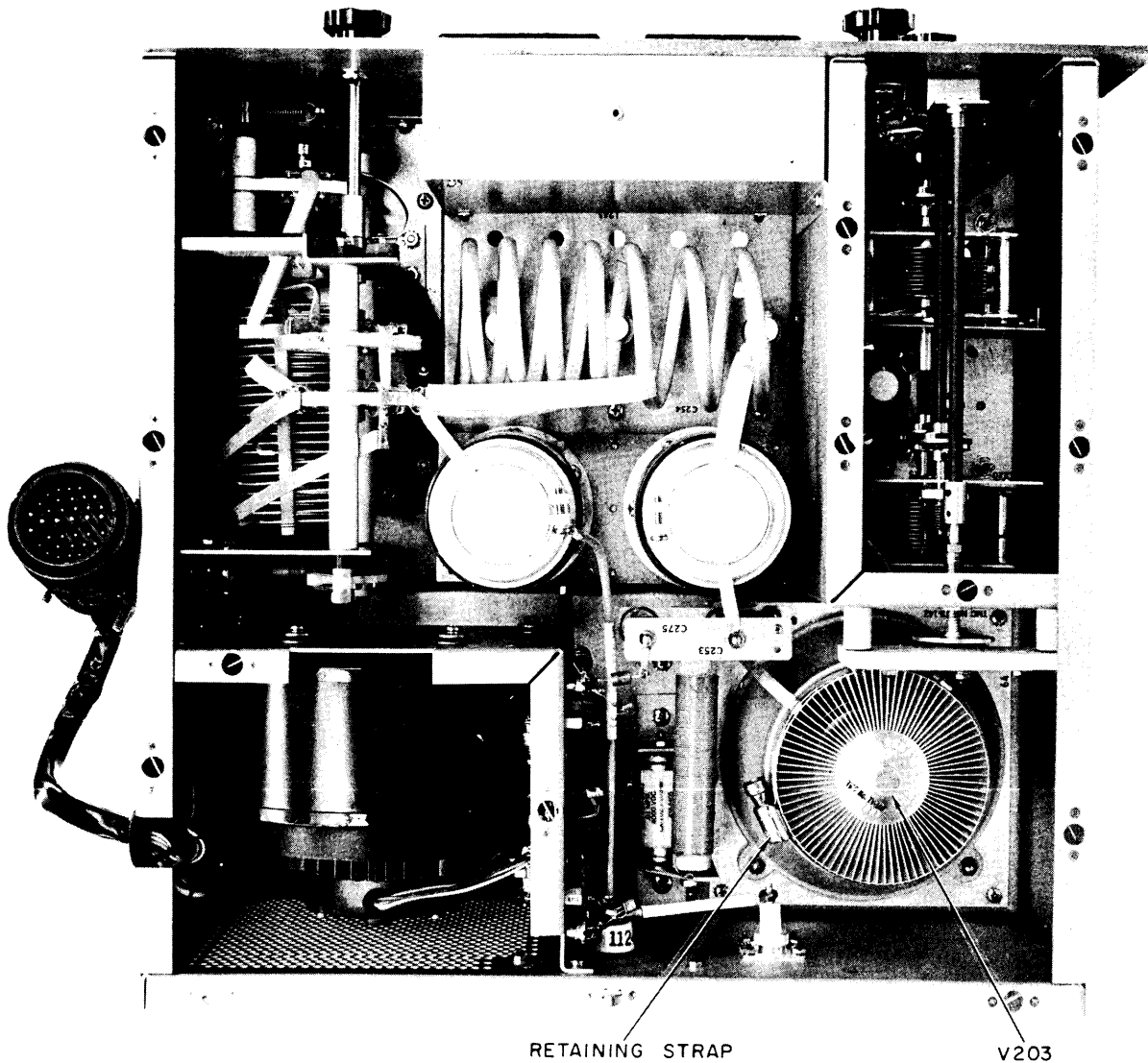

Figure 2-15. RFC Amplifier Drawer, Top View.

STEP 19

- a. Remove the top of crate 12.

STEP 19 (cont)

NOTE

To prevent covers, panels, and doors from being scratched, do not remove from a crate until the item is called for in the procedure.

- b. Check each item contained against the equipment supplied list.

STEP 20

NOTE

If the transmitter is to be operated unbalanced (bowl assemblies not installed) exterior cover plates are provided in crate 1. In this case, mount plate MS-2338 on the top r-f shield over bowl assembly holes; and plate MS-2442 on cover top.

- a. Appropriately position cover top MS-1699 (contained in crate 12) on top of the frames (see figure 2-16).
- b. Using hardware from crate 1 (bag-transmitter top assembly kit), tightly bolt cover top to respective frames.
- c. Insert appropriate size button plugs (contained in crate 1) into cover top to frame mounting holes.
- d. Temporarily remove two sets of mounting hardware from threaded studs on bottom of high voltage lamp socket assembly (contained in crate 1).
- e. Position lamp socket assembly on cover top, above first frame (see figure 2-13).

NOTES

1. The large rubber washer must be placed between socket and cover when mounting.

STEP 20 (cont)

NOTES (cont)

2. The two wire leads coming from the bottom of socket feed through hole in cover and frame; and, connect to terminal board E3003 (mounted inside top of first frame). The white wire to E3003-2. And the white/red wire to E3003-1.

c. Using hardware previously removed from socket assembly, replace on studs inside frame in the following sequence: first, a flat washer; second a lock washer; and third, a nut. Tighten hardware so that lamp socket is held securely in place; do not over tighten.

d. Install remaining three drawers into front of first frame (refer to step 16).

STEP 21

Using hardware from crate 1 (bag-door brackets mounting kit), assemble and mount the following items (contained in crate 1) as prescribe.

- (1) Assemble door latch plates, figure 2-17, to door latch brackets with two phillips flat head screws.
- (2) Mount the resultant door latch assemblies on top and bottom, front and rear, of transmitter (see figure 2-16).

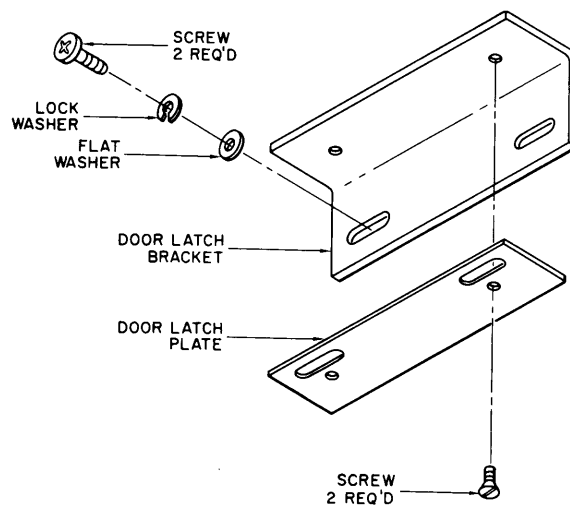

Figure 2-17. Door Latch Plates and Brackets, Installation Diagram.

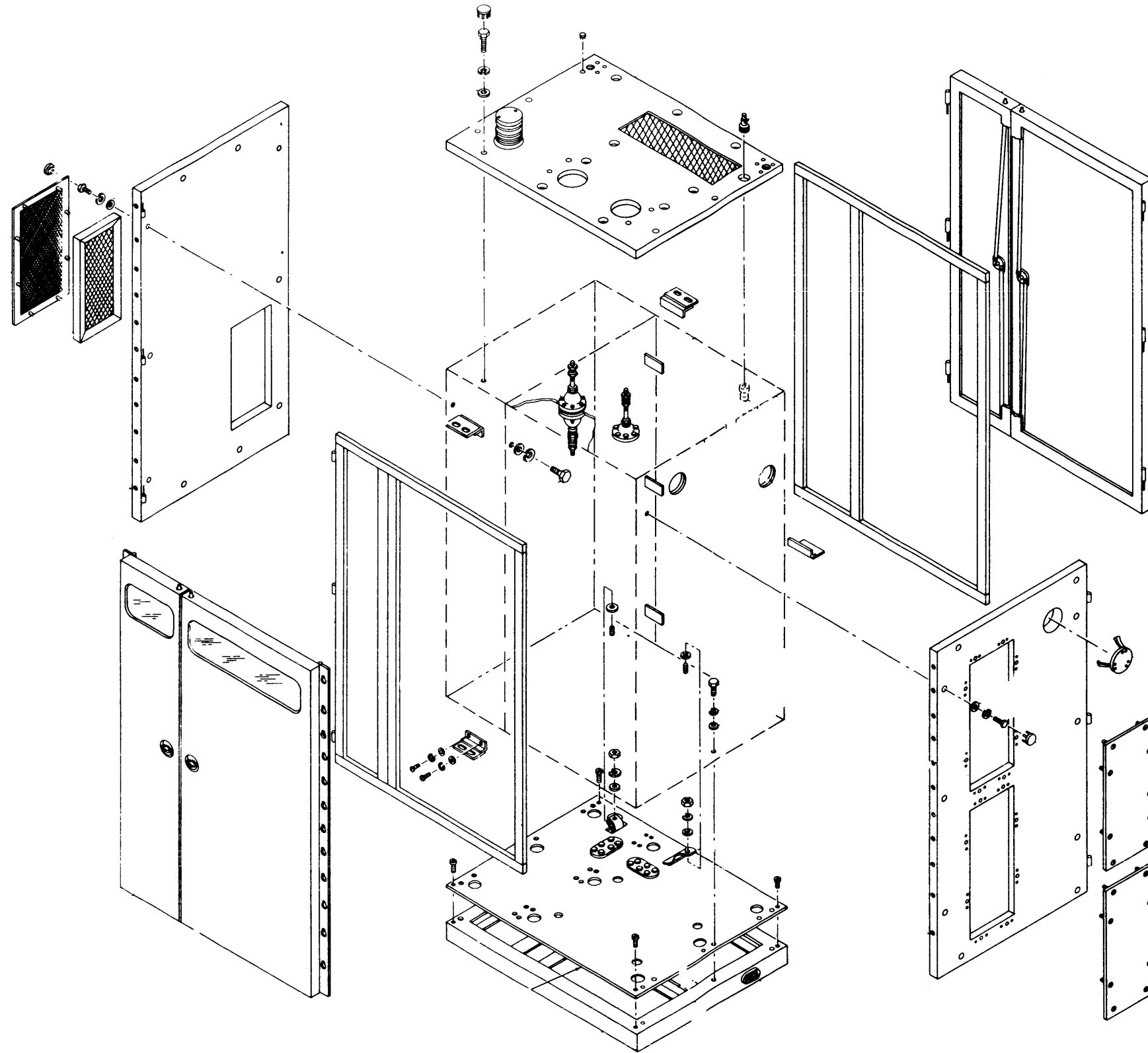

Figure 2-16. Exterior Covers and Trim, Installation Diagram.

STEP 22

a. Using hardware from crate 1 (bag-trim strip mounting kit), push on the tinnerman type clip-nuts onto small "U" shaped brackets welded to front of the first and second frames.

NOTE

Refer to figure 2-16.

b. Using remaining hardware from step 22a, mount the following items (contained in crate 12) to respective frames as follows:

- (1) First and second frame front top trim strip MS-1635.
- (2) First and second frame front hinged trim strip MS-1634.
- (3) Second frame right front trim strip MS-1633.
- (4) First and second frame rear top trim strip MS-1672.
- (5) First frame rear right side trim strip MS-1670.
- (6) First and second frame rear trim strip MS-1669.
- (7) Second frame rear left side trim strip MS-1671.

c. Using hardware from crate 1 (bag-exterior covers to frame mounting kit), mount side panels MS-2117 and MS-2116 (contained in crate 12) on the side of the first and second frames, respectively.

d. Insert appropriate size button plugs (contained in crate 1) into side panel to frame holes.

e. Mount first frame hinged front right and left side trim strips MS-1637 and MS-1920 (contained in crate 12).

f. Back-out door mounting screws in sides (front and rear) of both side panels. And then, respectively hang the following items (contained in crate 12) on door mounting screws in side panels. Re-tighten screws to hold doors securely.

NOTE

It may be necessary to adjust top and bottom door latch assemblies, so that doors close properly.

STEP 22 (cont)

- (1) First frame front door MS-2119.
- (2) Second frame front door MS-2118.
- (3) First frame rear door MS-1648.
- (4) Second frame rear door MS-1647.

g. Using remaining hardware from step 22 a, mount the following items (contained in crate 12) to respective frames as follows.

- (1) First and second frame front bottom trim strip MS-1636.
- (2) First and second frame rear bottom trim strip MS-1672.

STEP 23

Assemble air ducts and appropriately mount, figure 2-2, on the transmitter.

STEP 24

Connect the antenna transmission line(s) to the transmitter. Operating with an unbalanced output, the transmission line is connected to the standard 3-1/8 inch EIA flange connector on side of the second frame. Operating with a balanced output, the transmission lines are connected to the bowl assemblies on top of the second frame.

STEP 25

a. Inspect the contents of all packing crates that have been opened. Make sure miscellaneous items (technical manuals, test data, tube warranties, extra hardware, emergency output cable, or etc.) have been removed before dispensing with packing material and shipping crates.

b. Any remaining crates are spare parts for the transmitter. These crates may be stored as desired.

CHAPTER 3

CIRCUIT DIAGRAMS

3-1. INTRODUCTION.

This chapter presents all of the circuit diagrams necessary for transmitter installation. Circuit diagrams not directly related to installation may be found in the applicable operations and maintenance equipment manual (refer to table 1-5).

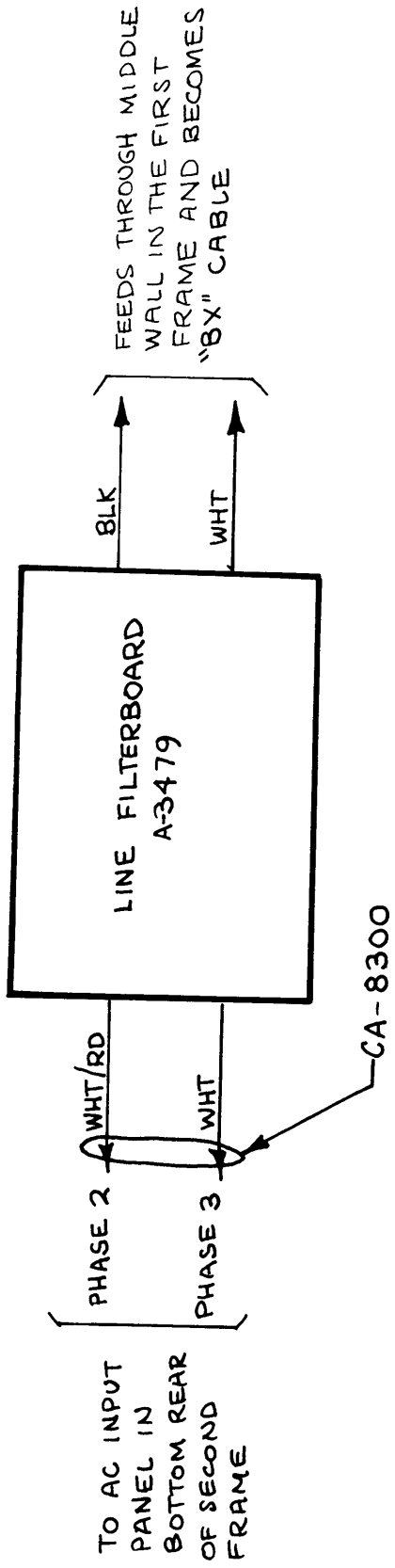

3-12

Figure 3-1. Line Filterboard A-3479, Cable Connection Diagram

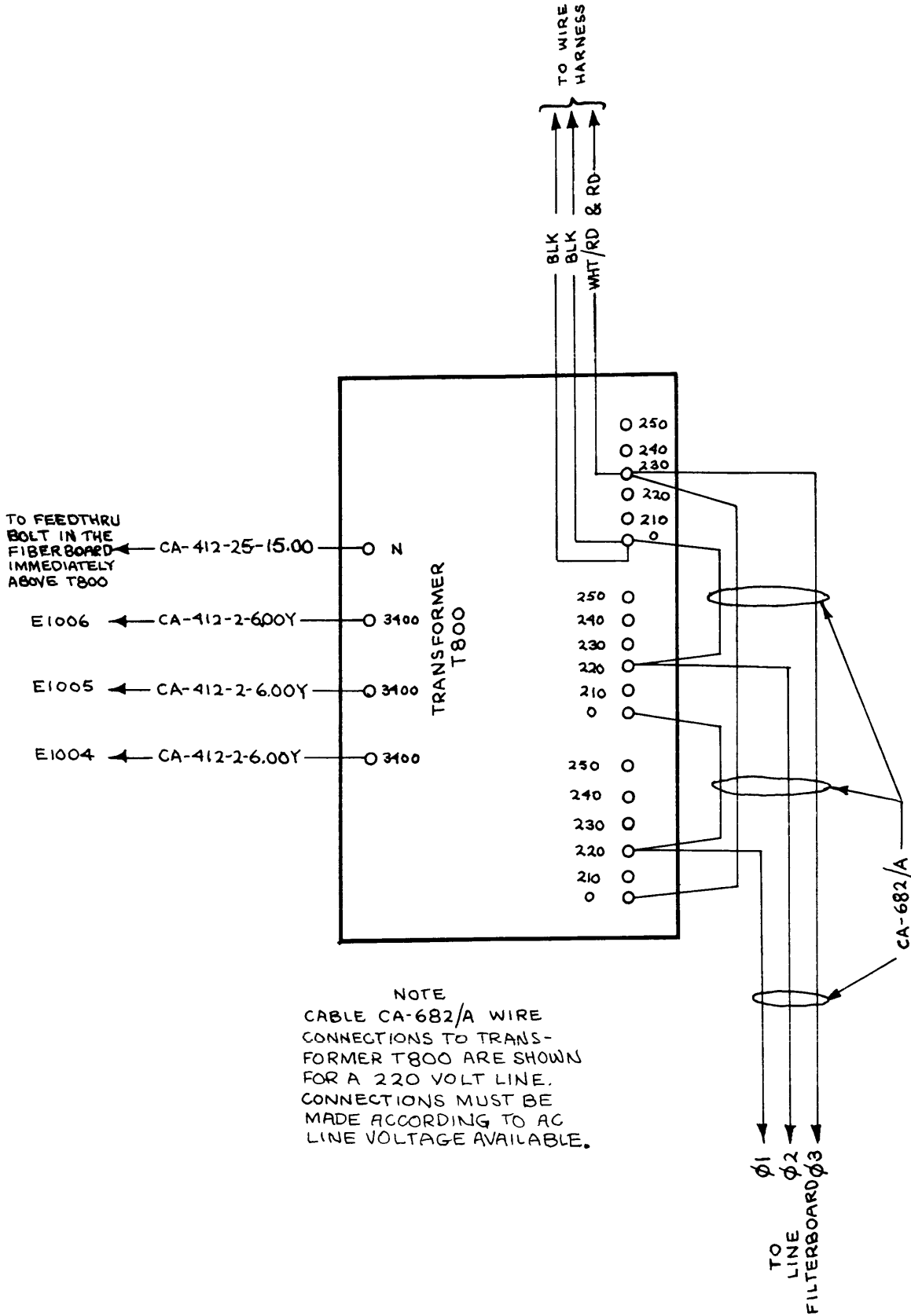

Figure 3-2. Transformer T800, Cable Connection Diagram

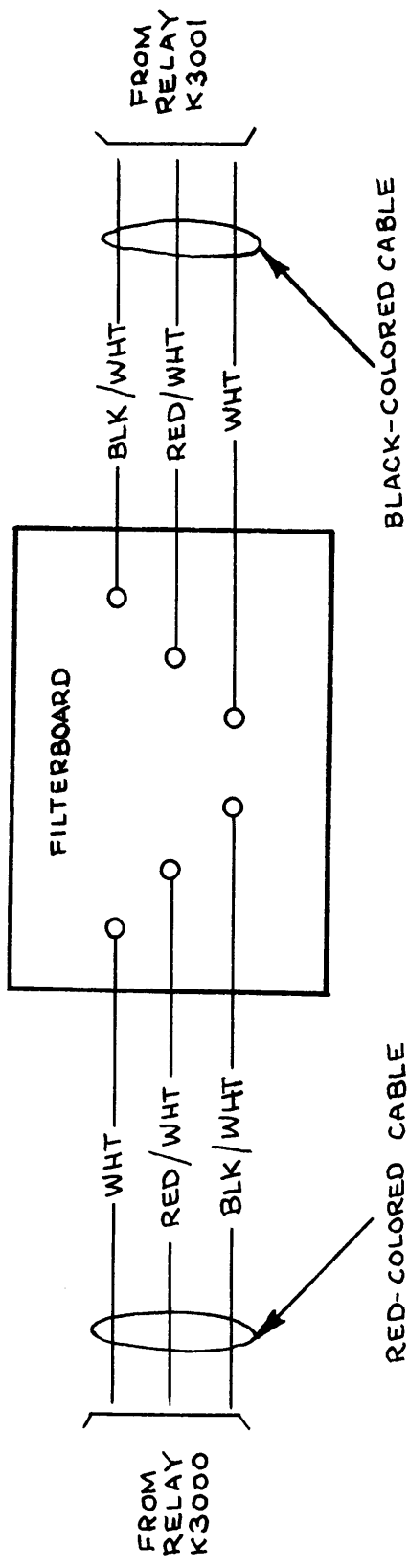

Figure 3-3. Filterboard, Cable Connection Diagram

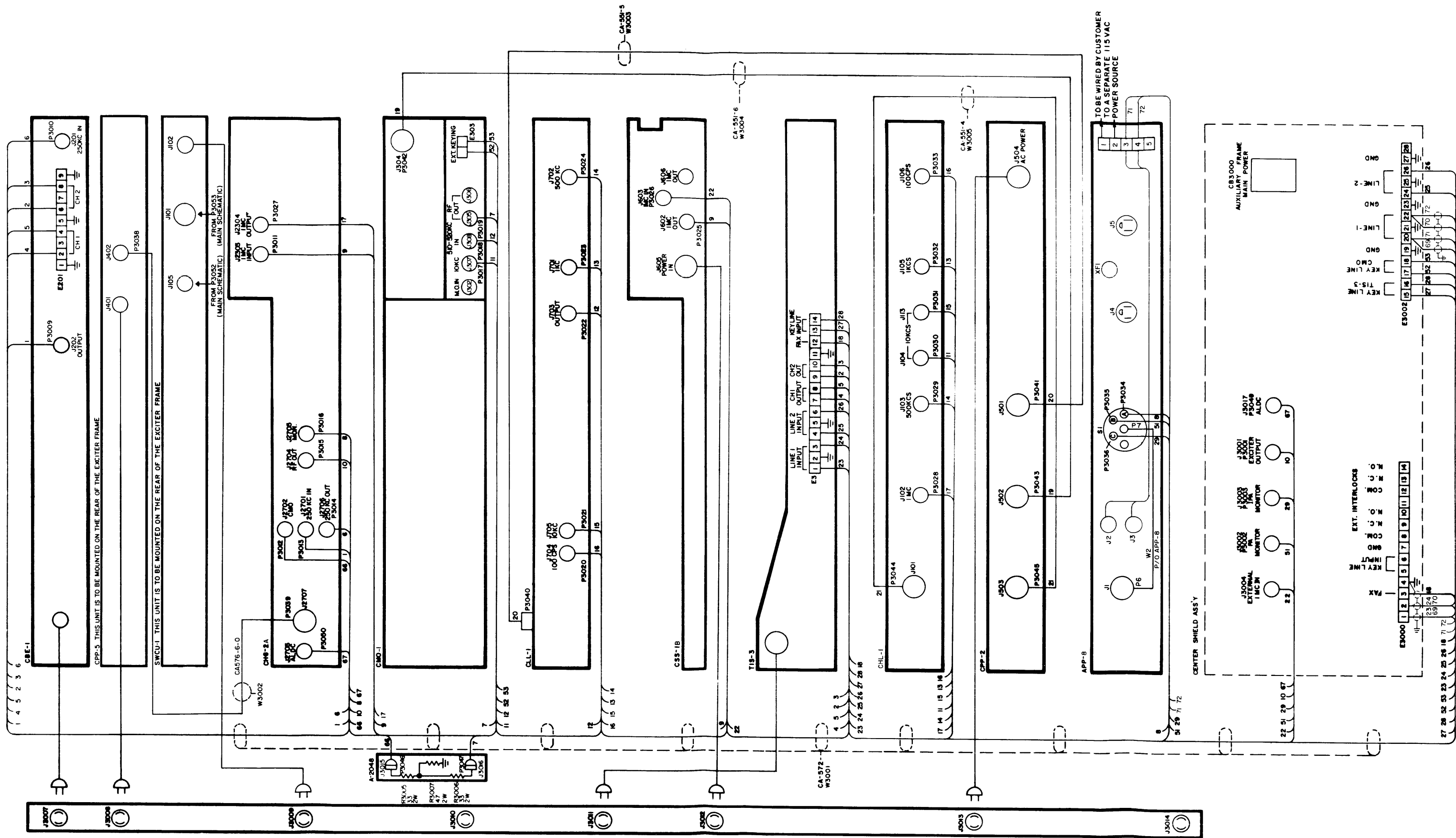
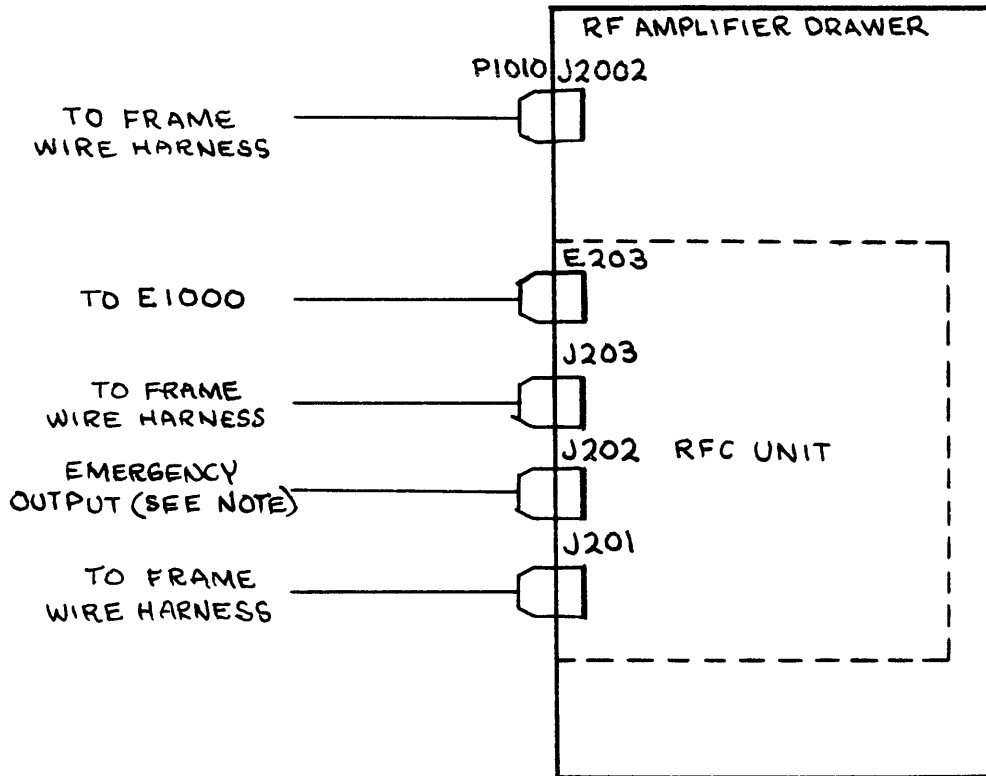

Figure 3-4. First Frame Drawers, Cable Connection Diagram



NOTE
 REFER TO CABLE CONNECTION
 DIAGRAM ON SHELF IN UPPER
 COMPARTMENT OF THE SECOND
 FRAME FOR EMERGENCY OUT-
 PUT CONNECTION TO J202.
 UNDER NORMAL OPERATING
 CONDITIONS, NO CONNECTION
 IS MADE TO J202.

Figure 3-5. Rf Amplifier Drawer, Cable Connection Diagram