

# TECHNICAL MANUAL

FOR

HFLA-1K

HIGH FREQUENCY LINEAR AMPLIFIER

**PUBLICATION NUMBER**

2116-002

**ISSUE DATE**

October 10, 1982

**THE TECHNICAL MATERIEL CORPORATION**

CABLE: TEPEI

700 FENIMORE ROAD, MAMARONECK, NY 10543 U.S.A.  
TEL: 914-698-4800

TWX: 710-566-1100

TLX: 137-358

**TMC (CANADA) LIMITED**

RR No. 5, Ottawa K1G 3N3 Ontario CANADA  
TEL. 613-521-2050

**TMC INTERNATIONAL**

TLX: 053-4146

## NOTICE

THE CONTENTS AND INFORMATION CONTAINED IN THIS INSTRUCTION MANUAL IS PROPRIETARY TO THE TECHNICAL MATERIEL CORPORATION TO BE USED AS A GUIDE TO THE OPERATION AND MAINTENANCE OF THE EQUIPMENT FOR WHICH THE MANUAL IS ISSUED AND MAY NOT BE DUPLICATED EITHER IN WHOLE OR IN PART BY ANY MEANS WHATSOEVER WITHOUT THE WRITTEN CONSENT OF THE TECHNICAL MATERIEL CORPORATION.

## RECORD OF REVISIONS

NO.	ISSUED	DESCRIPTION	ENTERED	BY
001	EMN21995	PAGE 6-3, 7-5/7-6	2-2-83	RU
002	EMN22022	PAGE 6-28, 7-7/7-8, 7-1/7-2	5-9-83	RU
003				
004				
005				
006				
007				
008				
009				
010				

NOTE: Please file Technical Newsletters at back of manual for permanent record.

# Appendix B

## TABLE OF CONTENTS

Paragraph		Page
<u>SECTION 1 - GENERAL INFORMATION</u>		
1-1	Functional Description . . . . .	1-1
1-2	Physical Description . . . . .	1-1
1-3	Reference Data . . . . .	1-2
<u>SECTION 2 - INSTALLATION</u>		
2-1	Initial Unpacking and Inspection . . . . .	2-1
2-2	Power Requirements . . . . .	2-1
2-3	Installation Procedures . . . . .	2-1
2-4	Pre-Operational Checkout Procedure . . . . .	2-7
<u>SECTION 4 - PRINCIPLES OF OPERATION</u>		
4-1	General . . . . .	4-1
4-2	Block Diagram Analysis . . . . .	4-1
4-3	AC Power Distribution . . . . .	4-5
4-4	DC Power Distribution . . . . .	4-9
4-5	Protective Interlocks and Overloads . . . . .	4-12
4-6	ALDC . . . . .	4-15
4-7	Automated Tuning Sequence . . . . .	4-15
<u>SECTION 5 - MAINTENANCE</u>		
5-1	Introduction . . . . .	5-1
5-2	List of Test Equipment . . . . .	5-1
5-3	Operator's Maintenance Procedure . . . . .	5-1
5-4	Preventive Maintenance . . . . .	5-1
5-5	Troubleshooting . . . . .	5-2
5-6	ALDC Adjustment Procedure . . . . .	5-5
5-7	Average Power Level Adjustment Procedure . . . . .	5-6

TABLE OF CONTENTS (continued)

Paragraph		Page
<u>SECTION 5 - MAINTENANCE (continued)</u>		
5-8	Transmitter Bias Adjustment Procedure . . . . .	5-8
5-9	Auto Tuning Adjustment Procedure . . . . .	5-9
5-10	Fault Indication Adjustment Procedure . . . . .	5-15
5-11	Overload Circuit Test . . . . .	5-15
5-12	PA Plate Overload Adjustment . . . . .	5-16
5-13	2nd Amplifier Overload Adjustment . . . . .	5-16
5-14	SWR Overload Adjustment . . . . .	5-17
<u>SECTION 6 - PARTS LIST</u>		
6-1	Introduction . . . . .	6-1
<u>SECTION 7 - MAINTENANCE DRAWINGS</u>		
7-1	General . . . . .	7-1



## LIST OF ILLUSTRATIONS

Figure		Page
<u>SECTION 1 - GENERAL INFORMATION</u>		
1-1	HFLA-1K High Frequency Linear Power Amplifier. .	1-0
<u>SECTION 2 - INSTALLATION</u>		
2-1	Modular Units, Typical Preparation for Shipment.	2-2
2-2	Typical HFLA-1K Installation . . . . .	2-4
2-3	Slide-Mounting Details . . . . .	2-6
<u>SECTION 4 - PRINCIPLES OF OPERATION</u>		
4-1	Functional Block Diagram . . . . .	4-3
4-2	AC Power Distribution . . . . .	4-7
4-3	Operating Potentials . . . . .	4-10
4-4	Simplified Bias Control . . . . .	4-11
4-5	Simplified ALDC Circuit . . . . .	4-13
4-6	Simplified Interlock and H.V. Overload Circuits.	4-17
<u>SECTION 5 - MAINTENANCE</u>		
5-1	Fuse Location . . . . .	5-4
5-2	Auto Tuning Adjustment Control Location . . . .	5-10
5-3	VSWR Nomograph . . . . .	5-18
5-4	AX-5130 Top View . . . . .	5-19
5-5	AP-152 Top View . . . . .	5-20
5-6	AP-151 Top View . . . . .	5-21
5-7	TLAA-1K Top View . . . . .	5-22
5-8	TLAA-1K Bottom View . . . . .	5-23
<u>SECTION 7 - MAINTENANCE DRAWINGS</u>		
7-1	Low Voltage and Bias Supply AP151 Schematic Diagram (CK1870) . . . . .	7-3

LIST OF ILLUSTRATIONS (continued)

Figure		Page
7-2	High Voltage Power Supply AP152 Schematic Diagram (CK1869) . . . . .	7-5
7-3	Power Amplifier TLAA-1K Schematic Diagram (CK1873) . . . . .	7-7
7-4	Servo Control AX5130 Schematic Diagram (CK1883) . . . . .	7-13

LIST OF TABLES

Table		Page
<u>SECTION 1 - GENERAL INFORMATION</u>		
1-1	Major Components . . . . .	1-1
1-2	Technical Specifications . . . . .	1-2
<u>SECTION 2 - INSTALLATION</u>		
2-1	Pre-Operational Checkout Procedure . . . . .	2-8
<u>SECTION 5 - MAINTENANCE</u>		
5-1	Operator's Troubleshooting Chart . . . . .	5-3
5-2	Fuse Functions . . . . .	5-5
5-3	Tube Quiescent Current Values . . . . .	5-9
5-4	List of Servo Tuning Adjustments . . . . .	5-11



Figure 1-1. High Frequency Linear Power Amplifier HFLA-1K

## SECTION 1

### GENERAL INFORMATION

#### 1-1. FUNCTIONAL DESCRIPTION

The TMC Model HFLA-1K (figure 1-1) is an automatically tuned, high frequency linear power amplifier and when used with a suitable exciter provides 1 kilowatt PEP or average power throughout the frequency range of 2.0 MHz to 30 MHz. This linear amplifier, along with a suitable exciter, may be used as the prime source of hf communication, or as part of an existing transmitting system. The small size and light weight of the HFLA-1K makes it readily adaptable for shipboard, aircraft and land installations.

#### 1-2. PHYSICAL DESCRIPTION

##### a. General

As shown in figure 1-1, the HFLA-1K consists of a single equipment cabinet, housing all of the components that make up the HFLA-1K. Table 1-1 lists the major components of the HFLA-1K as they appear in figure 1-1. The HFLA-1K houses a two-stage broad band linear amplifier, power amplifier, associated power supplies, and automatic tuning and control circuitry. Provisions are made to install optional equipments, such as an exciter, antenna tuner and/or a harmonic filter, switchable or fixed.

TABLE 1-1. MAJOR COMPONENTS

<u>TMC Designation</u>	<u>Nomenclature</u>
RF Linear Power Amplifier	TLAA-1K
Servo Control Drawer	AX-5130
Low Voltage and Bias Supply Drawer	AP-151
High Voltage Power Supply	AP-152

##### b. RF Linear Power Amplifier TLAA-1K

The TLAA-1K is slide-mounted in the equipment cabinet and serves as the power amplifier for the HFLA-1K. It contains two broadbanded, low-level rf amplifiers and a final amplifier which provides 1000 watts PEP or average output. The final tube is an 8576 tetrode and is air-cooled by a blower within the TLAA-1K. A front panel plate meter and its associated switch provides constant monitoring of the amplifier plate circuits. Also mounted on the front panel are an OUTPUT meter and associated switch for monitoring forward and reflected power, TUNE and LOAD controls, the BAND switch and associated band indicator lamps, and an ALDC control.

c. Servo Control Drawer AX-5130

The AX-5130 is slide-mounted and contains all of the control and sensing circuitry for automatic tuning of the HFLA-1K. Mounted on the front panel are the HIGH VOLTAGE on/off pushbutton-indicator, the TUNE pushbutton and READY indicator, tuning status indicator lamps, a motorized RF GAIN control, and a POWER LEVEL select control.

d. Low Voltage and Bias Supply Drawer AP-151

The AP-151 is slide-mounted directly above the AP-152. It contains the filament and bias transformer, low voltage transformer, and the overload, bias, and PTT relays. Mounted on the front panel are the SCREEN and PLATE circuit breakers, an INTERLOCKS indicator, the high voltage ALARM and its associated switch, a HIGH VOLTAGE indicator (used also as a combination push-button-indicator switch in certain configurations), and indicator fuses for BLOWER, FILAMENT, LV, BIAS, DC, and CONTROL.

e. High Voltage Power Supply AP-152

The heavy high voltage power supply components are mounted on a chassis and slide-mounted in the base of the equipment cabinet. The AP-152 contains the high voltage transformer, high voltage on relay, and front and rear blower motors. Mounted on the front panel are the MAIN POWER circuit breaker and indicator lamp.

1-3. REFERENCE DATA

Table 1-2 lists the technical specifications of the Linear Power Amplifier, HFLA-1K.

TABLE 1-2. TECHNICAL SPECIFICATIONS

FREQUENCY RANGE:	2.0 MHz to 30 MHz.
OPERATING MODES:	Capable of all standard modes of operation (CW, AM, AME, ISB, SSB, FAX, FSK), but dependent upon the capabilities of the exciter being used with the HFLA-1K.
POWER OUTPUT:	1000 watts peak envelope power or average; continuous key down service.
OUTPUT IMPEDANCE:	50 ohms, unbalanced
STABILITY AND FREQUENCY CONTROL:	Capable of within 1 part in $10^8$ but dependent upon the stability of the exciter being used with the HFLA-1K.
TUNING:	Automatic or manual; automatic has manual override.
RF INPUT:	Provides 1000 watts PEP or average output with an input of approximately 100 milliwatts.

TABLE 1-2. TECHNICAL SPECIFICATIONS (continued)

SPURIOUS SIGNALS:	At least 50 db down from rated PEP output.
HARMONIC SUPPRESSION:	Better than -45 db with reference to full PEP output.
HARMONIC FILTERS:	Available as an option, fixed for all frequencies above 30 MHz or band-switched for lower frequencies.
NOISE:	50 db down; special "white noise" protection.
POWER SUPPLY RIPPLE:	55 db down from full PEP output.
COOLING:	Filtered forced air cooling; semi-pressurized cabinet.
ENVIRONMENTAL:	Designed to operate in any ambient temperature between the limits of 0 to 50°C for humidity up to 90%.
PRIMARY POWER:	115/230 vac, single phase, 50/60 Hz.
POWER REQUIREMENTS:	Approximately 3.75 kilowatts.
SIZE:	The individual components of the HFLA-1K require an approximate rack space of 23"W x 27"D x 49"H. The overall size of the HFLA-1K depends upon the customer selected options and equipment cabinet.
INSTALLED WEIGHT:	The approximate total weight of the individual components of the HFLA-1K is 500 pounds. The overall weight depends upon the customer selected options and equipment cabinet.
COMPONENTS AND CONSTRUCTION:	Manufactured in accordance with JAN/MIL specifications wherever practicable.
SPECIAL FEATURES:	Overload protection and alarm circuitry, controlled and adjustable ALDC, and safety interlocks at all high voltage points.

## SECTION 2

### INSTALLATION

#### 2-1. INITIAL UNPACKING AND INSPECTION

The HFLA-1K Linear Power Amplifier was assembled, calibrated, and tested at the factory prior to shipment. The equipment is shipped in crates as shown in figure 2-1 (typical equipment packaging). The number and contents are stenciled on the outside of each crate. Inspect all packages for possible damage during transit. Carefully unpack each crate as indicated by packing list provided with the linear amplifier shipment. Inspect all packing materials for parts which may have been shipped as loose items (cabinet hardware, connectors, technical manuals, etc.). With respect to damage to the equipment for which the carrier is liable, The Technical Materiel Corporation will assist in describing methods of repair and furnishing of replacement parts.

#### 2-2. POWER REQUIREMENTS

The HFLA-1K requires a single phase source of 115 or 230 vac 50/60 Hz, at approximately 3.75 kw.

#### 2-3. INSTALLATION PROCEDURES

A minimum number of assemblies, subassemblies, components and hardware have been disassembled from the equipment and separately packaged, thus reducing the possibility of equipment damage during transit. The method of disassembly and separate packaging also permits realistic equipment handling.

Carefully read the instructions for each step of the installation procedure. After reading, consider the complexity involved in performing each step; it may be advisable to simulate a complex step before actually doing it. Make sure that each step has been completed before proceeding to the next.

Cables, wires, and other miscellaneous items that are disconnected during equipment disassembly for shipment are tagged and taped to the equipment. The information on a given tag indicates the designated terminal on a component to which the tagged item must be connected. Make sure all cables and wires have been connected as designated on tags and that all packing material, tags and tape have been removed before sealing-up the cabinet or section of the cabinet with a front panel drawer.

Temporary removal and replacement of panels and component mounting assemblies are specifically called out in the procedure in order to install the various items. Do not anticipate instructions; to insure correct installation, perform each step exactly as written.

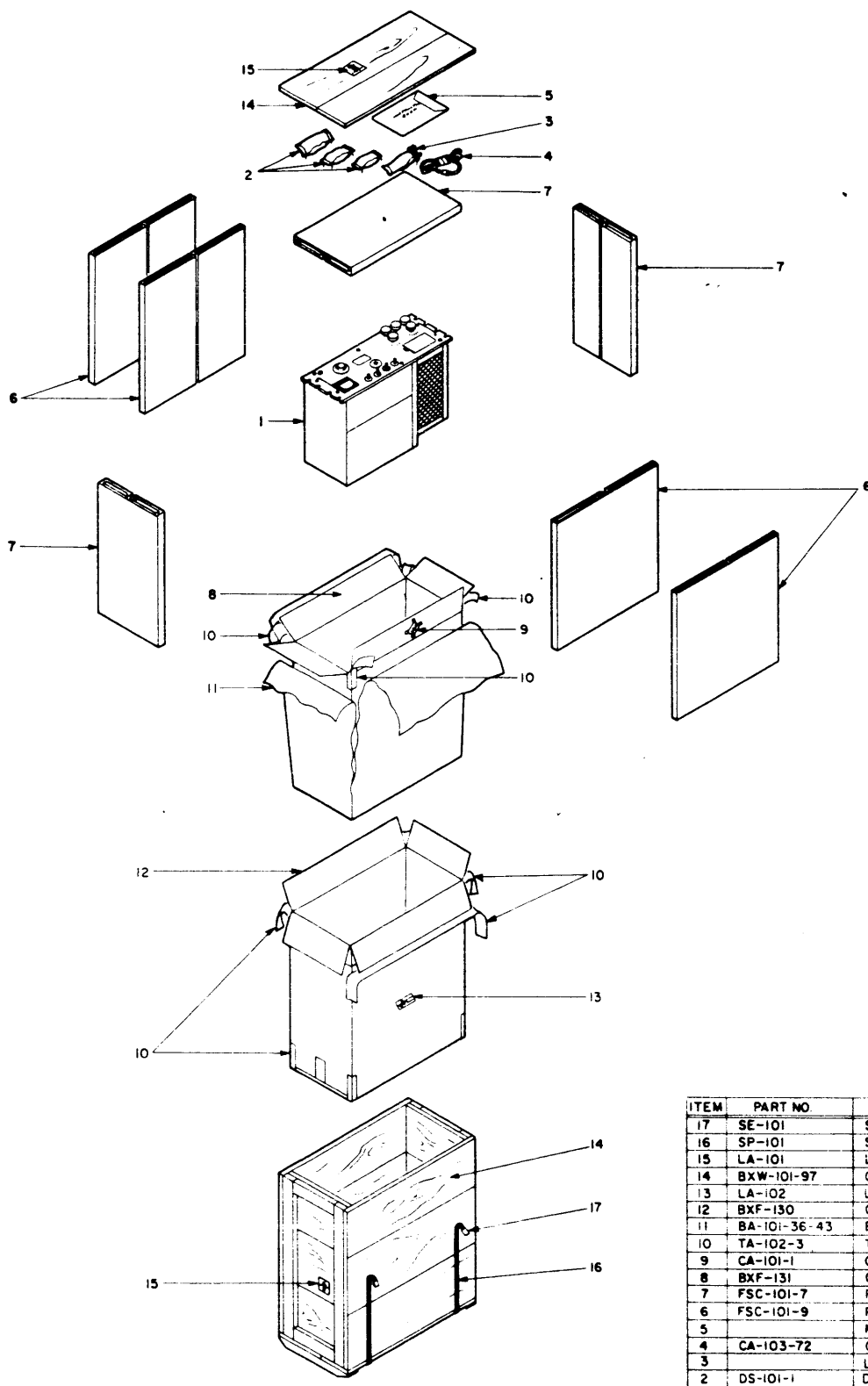

ITEM	PART NO.	DESCRIPTION
17	SE-101	SEALS, STRAPPING
16	SP-101	STRAPPING, STEEL
15	LA-101	LABEL, FRAGILE
14	BXW-101-97	CONTAINER, SHIPPING
13	LA-102	LA-, METHOD II
12	BXF-130	CONTAINER, OUTER
11	BA-101-36-43	BAG, BARRIER
10	TA-102-3	TAPE, PRESSURE SENSITIVE
9	CA-101-1	CARD, HUMIDITY INDICATOR
8	BXF-131	CONTAINER
7	FSC-101-7	FIBERBOARD SHEET, CREASED
6	FSC-101-9	FIBERBOARD SHEET, CREASED
5		MANUALS, INSTRUCTION
4	CA-103-72	CORD LINE
3		LOOSE ITEMS
2	DS-101-1	DESICCANT, 16 UNIT
1		MODULAR UNIT

Figure 2-1. Modular Units, Typical Preparation for Shipment



### NOTE

Refer to the supplied equipment packing list to locate the appropriate crates containing the components, hardware and units outlined in the following steps.

#### STEP 1

- a. Unpack assorted LOOSE ITEMS from crate.
- b. Check each item contained against equipment supplied list.

#### STEP 2

- a. Unpack cabinet from crate, if supplied.
- b. Position cabinet upright (power supply grill located on lower portion of cabinet front indicates upright position), and remove rear panel as necessary (dependent upon equipment cabinet selection). The removal of rear panels on TMC furnished equipment cabinets can be accomplished by turning the screw fastener located at the left and right of the rear panel.
- c. Remove all packing material from cabinet and position cabinet in accordance with pre-installation planning.

### WARNING

INSURE THAT PRIMARY POWER EXTERNAL TO THIS EQUIPMENT IS OFF AND TAGGED.

#### STEP 3 (Primary AC Input Connection)

- a. Route ac input cable to base assembly and connect plug to PWR INPUT jack J2001. (on some models ac input connects to interface panel).

#### STEP 4 (Installation of Power Amplifier Tube, 8576)

- a. Remove the top cover from the TLAA-1K.
- b. Carefully lift power amplifier tube from crate and position it on top of the PA tube socket in the TLAA-1K.
- c. Position tube to line up with PA tube socket contacts.
- d. Carefully lower tube straight down into socket until slight resistance is encountered. Make sure that tube is centered in socket.
- e. Press tube firmly down into socket. A slight amount of effort may be required to seat tube. Caution should be observed in seating the tube so as not to damage contacts in socket. Check tube seating; it must be all the way down and centered in tube socket.
- f. Tighten retaining strap so that tube is held securely in place.

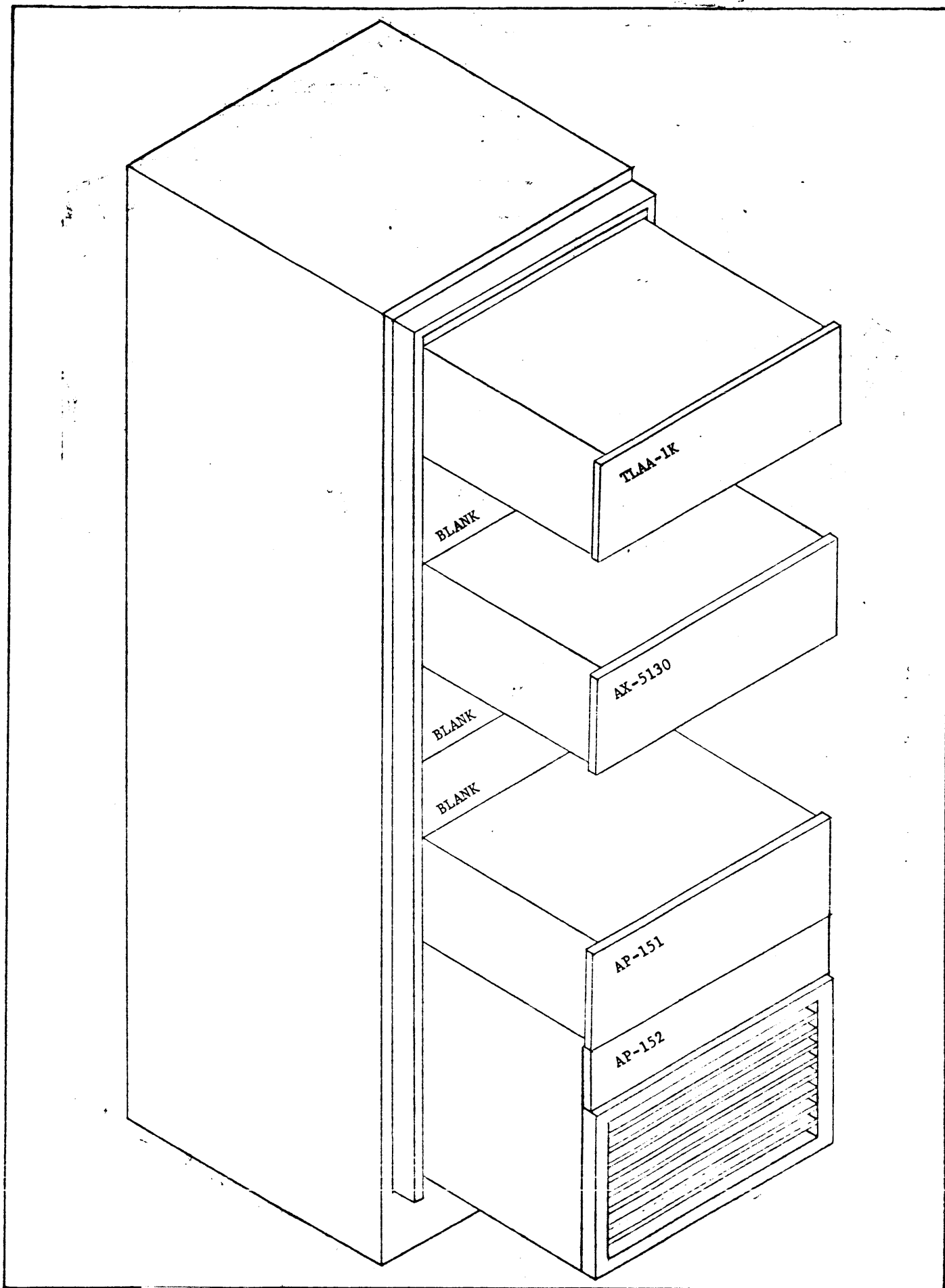

Figure 2-2. Typical HFLA-1K Installation

- g. Replace the top cover of the TLAA-1K and secure it in place.

#### STEP 5

- a. Remove all plug-in relays from LOOSE ITEMS crate.
- b. Install relays in their respective units; plug-in relays are marked for identification and ease in locating their respective sockets.

#### STEP 6 (Installation of Modular Units)

- a. All units in the HFLA-1K are slide-mounted; refer to figure 2-2 for information regarding cabinet location of modular units.
- b. Begin the installation of modular units with the bottom unit (AP-152) and proceed up to prevent the equipment cabinet from tipping over.
- c. Untape or unstrap cable assemblies and all other components secured to the cabinet for shipment.
- d. Refer to figure 2-3 and pull the center section of the associated track out until it locks in an extended position.
- e. Position slide mechanisms of modular unit in tracks, and ease modular unit forward into rack until release buttons engage hole in track.
- f. Make the necessary cable and electrical connections to the modular unit. (Refer to figure 2-4 or system manual for these interconnections and required external connections.)
- g. Depress release buttons and slide modular unit completely into compartment of equipment cabinet.
- h. Secure the front panel of modular unit to the cabinet with hardware provided.
- i. Repeat steps d through h for the installation of each modular unit in the equipment cabinet.

#### STEP 7

- a. Using the grounding hardware supplied, secure grounding strap to the equipment cabinet.
- b. Connect 50 ohm unbalanced antenna, or dummy load, to the output connector of the HFLA-1K.
- c. Affix rear panel to cabinet and secure in place.

#### STEP 8 (High Voltage Transformer Check)

Once the HFLA-1K has been installed and all modular units connected, it is recommended that the ac input to the high voltage transformer be checked. To do this, carefully read the instructions and proceed with extreme caution.

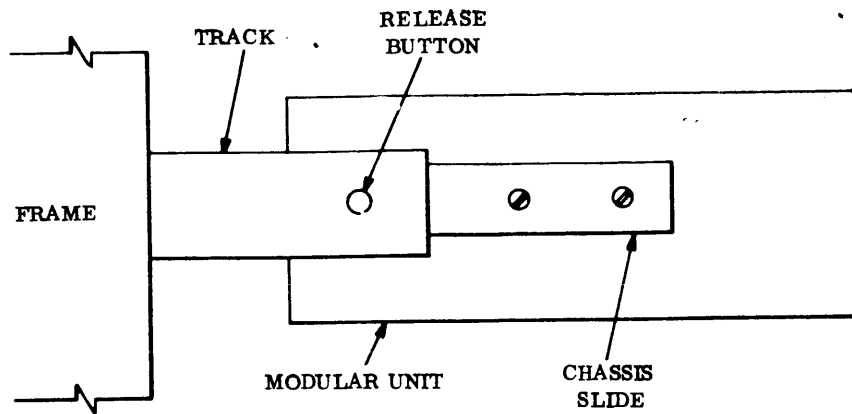

A NON-TILTING SLIDE MECHANISM

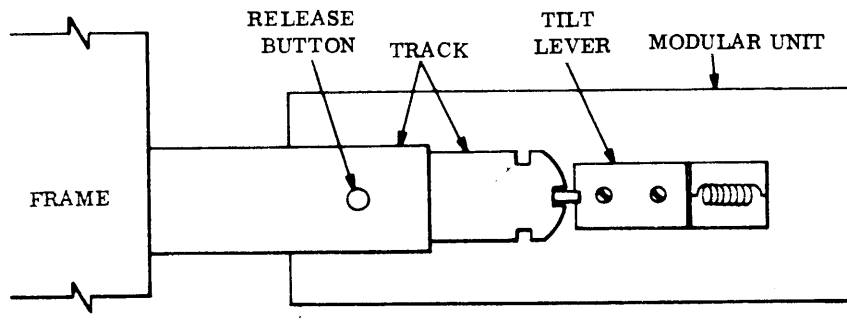

TILTING SLIDE MECHANISM

Figure 2-3. Slide-Mounting Details

CAUTION

With EXTERNAL PRIMARY POWER BREAKER AND MAIN POWER BREAKER SET AT OFF, the single phase ac input should MEASURE NOT LESS THAN 1 MEGOHM TO GROUND. The positive side of the high voltage circuit should measure not less than 100 kilohms.

WARNING

WHEN MEASURING AC VOLTAGE, USE EXTREME CAUTION. DO NOT TOUCH METER OR LEADS WHEN VOLTAGE IS ON. AFTER MEASURING VOLTAGE, PLACE MAIN BREAKER OFF BEFORE REMOVING LEADS.

- a. Insure primary AC BREAKER external to equipment is OFF and TAGGED.
- b. Make sure that the bias potentiometers located in the AP-151 Low Voltage and Bias Supply Drawer are turned to maximum bias (PA BIAS, 2ND AMP BIAS, and 1ST AMP BIAS potentiometers extremely clockwise).
- c. Place an ac voltmeter across the single phase input of the high voltage transformer located in the AP-152, High Voltage Power Supply (T101 terminals 1 and 3). The meter should be on the 300 vac range.
- d. Clear personnel away from the HFLA-1K and apply primary power.
- e. On the AP-152 set the MAIN POWER breaker to the ON position.
- f. On the AP-151 set the PLATE and SCREEN breakers to the ON position.
- g. Wait approximately 10 to 15 minutes for all tube filaments to warm up.
- h. On the AX-5130 unit press the HIGH VOLTAGE pushbutton switch; the HIGH VOLTAGE indicator should light. (H.V. pushbutton may have to be pressed twice)
- i. Note the ac input voltage as measured on the ac voltmeter.
- j. Press th HIGH VOLTAGE switch again to remove high voltage; the HIGH VOLTAGE indicator must go out.
- k. Place MAIN POWER breaker to OFF position.
- l. If the ac voltage noted in step i does not correspond with the ac input terminal markings on the high voltage transformer, relocate the ac input leads to the corresponding terminals on the high voltage transformer (refer to figure 7-2). Insure primary AC BREAKER external to equipment is OFF and TAGGED prior to performing the relocation of ac input leads.
- m. Repeat step l. Referring to figure 7-1 for corresponding voltage taps on low voltage and filament transformer T301 and T302. (located in AP-151 unit)
- n. Press H.V. pushbutton to remove high voltage.

#### 2-4. PRE-OPERATIONAL CHECKOUT PROCEDURE

Once the installation procedures are completed, pre-operational checks outlined in this paragraph should be performed to insure correct installation. Perform the operations outlined in Table 2-1.

TABLE 2-1 PRE-OPERATIONAL CHECKOUT PROCEDURE

<u>Step</u>	<u>Modular Unit</u>	<u>Operation</u>	<u>Normal Indication</u>
1	AX-5130	Loosen panel locks on AX-5130 and slide unit on chassis slides. Set auto/manual switch to MAN.	No Indications
2	AP-152	Set MAIN POWER breaker to ON position.	MAIN POWER indicator should light. Band indicator on TLAA should light.
3	AP-151	Set SCREEN & PLATE breakers to the ON position.	Approximately 60 seconds the interlocks lamp must light. If not, check that all interlock switches are closed.
4		Loosen panel locks on AP-151 and slide unit on chassis slides to expose BIAS ADJUST controls.	

NOTE

The following steps give instructions for setting quiescent current values. Insure that the transmitter PTT line is closed (via associated exciter or jumper on interface panel) before attempting to set amplifier quiescent currents.

CAUTION

Before applying high voltage to the transmitter, insure that the RF GAIN control on the AX-5130 is fully counterclockwise.

5	AX-5130	Press the HIGH VOLTAGE switch to light indicator (it may be necessary to press the HIGH VOLTAGE switch twice).	HIGH VOLTAGE switch indicator will illuminate red.
---	---------	--	--

NOTE

For steps 6,7, and 8 the BIAS controls are located in the AP-151 drawer. Each individual amplifier has a bias level within the specified ranges, but peculiar to itself, in order for the amplifier to operate with minimum distortion.

TABLE 2-1 PRE-OPERATIONAL CHECKOUT PROCEDURE(cont)

<u>Step</u>	<u>Modular Unit</u>	<u>Operation</u>	<u>Normal Indication</u>
6	TLAA-1K	Set the Ip meter switch to 1ST AMP, and adjust the 1ST AMP BIAS control (located in AP-151) for 40 ma on the Ip meter.	Ip meter will indicate quiescent current of 40 ma.
7		Set the Ip meter switch to 2ND AMP, and adjust the 2ND AMP BIAS control (located in AP-151) for 200 ma on the Ip meter.	Ip meter will indicate quiescent current of 200 ma on the Ip meter.
8		Set the Ip meter switch to PA, and adjust the PA BIAS control (located in AP-151 for 200 ma on the Ip meter.	Ip meter will indicate quiescent current of 200 ma.
9	AP-151	Slide AP-151 back into equipment cabinet and lock in place.	
10	TLAA-1K	Rotate BAND control (clock-wise only) observe that BAND indicators light for each band position.	

SECTION 3  
OPERATOR'S SECTION

NOTE

For transmitter operating procedures refer to OPERATOR'S SECTION within the transmitter system manual.



## SECTION 4

### PRINCIPLES OF OPERATION

#### 4-1. GENERAL

The HFLA-1K transmitter provides fully automatic, or manual continuous tuning over a frequency range of 2.0 MHz to 30 MHz. The transmitter requires an rf input of at least 100 mw.

The TLAA-1K (power amplifier) contains two broadband low level rf amplifiers and a final amplifier that provides 1000 watts PEP or average output.

Servo tuning of the transmitter is accomplished by Servo Control Unit, AX5130 and associated control circuitry. The transmitter output level is predetermined by four adjustable power level controls which are selected with front panel mounted power level switch. The PA output is maintained constant at the selected power level by ALDC feedback to the exciter.

#### 4-2. BLOCK DIAGRAM ANALYSIS (Refer to figure 4-1)

Figure 4-1 illustrates basic servo tuning control signals and the path of rf input from the exciter through the amplifier stages, to the output meter circuit and transmitting antenna. The basic servo tuning sequence is as follows:

When an unmodulated rf input of 100 mw from the exciter is applied to motor driven RF GAIN control and 100 mw adjust circuit, the application of high voltage causes a cathode voltage input to RF Gain motor control assembly A210 via tune level relay A207K5. Simultaneously servo amplifiers Z201 and Z202 operate to provide motor control voltages to Tune capacitor motor. Load Control assembly A205 causes the load capacitor motor to rotate placing the load capacitor at minimum capacitance.

The RF Gain motor control assembly A210 has been comparing the cathode voltage with the adjustable Tune level voltage. Tune level adjustment determines the rf drive level that the transmitter will servo tune.

RF drive at the desired level is applied to 1ST broadband linear amplifier V1201. The amplified output of V1201 is coupled to the input of 2ND broadband linear amplifier V1202. Further amplification takes place in V1202; the amplified output of V1202 is fed to the input of power amplifier tube V1301 via PA sense circuit A1007.

With the amplified rf input on the input grid of V1301 the motor driven Tune capacitor will develop rf at the plate of V1301 when approaching resonance. A rectified sample of the output called DC Trigger is routed to servo amplifier Z201 via RF Trigger adjust potentiometer. The RF Trigger potentiometer determines the amount of rf necessary to stop the Tune capacitor motor from searching.

Application of the RF Trigger voltage completes the PA tune capacitor

search mode and initiates the servo mode. The servo amplifier will remain in the servo mode until a dc correction voltage from the PA sense assembly approaches zero.

The PA sense compares the relationship between the grid and plate of V1301 to determine when the plate circuit is properly tuned to resonance. When the DC sense voltage is at zero the servo amplifier completes the servo mode and initiates the operate mode.

Until this time in the tuning sequence the load control assembly A205 has received only a PA cathode input which has kept the load capacitor at minimum capacity. This has kept the transmitter unloaded during PA search to assure that sufficient rf plate trigger is always present.

The presence of sampled rf trigger is routed to load sense adjust potentiometer. The load sense adjust voltage is fed to the load control assembly and determines when loading is correct. When the loading is correct motor control voltages diminishes, stopping the Load capacitor.

When the load capacitor stops the servo and load controls are disabled and the tune level voltage is removed from RF gain motor control and the RF GAIN motor starts to drive up. Drive up will continue until the output meter reaches a predetermined level selected by one of the four power level select potentiometers. At the preset output level the output meter sensing circuit will cause the voltage to be removed from the RF GAIN motor stopping the motor.

The ALDC circuit operates together with the power level select switch to maintain a constant selected output level.

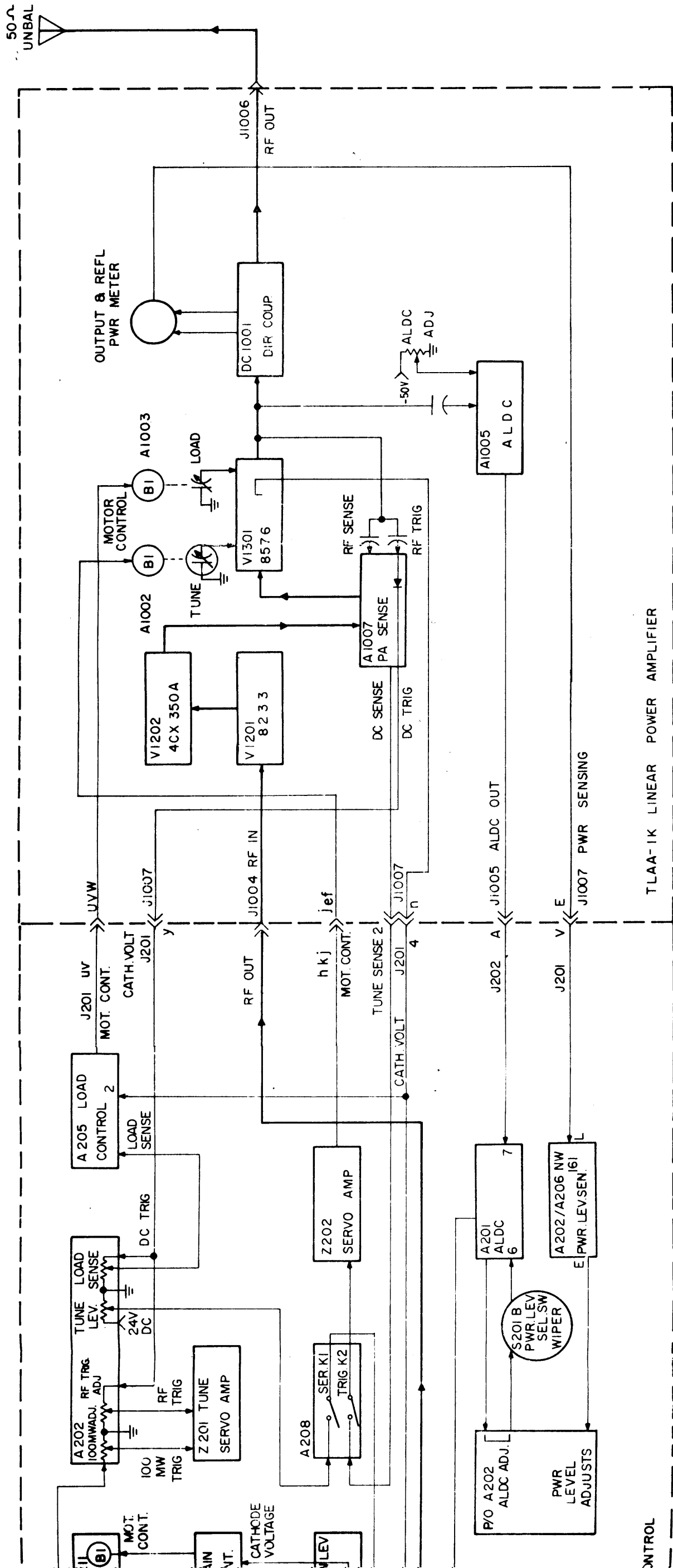

-24V IS FED TO MMX-2B WHEN XMTR  
 THIS VOLTAGE IS USED TO CONTROL  
 LEVEL. MMX RF GAIN CONTROL IS  
 OUT OF THE CIRCUIT.

Figure 4-1. HFLA 1K Functional Block Diagram

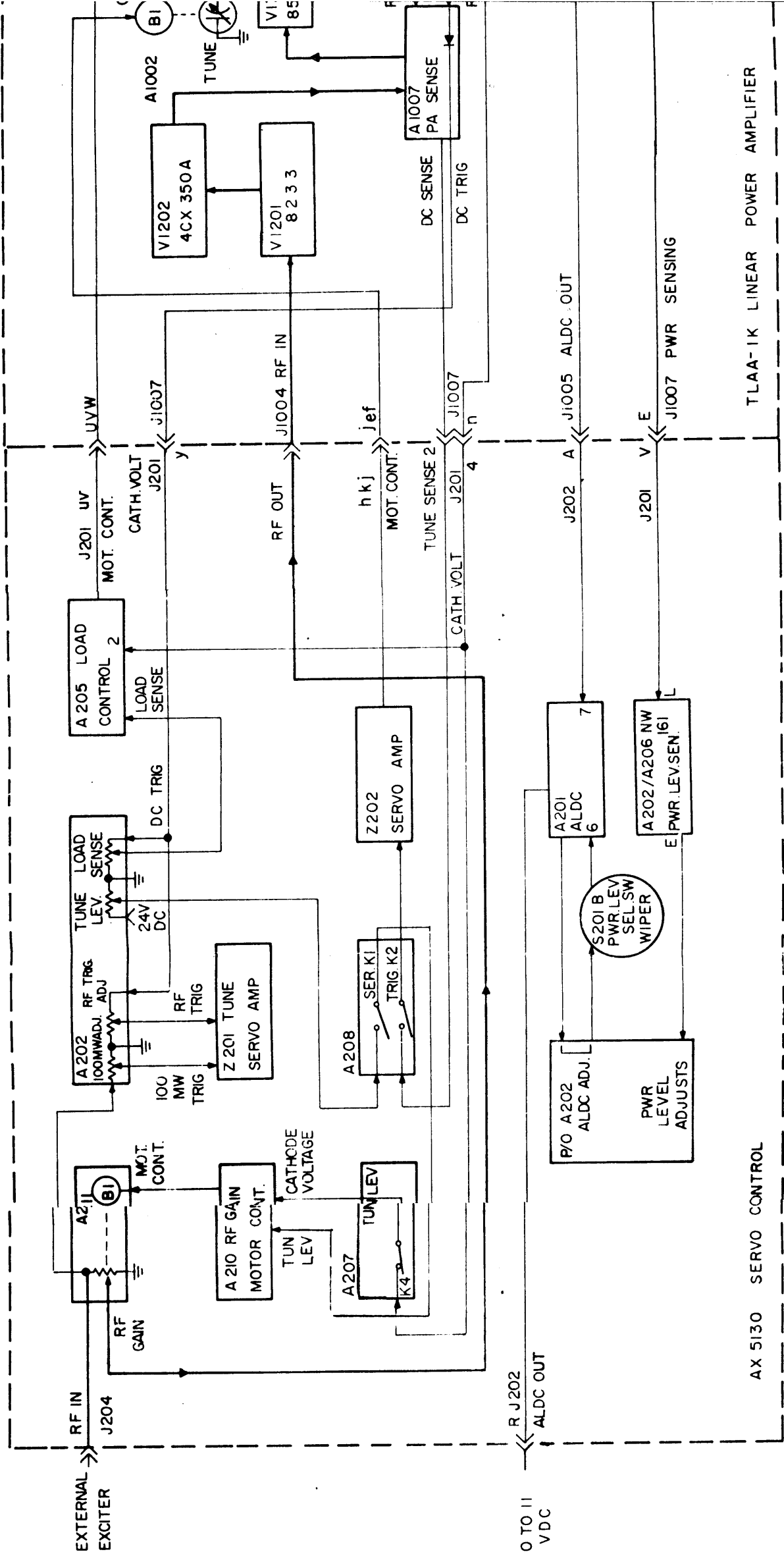

USING MMX-2B 0-24V IS FED TO MMX-2B WHEN XMTR IS ON (AC APPLIED). THIS VOLTAGE IS USED TO CONTROL MMX RF OUTPUT LEVEL. MMX RF GAIN CONTROL IS RELAY SWITCHED OUT OF THE CIRCUIT.

#### 4-3. AC POWER DISTRIBUTION (Refer to figure 4-2)

##### a. General

Single phase primary power is applied to PWR INPUT jack or terminals and provides primary voltages for transmitter operation. The HFLA-1K system is interlocked throughout for personnel and equipment safety. When one of the protective interlocks open, power is removed from the transmitter and high voltage is automatically shut off.

##### b. Block Diagram Analysis

Primary single phase 115 or 230 v vac is connected to PWR INPUT and is routed to one side of MAIN POWER breaker CB101. Closure of the MAIN POWER breaker provides ac power to the MAIN POWER indicator (DC101), high voltage on/off relay contacts (K101), one section of high voltage transformer (T101), front and rear fans B101 and B102 respectively. AC power is also routed through J101 pin I and enters the TLAA-1K at J1003 pin u, to one side of PA fan B1301. Primary ac is applied to the other side of the PA fan via fan fuse F303 causing the fan to operate thus closing the contacts of blower air switch S1301. The closed air switch contacts provides an ac path through J1003 pin v and is routed to Low Voltage and Bias supply at J301 pin h and re-routed to one side of filament/bias transformer T301 and one side high voltage transformer T302.

Single phase ac is also routed through AP-152 J101 pin H to J301 pin E and through Low Voltage fuse F303 to the other side of Low Voltage transformer T302.

##### c. Low Voltage/Bias Power Supply AP151

With primary ac applied to the primary of low voltage transformer T302, 36 vac is applied to 24 dc supply and to the Servo Control unit AX5130 at J201 pins E and F. The secondary of T302 also provides 52 vac to the Servo Control unit at J201 pins D and C. Primary ac at the junction of J301 pin E is also routed to Filament/Bias transformer T301 via filament fuse F302. The secondary of transformer T301 provides 230 vac to K301 bias relay contacts, 6.8 vac for the PA filament voltage, and bias voltage for the amplifier tubes. Primary ac is also applied to the Servo Control unit at J201 pins M and N.

##### d. Servo Control Unit AX5130

The primary power (115 vac) is routed to RF Gain Motor Control Assembly A210 via J201 pins M and N. Assembly A210 controls the operation of RF Gain motor B1. At the junction of J201 pin M primary voltage is also routed to K201 servo off relay contacts set 5 and 6 to J201 pin t, and is re-routed to J1007 pin d in the TLAA-1K. The 52 vac provided by the secondary of T302 appears at J201 pins D and C and is routed to servo-off relay contact set (1) and (4) and assembly A208 tune sequence control, and Z202 servo amplifier.

The 36 vac provided by the secondary of transformer T302 appears at J201 pins E and F and is routed to Load Control assembly A202.

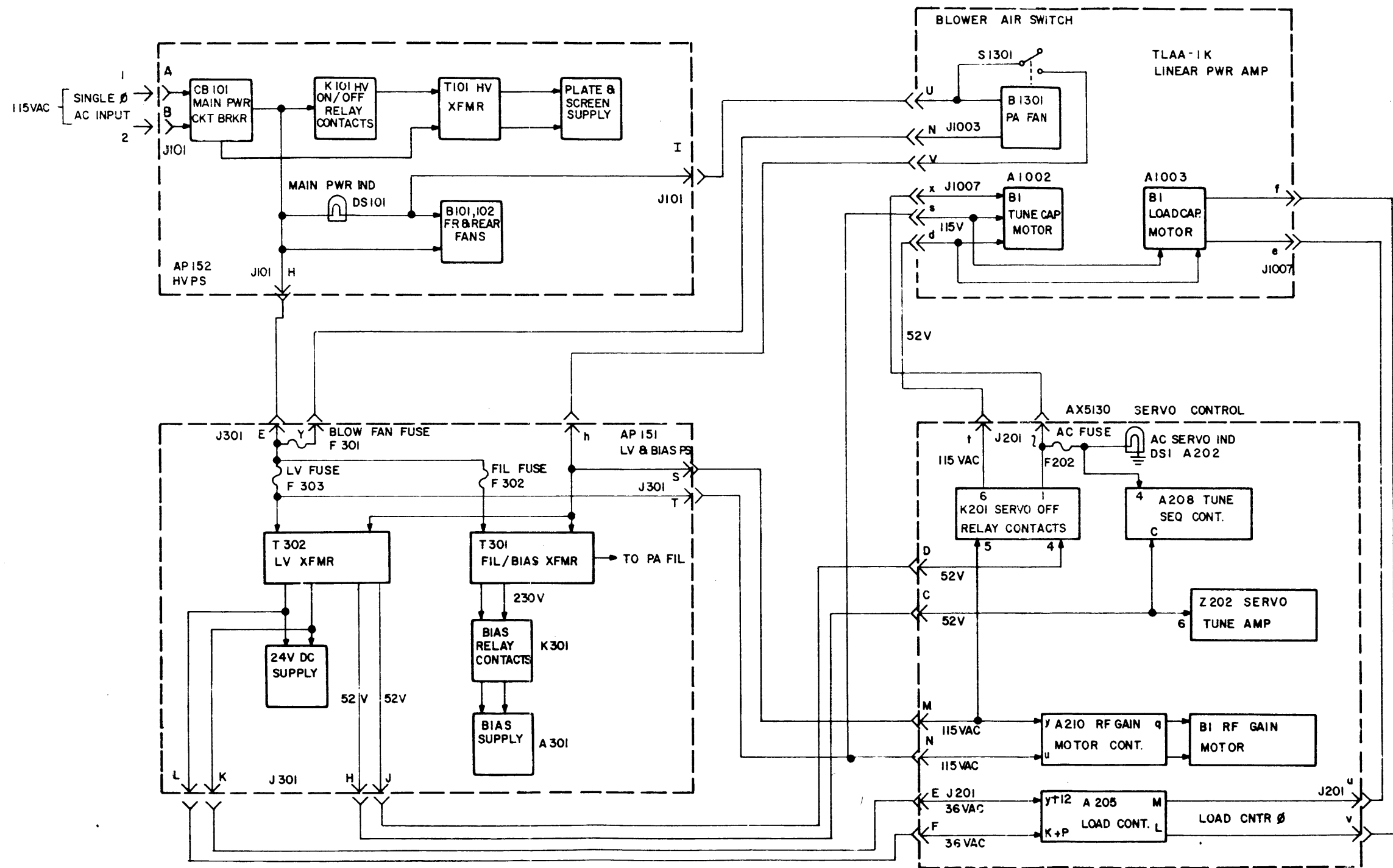

004711051

Figure 4-2. AC Power Distribution

Load Control assembly A202 provides the load control phase to the load capacitor motor assembly A1003.

e. Linear Power Amplifier TLAA-1K

Primary ac is routed to the Tune capacitor motor A1002 B1 and load capacitor motor A1003 B1 via AP-151 (J301 pin T) and K201 servo off relay contact set 5 and 6. At J1007 pin x 52 vac is also routed to A1002 B1 for motor control.

It can be seen thus far that should PA fan B1301 fail to operate ac power would be removed from both the filament bias transformer, T301 and low voltage transformer T302. When voltage is removed from T301 and T302, primary bias voltage, filament voltage and the 24 vdc would be disabled.

4-4. DC POWER DISTRIBUTION (Refer to figure 4-3)

a. Plate and Screen Voltages

Application of ac power to High Voltage transformer T101 provides plate and screen voltage for RF Amplifier tubes V1301, V1201, and V1202. 4000 vdc is derived from plate rectifier A101 for plate voltage to the PA tube V1301.

Screen rectifier A102, also rectifies the secondary output of T101. This rectified output is fed to Zener diode assembly A103 that functions to regulate dc voltage potentials. Within the zener assembly, voltages are tapped and applied to RF Amplifier tubes as follows:

- (1) 200 vdc First Amplifier Screen (V1201)
- (2) 400 vdc Second Amplifier Screen (V1202)
- (3) 600 vdc Power Amplifier Screen (V1301)

The screen rectifier also furnishes 2000 vdc for the plate of V1202 and 400 vdc for the plate of V1201.

Filament transformer T301 supplies 6.3 vac filament voltage to each RF Amplifier tube.

b. BIAS Voltage (Refer to figure 4-4)

When Bias Relay K301 energizes, ac voltage is applied to the bias rectifier A301. The negative dc output of A301 (approximately 240 vdc) is filtered by L301 L302, C301 and C302 before application to the zener diode regulators. The dc return for the Bias supply is through Bias fuse F304 to protect the circuit against overloads. Regulated bias voltages are tapped from Zeners CR301 and CR302 for application to the three bias potentiometers. The ground necessary for the voltage drop across the PA bias potentiometer is supplied by contacts of the energized PTT relay K1. The bandswitch and/or harmonic filter interlock circuit prevents 24 vdc from reaching the PTT relay during band changes to keep the PA amplifier stage at maximum bias, or close to cut off.

The bias supply provides -200 vdc to the PA bias potentiometer. The bias potentiometer is adjusted to provide 200 ma quiescent current on the PA (Ip) plate current meter when the meter switch

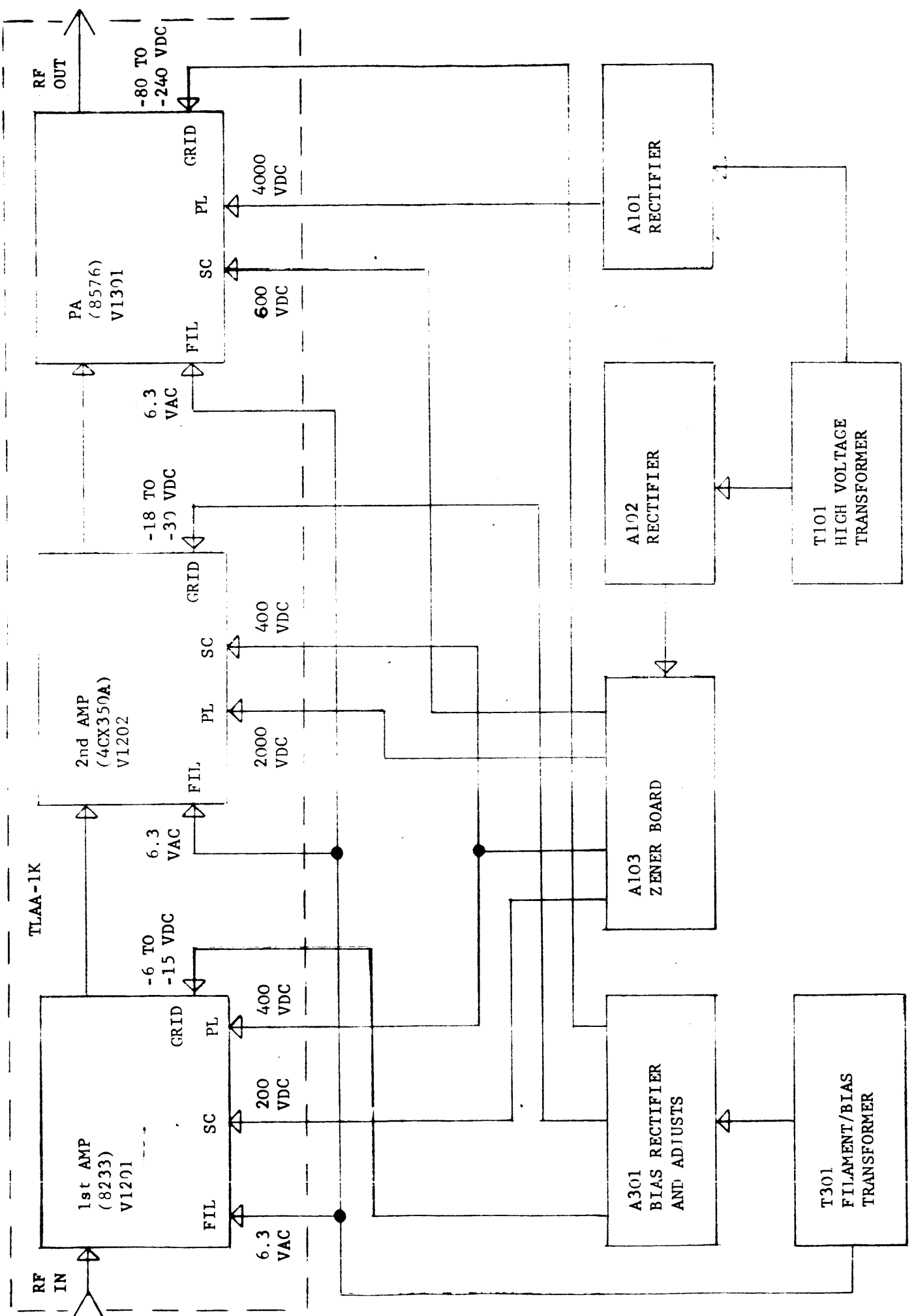

FIGURE 4-3. HFLA-1K OPERATING POTENTIALS





is in its normal position. The junction of CR301 and CR302 provides -50 vdc to the 2ND AMP and 1ST AMP bias potentiometers before application to the 2ND and 1ST AMP grids. The 2ND AMP bias potentiometer is adjusted to provide 200 ma on the Ip meter when the meter switch is in the 2nd AMP (up) position. The 1st AMP bias potentiometer is adjusted to provide 40 ma when the meter switch is in 1st AMP (down) position.

#### 4-5. PROTECTIVE INTERLOCKS AND OVERLOADS

Simplified High Voltage Overloads and Interlocks Circuit Analysis  
(Refer to figure 4-6)

The 24 vdc derived in the AP-151, Low Voltage and Bias supply is routed to Time Delay Z1101. When the elapsed time is completed the 24 vdc is routed through mechanically closed protective interlocks (S1101, S1003, S2001, S2003 and External interlock). When all interlocks are closed 24 vdc is applied to K301 the bias on relay and Interlock indicator DS301, CB302 PLATE circuit breaker, CB301 SCREEN circuit breaker and one side of H.V. on/off relay K101. At the junction of SCREEN circuit breaker CB301 and H.V. on/off relay K101 24 vdc is re-routed through one section of H.V. on switch S203 to one side of RESET relay A301K2.

When H.V. on/off switch is pressed to ON (switch indicator lights) 24 vdc is switched to overload board A1001, H.V. ON indicator DS203, H.V. ON indicator DS302, consequently lighting both H.V. indicators. Simultaneously a ground path is provided via contacts on reset relay K2 and this ground is routed to H.V. ON/OFF relay K101, and H.V. ON indicators. Closed contacts on K101 energizes the plate and screen supply providing plate voltage and screen voltage to the RF amplifier tubes V1201, V1202, and V1301.

When an interlock switch is opened the 24 vdc is removed from H.V. ON/OFF relay K101 and Bias relay K301 and is re-routed via the normally closed position of the interlock switches to the overload relay A301K1. The energized overload relay removes the ground that is required to energize the H.V. ON/OFF relay and H.V. ON indicator lights.

The contacts on the overload relay also provide a ground path to one side of ALARM ON/OFF switch S301 (when ALARM switch is in ON position with H.V. off due to an overload the audible alarm would sound).

An indication on the PLATE current meter (Ip) that is equal to the setting of the red overload pointer provides a contact closure on the meter sensing circuit. The contact closure supplies a gating pulse to trigger an overload SCR, providing a path for the 24 vdc to the overload lamp on the meter, and 24 vdc to the OVL D relay, causing it to unlatch and de-energize the H.V. ON/OFF relay.

A dc sample from the reflected power diode is routed through an operational amplifier and the SWR ADJ. potentiometer. The dc sample provides a trigger for the associated SCR, providing a path for the 24 vdc to the SWR overload lamp on the RF Amplifier front panel.

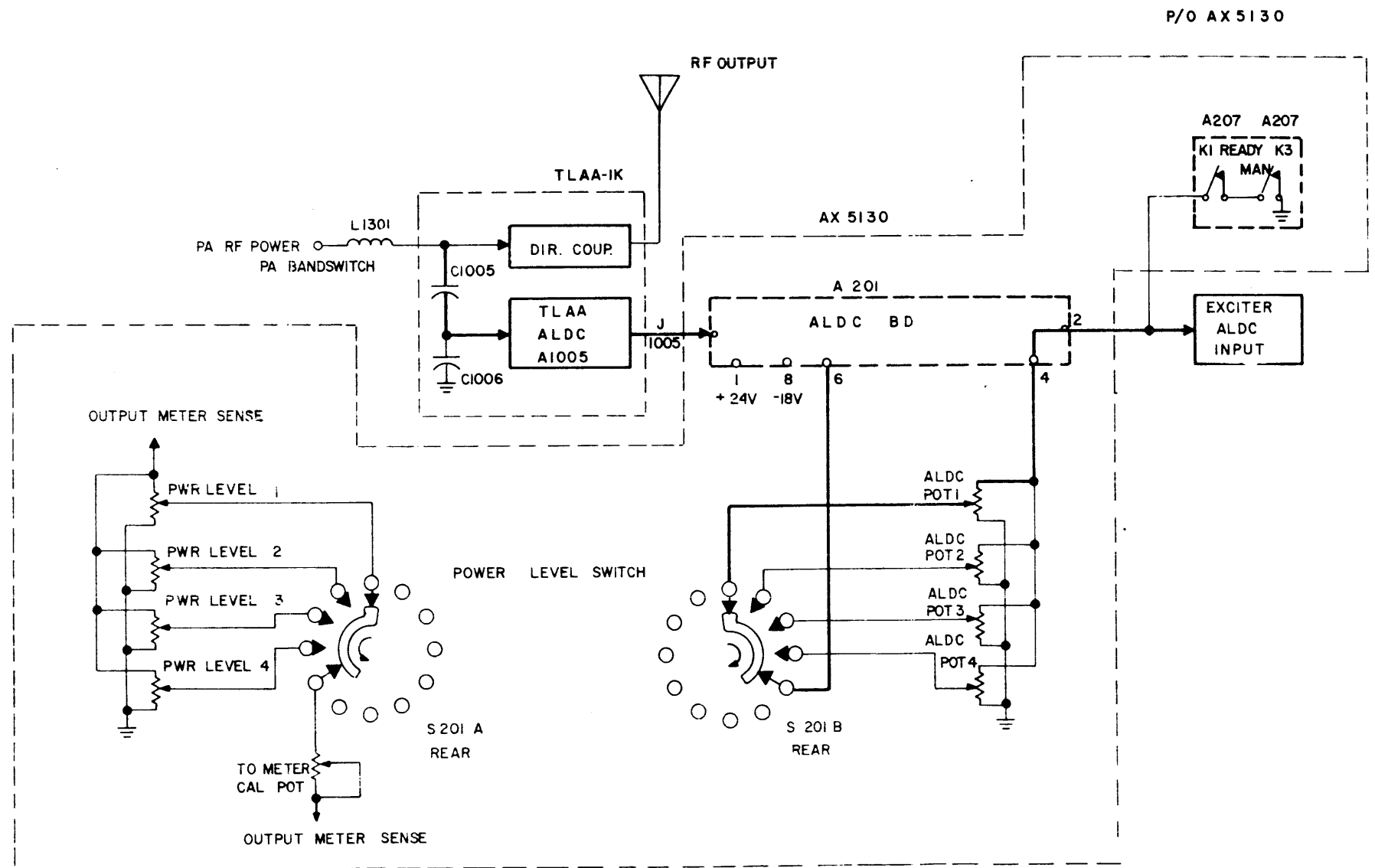

004711051

Figure 4-5. Simplified ALDC Circuit

To restore high voltage, the H.V. ON/OFF pushbutton switch is pressed twice. Pressed the first time, the H.V. ON/OFF switch provides 24 vdc to the reset side of the OVLDR RELAY and closing the contacts on the relay. Pressed the second time, the H.V. ON/OFF switch restores the 24 vdc to the contacts necessary to energize the H.V. ON/OFF relay which applies plate and screen voltages to the transmitter again.

Should any of the interlocks open when H.V. is ON, the overload coil on the overload relay is diverted to a line connecting all the normally closed contacts of the interlocks to the overload side of the overload relay. An open interlock places the transmitter in an overload condition, preventing the potentially dangerous application of high voltage when the open interlock is closed.

#### 4-6. ALDC (Refer to figure 4-5)

The Automatic Load and Drive Control (ALDC) circuit provides a feedback voltage to the associated exciter to prevent excessive rf output from the transmitter. Selection of Power Levels 1, 2, 3 or 4 will select the corresponding ALDC potentiometer for that particular Power Level selection.

Power Level switch S201A and S201B selects the appropriate ALDC potentiometer and Power Level potentiometer. The transmitter RF output is sampled through C1005 and fed to ALDC circuit A1005 in the TLAA-1K. This sampled rf voltage is rectified and filtered in A1005 and routed to servo control unit AX5130. Within the TLAA's ALDC circuit is the front panel ALDC adjust potentiometer, which determines the magnitude of the ALDC voltage fed to the servo control unit.

This adjustable ALDC voltage is routed through ALDC jack J1005 to AX5130's ALDC board input. AX5130's ALDC circuit (A201) consist of two operational amplifiers connected to provide a negative feedback voltage to the exciter's ALDC input jack. The voltage derived in A201 is routed to Power Select switch S201B wiper arm. With S201 in position 1 as shown in figure 4-5 the switch contact is connected to ALDC potentiometer 1 which will determine the operational amplifier's output level. This preadjusted ALDC voltage is routed to the exciter's ALDC input jack.

ALDC adjust potentiometer 1 is adjusted after the transmitter has completed the auto tune cycle and READY relay K1 has latched into the READY position.

During the auto tuning process the ALDC voltage is shorted to ground through contacts on the READY relay. Once auto tuning is completed the READY relay energizes lighting READY indicator and removes the ground on the ALDC line.

#### 4-7. AUTOMATED TUNING SEQUENCE (Refer to figure 7-4)

##### a. Initial Requirements for Automatic Tuning

The initial requirements to commence the automated tuning sequence are: AUTO/MANUAL switch placed in AUTO position, an rf carrier input of 100 mw from an exciter and the application of high voltage with the H.V. ON/OFF

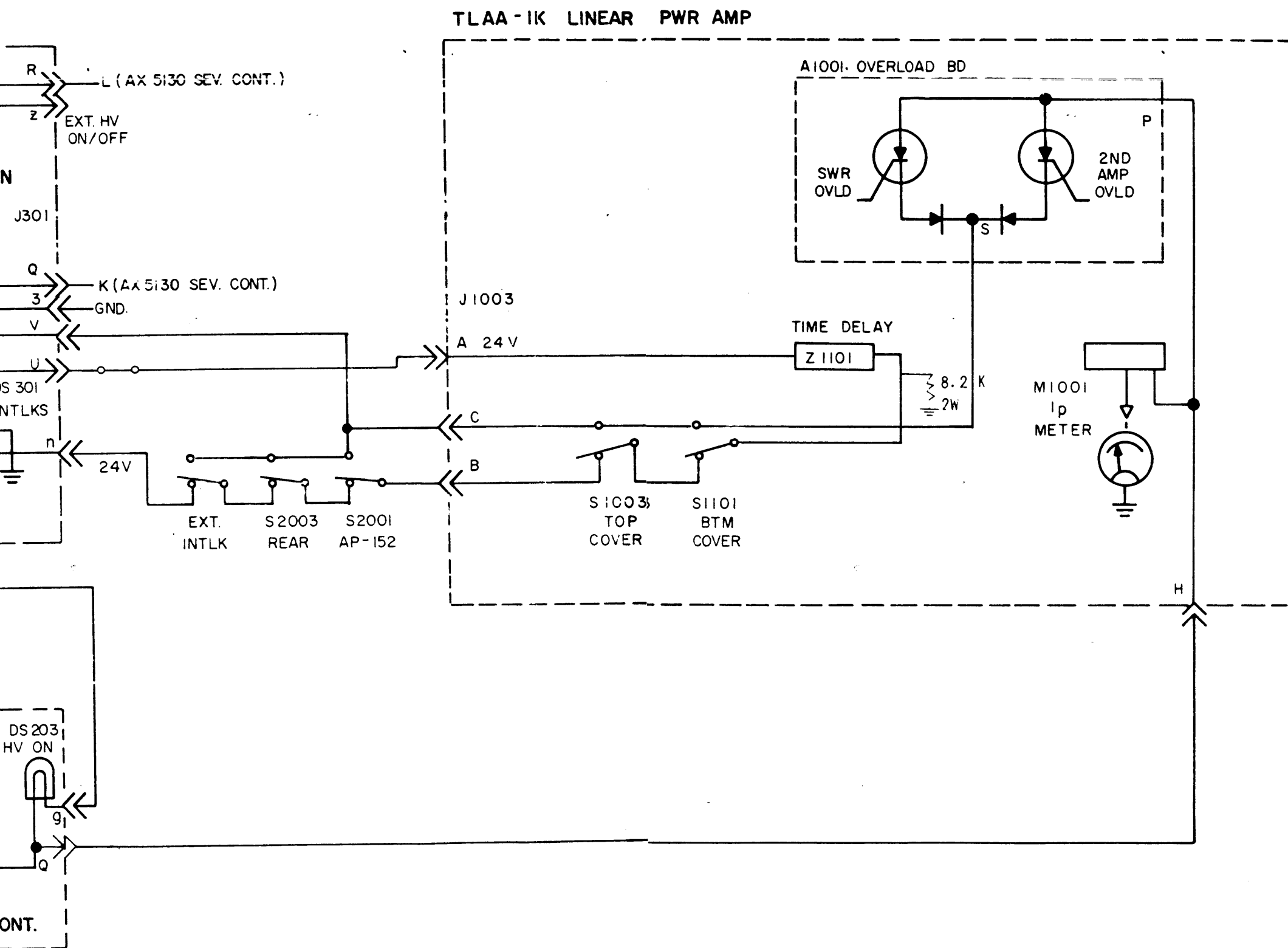

004711051

Figure 4-6. Simplified Interlock & HV Overload Circuits

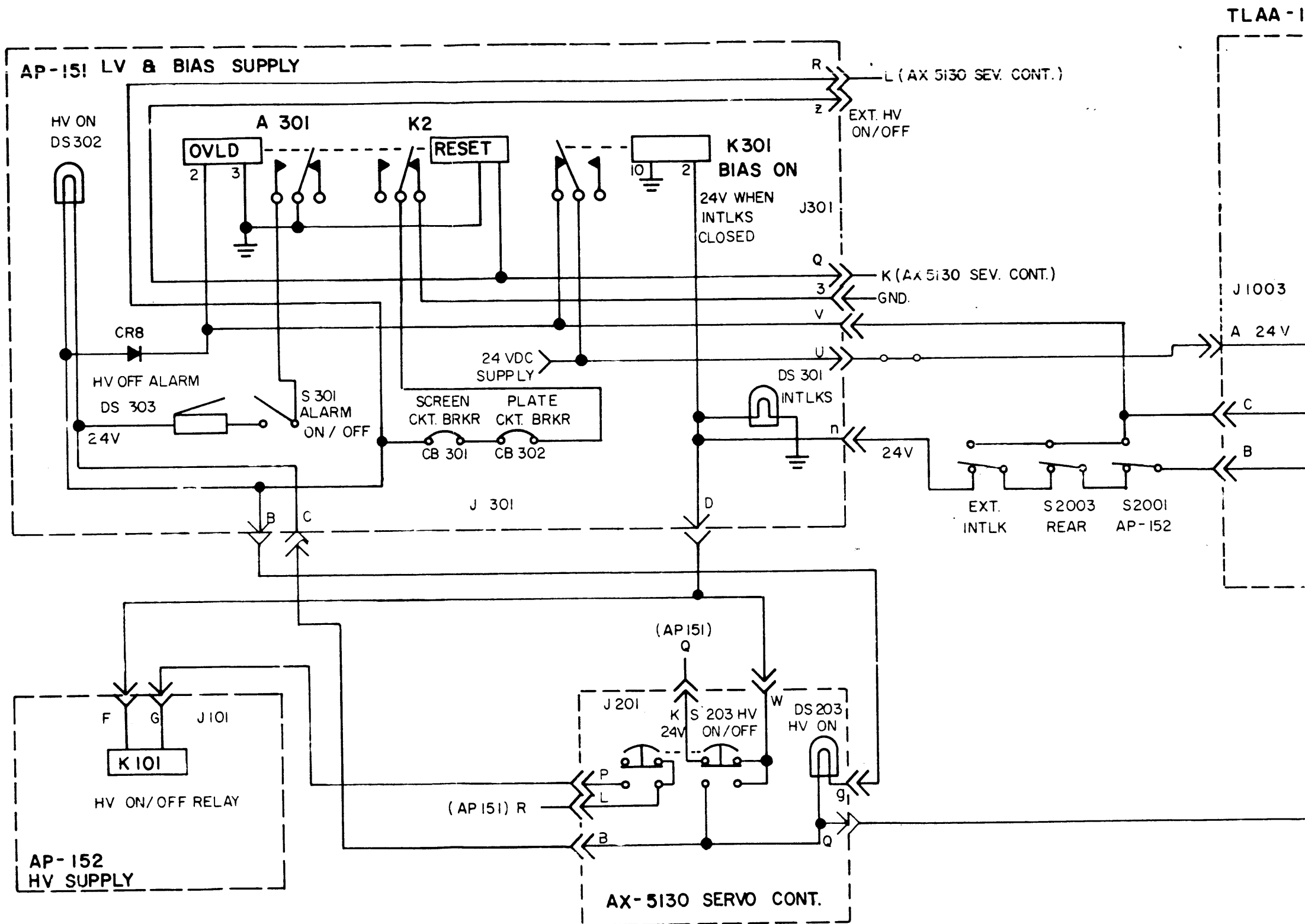

switch. Pressing the TUNE pushbutton starts the tuning sequence by providing a ground to pin (6) of connector AX209, pins (7) and (16) of connector AX207. The ground seen at AX207 and AX209 places the following relays in the tune condition:

- (1) Servo Recycle, A209K3
- (2) Servo Off, K201
- (3) Load Recycle, A209K4
- (4) RF Gain Recycle, A207K4
- (5) Tuning Level, A207K5
- (6) Servo Complete, A207K2
- (7) Ready, A207K1

The application of high voltage provides approximately 260 ma of quiescent current in the Power Amplifier tube, V1301. The voltage derived from the PA cathode is routed through J201 pin (4) to pin (2) of Load Control assembly A205, through the closed contacts (14) and (15) of Tune Level relay A207K5, to pin (2) of RF Gain Motor Control assembly, A210.

b. 100 MW Trigger (Used only when HFLA-1K is not part of a TMC transmitting system)

The 100 MW rf input at J204 is applied to the motorized RF Gain control A210R1 and the 100 MW rectifier A202CR1. The positive voltage output from the rectifier is applied to pin (1) of servo amplifier Z201 through 100 MW Trigger control A202R6. Application of 100 MW trigger at pin (1) of Z201 causes Search relay A208K1 to energize. The now closed contacts (7) and (6) of A208K1 cause the SEARCH lamp to light indicating PA TUNE capacitor rotation. The voltage that is applied to SEARCH lamp simultaneously is applied to Servo Rotation relay A208K4 and PA TUNE capacitor rotates searching for resonance.

c. Tune Level

24 vdc is routed to pin (7) of AX202, regulated to 12 vdc by zener diode A202CR and applied to the Tune Level control. The Tune Level control adjusts this voltage called Tune Level voltage. Then routes it out pin (L) of A202 through closed contacts (9) and (8) of Tuning Level relay to pin (21) of RF Gain Motor Control assembly A210.

There are 2 inputs appearing at Motor Control assembly A210, a sample of PA cathode voltage on pin (2) and a Tune Level voltage on pin (21). If the cathode voltage on pin (2) is less than the Tune Level voltage on pin (21), Q1 will be forward biased causing relay A210K1 to energize. If the voltage on pin (2) was greater than the voltage on pin (21), Q2 would be forward biased causing relay A210K2 to energize.

Relay A210K1 causes the RF Gain motor to rotate in a clockwise direction, the RF Gain potentiometer shaft is connected to the RF Gain motor therefore the RF Gain control rotates clockwise and increases the rf drive to the input grid. As the drive increases the PA cathode voltage also increases. The RF Gain motor will drive up until the cathode voltage on pin (2) of assembly A210 is equal to the preadjusted Tune Level voltage on pin (21). When the cathode voltage and Tune Level voltage are equal the conduction of Q1 decreases releasing relay K1 from its energized state thus removing the drive up voltage from the RF Gain motor.

The Tune Level potentiometer is adjusted to a point that when the PA cathode current is at 220 ma the Tune Level voltage on pin (21) and the cathode voltage on pin (2) are within .7 vdc of each other. If for example the cathode voltage is not present on pin (2) of A210, the RF Gain motor will continue to drive up until the upper limit switch S3 is actuated removing the motor voltage. If the Tune Level voltage is not present K2 will energize causing the RF Gain motor to drive down until the actuating arm on the opposite side of the RF Gain control shaft opens the lower limit switch removing the drive down voltage to the motor.

#### d. PA Tune Search

When High Voltage is ON and rf input is applied to the TLAA's RF IN jack, J1004, the resultant amplified rf output of V1201 and V1202 is fed to PA input grid via PA Sense assembly A1007. The plate of V1301 is also connected to PA Sense assembly A1007.

Whenever the AUTO/MANUAL switch is placed in the AUTO position a fixed voltage is present on the PA Tune motor windings. Control voltage to the control winding of the PA Tune motor is supplied by pins (8) (5) and (15) of servo amplifier Z202. The PA Tune motor will start rotating (searching) in the direction that A208K4 had last latched in, if A208K4 had latched and contacts (6) (7) close the PA Tune motor would start searching in a clockwise direction until it hits the PA Tune microswitch or it finds an rf trigger to stop it. Should the PA Tune control rotate in clockwise direction and hit the PA Tune micro switch closure of the micro switch will cause the motor direction to be reversed.

As resonance is approached a sample of the PA plate rf leaves the PA sense assembly and is routed through jack J1007 pin (j) for application to RF Trigger potentiometer, A202R8. The RF Trigger adjustment determines the required level of Plate rf necessary to stop the PA Tune capacitor from searching. The DC trigger voltage leaves the PA Sense amplifier Z201 via the RF Trigger adjustment potentiometer A202R8.

With the application of DC Trigger the Search mode ends and the Servo mode commences, with motor control being switched from a fixed voltage within the servo amplifier to a dc correction voltage from the PA Sense assembly. The servo amplifier will remain in the Servo mode until the DC sense voltage from the PA sense assembly diminishes to zero at which time the OPERATE lamp will light indicating completion of tuning.

The DC Sense voltage leaves the PA Sense assembly a J1007 pin (L) and enters the servo amplifier via closed contacts of trigger relay A208K2. The DC sense voltage on Z202 provides the necessary change in control voltage to bring the PA Tune motor to resonance.

#### e. PA Load Operation

During the tuning sequence thus far the PA Load capacitor is at the minimum loading position to insure that sufficient plate rf is always present. Once the PA Tune capacitor is brought to resonance by the dc correction voltage, and this correction voltage diminishes at the point of PA resonance the PA Load operation is as follows:



The diminishing dc correction voltage causes Operate relay A208K3 to de-energize providing a closure between pins (6) and (7) which causes Operate lamp DS3 to light. The ground seen at pin (10) of K3 is also removed when Operate relay K3 is de-energized. Pin (10) of K3 is connected to Pin (14) of Load control assembly A205. Load control assembly is a level sensing circuit consisting of three transistors, (Q1, Q2 and Q3) and two control relays (K1 Load maximum and K2 Load minimum). Load control assembly A205 receives a sample of plate rf voltage on pin (21), a sample of PA cathode voltage on pin (2), 24 vdc via Servo complete relay on pin (3) and a ground provided by the operate relay A208K3 when energized.

The de-energized Operate relay removes the ground applied to the base of switching transistor Q2 allowing Q2 to conduct and providing 24 vdc to Load maximum relay K1. A sample of PA cathode voltage present at the base of Q3 together with plate RF causes transistor Q3 to conduct when the rf is greater than the cathode voltage, the conduction of Q3 turns on transistor Q1 which supplies the ground required to energize Load maximum relay K1.

The energized K1 contacts provide control voltage to the load motor and causes the Load capacitor to rotate towards maximum loading. As the PA Loading increases, the plate rf voltage present on pin (21) of A208 and applied to the emitter of transistor Q3 is compared to the PA cathode voltage which is applied to the base of Q3. Transistor Q3 senses the base and emitter levels and when they are within .7 vdc the conduction of Q3 decreases. As transistor Q3 decreases conduction, the base voltage decreases on transistor Q1 and Q1 ceases to conduct thereby causing Load maximum relay K1 to de-energize. The de-energized K1 removes the applied voltage to PA Load motor and supplies 24 vdc through pins (D) (T) (W) to energize Servo Complete relay A207K2.

The Load Sense potentiometer, A202R5 is adjusted so that loading is correct when the voltage present on TP-1 and TP-2 are within .7 vdc of each other.

Assume that the PA cathode voltage was not present, transistor Q3 and Q1 would conduct energizing relay K1 and PA loading would increase to maximum until it actuated the load max micro switch, which would remove the motor voltage.

#### f. Fault

The adjustable fault circuit provides an energizing ground to the Servo off relay which removes voltage to the servo amp and biases the transmitter at or near cutoff should the transmitter fail to tune within approximately 30 seconds.

The RC time constant of R4, the Delay Adjust and C1 in assembly A209 determine the delay desired to energize Fault relay K2. When K2 is energized the ground provided by contacts (6) and (7) energize the Servo OFF relay removing AC power to the servo amplifier shutting them off. Normally closed contacts (5) and (6) open removing the energizing ground from the PTT relay coil. De-energized PTT relay will cause Power amplifier stage to receive maximum bias voltage thus placing the PA at or near cutoff.

To recycle the tuning sequence after a fault has been obtained requires depression of the TUNE button. Pressing the TUNE button momentarily energizes the SERVO RECYCLE relay and removes the 24 vdc applied the FAULT relay coil. With the 24 vdc removed the FAULT indicator goes out and the tuning sequence starts again.

SECTION 5  
MAINTENANCE

5-1. INTRODUCTION

The HFLA-1K has been designed for long term trouble free operation. When it becomes necessary to perform alignment and/or adjustments to the equipment, it is recommended that technicians perform the necessary operations outlined in the applicable paragraphs in this section.

A. The following maintenance aids are provided for troubleshooting, alignment and replacement of parts.

1. System block diagram (Section 4 Figure 4-1)
2. Fuse Location Drawing (Figure 5-1)
3. Fuse Functions (Table 5-2)
4. System overload and bias setting procedure
5. Auto-Tuning adjustment procedure

5-2. LIST OF TEST EQUIPMENT REQUIRED

Signal Generator	Hewlett Packard Model 606A or equivalent
VTVM	Hewlett Packard Model 410B or equivalent
Multimeter	Simpson Model 260 or equivalent

5-3. OPERATOR'S MAINTENANCE PROCEDURE

a. Refer to operational checkout procedures for manual or automatic depending on desired mode of operation (Paragraph 3-4).

b. Refer to operator's troubleshooting chart (Table 5-1).

5-4. PREVENTIVE MAINTENANCE

In order to prevent equipment failure due to dust, dirt or other destructive elements, it is suggested that a schedule of preventive maintenance be set up and adhered to.

At periodic intervals, the equipment should be pulled out on its slides for internal cleaning and inspection. The wiring and all components should be inspected for dirt, dust, corrosion, grease or other harmful conditions. Remove dust with a soft brush or vacuum cleaner. Remove dirt or grease with any suitable cleaning solvent. Use of carbon tetrachloride should be avoided due to its highly toxic effects. Trichlorethylene or methyl chloroform may be used, providing the necessary precautions are observed.

### WARNING

WHEN USING TOXIC SOLVENTS, MAKE CERTAIN THAT ADEQUATE VENTILATION EXISTS. AVOID PROLONGED OR REPEATED BREATHING OF THE VAPOR. AVOID PROLONGED OR REPEATED CONTACT WITH SKIN. FLAMMABLE SOLVENTS SHALL NOT BE USED ON ENERGIZED EQUIPMENT OR NEAR ANY EQUIPMENT FROM WHICH A SPARK MAY BE RECEIVED. SMOKING, "HOT WORK", ETC. IS PROHIBITED IN THE IMMEDIATE AREA.

### CAUTION

WHEN USING TRICHLORETHYLENE, AVOID CONTACT WITH PAINTED SURFACES, DUE TO ITS PAINT REMOVING EFFECTS.

## 5-5. TROUBLESHOOTING

The first step in troubleshooting the automated system is as follows:

### a. Observations

Observe the operation of transmitter and determine whether the indications are normal or abnormal. (Refer to operator's section both manual and automatic tuning.)

### b. Fuse Checks

Should a malfunction occur a visual check of fuses on the system must be performed. (All fuses are indicating type. Refer to Figure 5-1 for fuse location.)

### c. Voltage Checks

At this time voltage checks are not necessary until localization of the malfunction has taken place.

### d. Localization of Malfunction

Perform the operation procedure outlined in paragraph 3-4. Use of this procedure will help localize the particular fault at hand.

### e. Field Maintenance

Procedures presented on the following pages give instructions for qualified personnel to maintain, align, and/or troubleshoot the HFLA-1K Transmitter.

WARNING

WHEN IT BECOMES NECESSARY TO MEASURE TRANSMITTER VOLTAGES, USE EXTREME CAUTION, HAZARDOUS VOLTAGE POTENTIALS ARE PRESENT ALTHOUGH MAIN POWER BREAKER MAY BE OFF. IT IS RECOMMENDED THAT THE FOLLOWING PRECAUTION BE STRICTLY ADHERED TO! !

1. CHECK TO ASCERTAIN MAIN PRIMARY POWER IS OFF OR REMOVED FROM TRANSMITTER.
2. SHORT OUT ALL H.V. POINTS WITH SHORTING STICK.
3. ATTACH TEST METER TO POINT OF TEST DESIRED, RE-APPLY VOLTAGE TO TRANSMITTER.
4. WHEN MEASURING HIGH VOLTAGE POTENTIALS DO NOT TOUCH TEST METER OR LEADS ONCE VOLTAGE HAS BEEN APPLIED.
5. ESTABLISH TEST CONDITIONS AND OBSERVE READING ON TEST METER.
6. REMOVE PRIMARY POWER, SHORT OUT ALL HIGH VOLTAGE POINTS; REMOVE TEST METER.

TABLE 5-1. OPERATOR'S TROUBLESHOOTING CHART

<u>No.</u>	<u>Malfunction</u>	<u>Probable Cause of Malfunction</u>
1	Blower will not operate.	Replace defective BLOWER fuse.
2	PA Plate current and 2ND AMP Plate current excessive.	Replace defective BIAS fuse, or check bias adjustments for proper levels.
3	Interlock Indicator will not light.	Replace defective DC fuse, or check for open interlock.
4	HIGH VOLTAGE indicator will not light when HIGH VOLTAGE switch is pressed.	Replace defective LOW VOLTAGE fuse. Check that PLATE and SCREEN breakers are in ON position. High Voltage switch may have to be pressed twice.
5	Servo indicator on AX5130 will not light in automatic operation.	Check AC and/or DC fuse located on AX5130 chassis. Refer to operating procedure and check that all controls and switches are in the correct position for automatic operation.

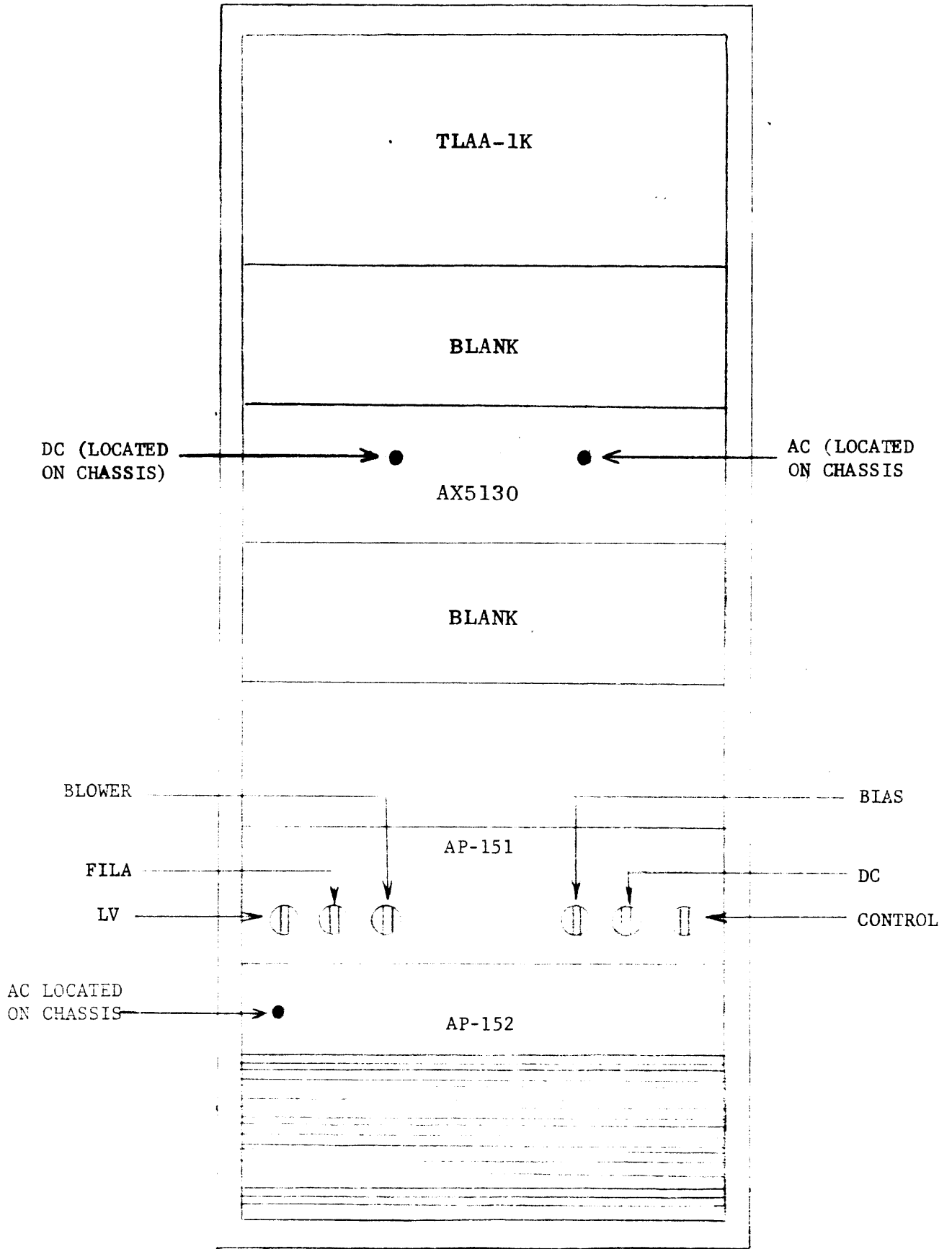

Figure 5-1. Fuse Location

TABLE 5-2. FUSE FUNCTIONS

<u>No.</u>	<u>Fuse</u>	<u>Function</u>
1	BLOWER Fuse	Protective fuse for blower, lights to indicate fuse defective (1.5 amp 115 vac, .75 amp 230 vac).
2	FILAMENT Fuse	Protective fuse for Filament and Bias transformer, lights to indicate fuse defective (2.0 amp 115 vac, 1.0 amp 230 vac).
3	BIAS Fuse	Protective fuse for dc return of bias supply, lights to indicate fuse defective (.2 amp).
4	L.V. Fuse	Protective fuse for primary ac input to L.V. transformer, lights to indicate fuse defective (1.0 amp 115 vac, .5 amp 230 vac).
5	DC Fuse	Protective fuse for dc return of 24 vdc supply, lights to indicate fuse defective (2.0 amp).
6	CONTROL Fuse	Protective fuse for Low Voltage and Filament-Bias transformer, lights to indicate fuse defective (1.0 amp 115 vac).
7	AC Fuse	Protective fuse for servo amplifier, lights to indicate fuse defective. (.5 amp)
8	DC Fuse	Protective for 24 vdc line, lights to indicate fuse defective. (.5 amp)

5-6. ALDC ADJUSTMENT PROCEDURE (Refer to figure 5-2 for control location)

Purpose:

The ALDC adjustments outlined are for the purpose of limiting RF PEAK power during modulation emission modes. The transmitter provides a negative dc voltage which is adjustable and proportional to the transmitter output. This voltage is made available at the transmitter ALDC jack to interface with an appropriate exciter. The exciter accepts this voltage to limit the RF drive.

- a. Extend the Servo Control drawer out on its chassis slides to expose the four ALDC adjustment potentiometers.
- b. Set the MANUAL/AUTO switch to MANUAL, POWER level switch to position 4.
- c. Rotate the front panel ALDC control (on TLAA-1K) counterclockwise for minimum ALDC action. Tune and load transmitter manually, to a carrier frequency of 12 MHz ( a 12 MHz input signal must be available from the associated exciter or a signal generator).
- d. Adjust RF GAIN control for a PA output indication of 1000 watts. Adjust front panel ALDC ADJ clockwise until output meter indicates 500 watts. Adjust ALDC ADJ #4 clockwise until there is no further increase indication on OUTPUT meter. re-adjust front panel ALDC (on TLAA-1K) counterclockwise for minimum ALDC action.

- e. Adjust RF GAIN control for a PA output indication of 1100 watts and adjust front panel ALDC control until ALDC holds PA output at 1000 watts.
- f. Increase RF GAIN (to check ALDC capture) PA OUTPUT should remain constant.
- g. Reduce RF drive minimum, set POWER LEVEL switch to position number 3 and increase RF drive for an indication of 900 watts on OUTPUT meter.
- h. Adjust ALDC ADJ number 3 until PA OUTPUT commences to decrease.
- i. Continue to adjust ALDC ADJ number 3 for a PA OUTPUT indication of 850 watts.
- j. Reduce RF drive to minimum, set POWER LEVEL switch to position number 2.
- k. Adjust RF GAIN for a PA OUTPUT indication of 600 watts. Adjust ALDC ADJ number 2 until POWER OUTPUT commences to decrease.
- l. Continue to adjust ALDC ADJ number 2 for a PA OUTPUT indication of 400 watts.
- m. Increase RF drive (to check ALDC capture). PA OUTPUT should remain constant.
- n. Reduce RF drive to minimum, set POWER LEVEL switch to position number 1 and adjust RF GAIN control for a PA OUTPUT indication of 350 watts.
- o. Adjust ALDC ADJ number 1 potentiometer until PA OUTPUT commences to decrease.
- p. Continue to adjust ALDC ADJ number 1 for a PA OUTPUT indication of 250 watts.
- q. Increase RF GAIN (to check ALDC capture). PA OUTPUT indication should remain constant.

Reduce RF drive to minimum and slide Servo Control Drawer back into cabinet. This completes the ALDC adjustment procedure.

#### NOTE

The ALDC adjustments may be set for values LOWER than specified in the procedure if desired.

#### 5-7. POWER LEVEL ADJUSTMENT PROCEDURE

##### Purpose:

The transmitter features four pre-set power levels which are selectable at the front of the transmitter.



These power levels are in four ranges and are selected depending on the position of the POWER LEVEL switch. The specific ranges as set at the factory are as follows; however, other power levels may be set by the customer.

POWER LEVEL POSITION #1	0 - 250 watts
POWER LEVEL POSITION #2	250 - 500 watts
POWER LEVEL POSITION #3	500 - 750 watts
POWER LEVEL POSITION #4	750 - 1000 watts

The following outlined procedural steps are for adjusting and/or calibrating the four power levels.

A. Initial Lower Limit Reference Adjustment

1. Energize transmitter (place MAIN POWER, PLATE and SCREEN breakers to the ON positions. HIGH VOLTAGE MUST BE OFF.
2. Loosen SERVO CONTROL DRAWER panel locks and extend drawer out on its chassis slides and remove top cover.
3. Place a jumper from TP-1 to TP-2 on A207 (A207 located on Servo Control Drawer chassis).
4. Set POWER LEVEL switch to position #1, rotate PWR LEVEL ADJ #1 (located in Servo Control Drawer behind front panel) clockwise until there is no output on meter with MTR CAL switch pushed down. Place AUTO/MANUAL switch to AUTO.
5. Press TUNE button twice.

NOTE

TUNE button is a latching switch and therefore must be pressed twice to set control relays in OPERATE condition.

6. Adjust Level potentiometer (located on PC Assembly A206 in servo control chassis) until READY indicator lights. Press TUNE button twice and readjust Level control in opposite direction slightly until READY indicator goes out. Repeat as often as necessary to obtain a condition that READY indicator does not light when there is no indication on OUTPUT meter.) Before making adjustment TUNE button must be pressed twice.

B. Upper Limit Reference Adjustment

1. Repeat paragraph 5-7A - steps 1, 2 and 3.
2. Set POWER LEVEL switch to position #1. Hold METER CAL button down and press TUNE button twice.
3. While holding METER CAL button down adjust "PWR LEVEL ADJ 1" (located in Servo Control Drawer) counterclockwise until OUTPUT meter indicates full scale deflection (1500 watts).
4. Adjust "MTR CAL ADJ" until READY indicator lights. Press TUNE button twice and observe that READY indicator lights when OUTPUT meter indicates full scale deflection.

5. Adjust "PWR LEVEL ADJ 1" for 500 watt indication on OUTPUT meter, press TUNE button twice and READY indicator should go out.

6. Repeat steps 3 and 4 as often as necessary to obtain optimum results.

#### NOTE

If READY indicator does not go out repeat procedure selecting a different setting on the METER CAL potentiometer to light READY indicator.

7. After adjustments are completed and optimum results are obtained, remove jumper from TP-1 and TP-2. This completes the Upper Limit adjustment.

#### C. Power Level Adjustments

Once the upper and lower reference limits have been calibrated, power levels may be calibrated by holding the METER CAL button down and adjusting the four "PWR LEVEL ADJ" as follows:

Adjust PWR LEVEL ADJ #1 for 250 watts on OUTPUT meter.  
Adjust PWR LEVEL ADJ #2 for 500 watts on OUTPUT meter.  
Adjust PWR LEVEL ADJ #3 for 750 watts on OUTPUT meter.  
Adjust PWR LEVEL ADJ #4 for 1000 watts on OUTPUT meter.

#### NOTE

Motor stopping may tend to over-shoot the desired power level, and it may be necessary to set the levels somewhat lower in order to provide correct motor stopping for the desired output power level.

#### 5-8. TRANSMITTER BIAS ADJUSTMENT PROCEDURE (Refer to Figure 5-5)

The bias adjustments outlined below are to obtain quiescent tube values. Before bias adjustments can be made the Low Voltage Power Supply must be extended out on its slides to expose the bias adjustment potentiometers.

1. Adjust bias controls maximum clockwise (bias voltage will be at maximum value.)

2. Place MAIN POWER, PLATE and SCREEN breakers to the ON position.

3. Set AUTO/MANUAL switch to MANUAL.

4. Insure that RF GAIN control is at minimum (max counter clockwise rotation).

TABLE 5-3. TUBE QUIESCENT CURRENT VALUES

REF SYM	TUBE TYPE	TUBE FUNCTION	QUIESCENT PLATE CURRENT ADJ TO
V1201	8233	1ST AMP	40 ma
V1202	4CX350	2ND AMP	200 ma
V1301	8576	PA	200 ma

NOTE

1. MAX BIAS VOLTAGE WILL BE PRESENT IF:
  - A. BANDSWITCH OR FILTER (OPTIONAL) NOT IN PROPER POSITION.
  - B. PTT RELAY NOT ENERGIZED.
  - C. BIAS CONTROLS ARE AT MAX CLOCKWISE.
2. WHEN MAX BIAS VOLTAGE IS PRESENT AT V1201, V1202, V1301 THE QUIESCENT PLATE CURRENT IS REDUCED TO ZERO WHICH PLACES THE AMPLIFIERS AT OR NEAR CUTOFF.

5. Press HIGH VOLTAGE button to light indicator subsequently applying HIGH VOLTAGE.

6. Observe "Ip" meter and adjust PA BIAS control for an indication 200 ma as read on Ip meter.

7. Hold meter switch "UP" (to 2ND AMP position), observe Ip meter, and adjust 2ND AMP bias control for an indication 200 ma as read on Ip meter.

8. Hold meter switch down (1ST AMP position) observe Ip meter and adjust 1ST AMP bias control for an indication 40 ma as read on the IP meter.

9. Press HIGH VOLTAGE switch to OFF position. (HIGH VOLTAGE indicator must go out.) Slide drawer back to original position.

5-8A. PA SENSE ADJUSTMENT PROCEDURE

Before the sense adjustment can be made the TLAA must be extended out on its slides and the bottom cover removed to expose the sense adjustment potentiometer.

1. Very carefully tune the transmitter manually at a frequency of 2.0 MHz and with an output of 200 watts.

2. Connect a dc voltmeter at the TUN SEN TP-1 on A2 of the AX5130 Servo Control unit. (The VTVM should be set for zero center to observe positive or negative readings.)

3. Observe the VTVM, carefully readjust the transmitter to resonance. (Proper resonance is achieved by rotating the TUNE control so that a peak on the OUTPUT meter corresponds with a dip on the Ip meter.) At resonance the VTVM should read 0 vdc. If required, carefully adjust A1007R8 on the PA sense assembly of the TLAA for 0 vdc reading on the VTVM at resonance.

5-9. AUTO TUNING ADJUSTMENT PROCEDURE (Refer to figure 5-2 and 5-4)

Introduction

The following paragraphs give information for adjusting controls that enable transmitter auto tuning. Bear in mind that, the controls mentioned throughout have previously been set at the factory and therefore need only to be adjusted if abnormalities or parts replacement have taken place.

The transmitter auto-tuning is sequential, extremely rapid, and interdependent on preceding functions that supply control voltages to enable auto tuning. The requirements for auto tuning are RF input from Exciter, AUTO/MANUAL switch in AUTO, High Voltage ON and TUNE BUTTON pressed twice.

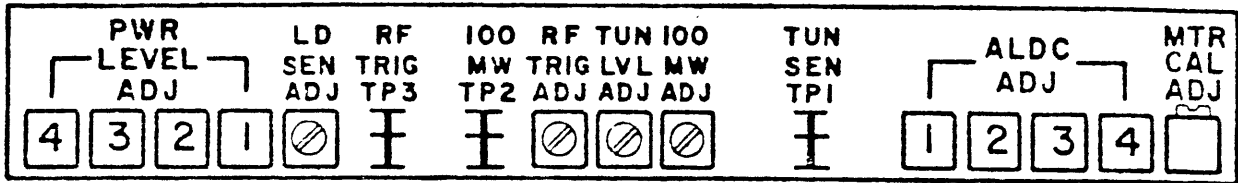

Figure 5-2

Auto Tuning Adjustment Control Location

NOTE

All adjustments in the following procedure(s) enable the transmitters auto tuning circuitry to function normally. Before making any adjustments observe transmitter indicators (meters, lamps, control knobs, breakers, etc.) and refer to the operators section of the associated transmitter manual for the normal transmitter indications. If a transmitter control or indicator does not appear to function normally check all switches and breakers, determine if breakers and switches are in correct position for AUTO-TUNING. Refer to Table 5-4, List of Adjustments and determine which control(s) need adjusting.

TABLE 5-4. LIST OF SERVO TUNING ADJUSTMENTS

<u>Abnormal Observation</u>	<u>Probable Cause</u>
SEARCH lamp does not light	Check exciter RF input at J1004, or check initial tune level adjustment (5-9A).
OPERATE lamp does not light	Check RF Trigger adjustment (para 5-9B)
READY lamp does not light	Check Load Sense adjustment (para 5-9C). Check that servos are turned off, check for sufficient PA output.
PA Plate Current increases from quiescent value to a value other than 300 to 350 ma on initial tune	Check Tune Level adjustment (para 5-9A)
FAULT lamp lights before tuning cycle complete	Check Fault Indication adjustment (para 5-10)

A. Tune Level Adjustment

The TUNE LEVEL control (located in Servo Control Drawer behind front panel) determines the transmitter Plate Current level during initial automatic tuning cycle. When the TUNE LEVEL control is adjusted the voltage present is routed to the RF Gain Motor Control board providing one input, the second input to the motor control is a sample of the PA cathode voltage. The RF Gain Motor Control board compares the levels of the two input voltages, and when either the PA cathode or Tune Level voltage is unequal, the RF Gain Motor Control assembly will control the RF Gain motor, which is mechanically coupled to the RF GAIN control, to increase or decrease the RF drive as necessary to equalize the input voltage levels. Therefore the amount of tune level voltage will determine the tune up level or inhibit auto-tuning if incorrectly adjusted:

When PA Cathode voltage is less than Tune Level voltage, Transmitter Drives-up.

When PA Cathode voltage is greater than Tune Level voltage, Transmitter Drives-down.

When Tune Level Voltage is incorrectly adjusted too high, Transmitter Tuning level high.

When Tune Level voltage is incorrectly adjusted too low, Transmitter Drives down.

When PA Cathode voltage is missing, Transmitter Drives up to limit switch.

When Tune Level voltage is missing, Transmitter Drives-down.

Before attempting to make a Tune Level adjustment proceed as follows:

1. Insure that Transmitter is properly terminated into a 50 ohm dummy load or antenna.

2. Place MAIN POWER breaker, PLATE and SCREEN breakers to their ON positions.

3. Place AUTO/MANUAL switch to MANUAL (RF Drive must be at minimum). Select a carrier frequency of 12 MHz on the associated exciter.

4. Press High Voltage switch to light indicator subsequently applying High Voltage.

5. Check quiescent current values as indicated on the Ip meter. If necessary adjust for the following values.

PA PLATE CURRENT	200 ma
1ST AMP PLATE CURRENT	40 ma
2ND AMP PLATE CURRENT	200 ma

6. Place AUTO/MANUAL switch to AUTO.

7. Press TUNE button twice.

8. Observe the following transmitter actions and/or indicators.

a. PA Plate current increases from quiescent value to 300 to 350 ma.

b. SERVO indicator lights.

c. SEARCH indicator lights.

d. OPERATE lamp lights.

e. All servo indicators on AX5130 go out, and transmitter output power increases to pre-set power level and READY lamp lights.

9. The TUNE LEVEL control must be adjusted only if after the tune button is pressed and PA Plate current meter indicates a value other than 300 to 350 ma.

10. To adjust TUNE LEVEL Control, observe PA Plate current indication, if more or less than 300 to 350 ma, press TUNE button twice to re-cycle Transmitter and adjust TUNE LEVEL control counterclockwise (counterclockwise to increase PA Plate current) or clockwise (clockwise to decrease PA Plate current) to obtain a PA Plate current value of 300 to 350 ma.

NOTE

After each adjustment of the TUNE LEVEL control the TUNE button must be pressed twice to initiate a retune cycle. The adjustment should be repeated as often as necessary to obtain the proper PA Plate current level of 300 to 350 ma.

B. RF Trigger Adjustment

The RF Trigger control determines the amount of voltage required to complete the search mode and begin the servo operate mode. Initially, as the TUNING capacitor approaches resonance and/or zero tune sense voltage, the OPERATE lamp lights indicating resonance and servo mode completed. During the auto tuned cycle of the transmitter if the tuning capacitor continues to rotate (search mode) the OPERATE lamp fails to light, the RF TRIGGER voltage may be insufficient to Trigger the servo mode. To adjust the RF Trigger control proceed as follows:

- a. Connect transmitter output to dummy load and set load control to "0". Set transmitter controls for MANUAL operation.
- b. Plate Test VTVM at TUN SEN TP-1. (Set VTVM for zero center to observe negative or positive reading when tuning control is adjusted through resonance).
- c. Manually adjust RF GAIN control clockwise slightly to apply drive to transmitter and adjust tuning control observing Plate current meter and Test VTVM. Plate current must be at 300 to 350 ma. Test VTVM should indicate approximately zero at resonance.
- d. Once zero indication has been observed plate Test Meter in RF Trigger TP-3 test jack. The RF Trigger Voltage should be .3 VDC.

NOTE

If RF Trigger Voltage is not a .3 VDC adjust RF Trigger control unit Test meter indicates .3 VDC.

Place MANUAL/AUTO switch to AUTO. Press TUNE button twice and observe the following Tune Sequence:

Tune level achieved (Pa plate current 300-350 ma).

SERVO and SEARCH lamp should light.

TUNING control should rotate to point of resonance.

OPERATE lamp should light indicating servo mode ends and operate mode begins.

NOTE

When transmitter is connected into ANTENNA TUNER and the above sequence is not observed, readjust RF Trigger control counterclockwise slightly until sequence is observed.

C. Load Sense Adjustment

The LOAD SENSE control is used to adjust the position of the LOAD capacitor for correct loading. When the transmitter is in the AUTO mode of operation the LOAD capacitor rotates to minimum capacitance after SEARCH lamp lights. During transmitter loading the LOAD capacitor rotates toward maximum capacitance and stops when loading is correct.

A condition of NO loading will be noted by the following:

(A) LOAD capacitor does not rotate clockwise after READY lamp lights.

(B) Excessive PA Plate Current and insufficient PA OUTPUT.

(C) Fault lamp lights after approximately 30 seconds.

Should it become necessary to adjust the LOAD SENSE control proceed in the following manner:

(1) Connect transmitter to dummy load.

(2) Energize transmitter (MAIN POWER, SCREEN AND PLATE BREAKERS to ON). H.V. switch pressed to ON.

(3) Place MANUAL/AUTO switch to MANUAL. POWER LEVEL switch to position 4. Turn LOAD SENSE adjust fully clockwise (LOAD SENSE ADJ located in servo control drawer).

(4) At 12 MHz operate TUNE and LOAD control to produce the maximum PA OUTPUT with the least amount of PA Plate Current.

(5) Increase RF DRIVE until PA OUTPUT meter indicates rated output. (Note setting of LOAD capacitor)

(6) Reduce PA OUTPUT until PLATE current meter indicates 300-350ma.

(7) Slide AX5130 unit out on its chassis slides to expose LOAD SENSE adjustment control. (Refer to figure 5-2 for control location.) Adjust LOAD SENSE control until voltage on A205 TP-1 and TP-2 are equal.

(8) Place MANUAL/AUTO switch in AUTO press TUNE button twice.



### NOTE

LOAD setting should be as noted in step 5. If not, turn LOAD SENSE control ccw to increase setting or cw to decrease setting. Load setting may have to be readjusted when transmitter is connected into ANTENNA TUNER.

Transmitter indicator lamps and meter indicator should indicate in the following sequence:

PA Quiescent current 220 ma as read on Ip meter.

PA Plate Current indicator increases to 300 to 350 ma.

Servo lamp lights.

SEARCH lamp followed by OPERATE lamp lights.

Transmitter output indication increases to rated or preset output and READY lamp lights.

### 5-10. FAULT INDICATION ADJUSTMENT PROCEDURE

#### Introduction

The transmitter is designed to servo tune to rated or pre-selected output in less than 5 seconds. The fault circuit featured in the transmitter, senses the transmitter tuning time and will remove voltages to the servo amplifiers, RF drive motor and bias the transmitter at or near cutoff if the transmitter has not completed the tuning cycle within the duration of time affixed by the following adjustment.

1. Extend Servo Control drawer out on its slides and remove top cover.
2. Remove the exciter RF input cable from TLAA-1K. Place MANUAL-AUTO switch to AUTO. (RF input cable must be reconnected after adjustment is completed)
3. Place MAIN POWER, PLATE and SCREEN breakers to their ON positions.
4. Press HIGH VOLTAGE switch to light indicator.
5. Press TUNE switch twice. After approximately 30 seconds the FAULT indicator should light.
6. If the FAULT lamp does not light within 30 seconds, adjust R4 on A209 until FAULT indicator lights 30 seconds after TUNE button is pressed. (Repeat the adjustment as often as necessary to obtain optimum results.)
7. Press HIGH VOLTAGE switch to OFF, (H.V. Indicator OUT).
8. Affix top cover to Servo Control drawer and slide drawer back to its original position. This completes the FAULT indicator Adjustment procedure.

## 5-11. OVERLOAD CIRCUIT TEST

### a. Purpose

The Overload Circuitry functions to protect the HFLA-1K against possible excessive current and VSWR overloads. To set and/or check the overloads perform the following.

- (1) Energize Transmitter (MAIN POWER breaker ON, PLATE SCREEN breaker ON).
- (2) MANUAL/AUTO switch to MANUAL, POWER LEVEL switch to position 4.
- (3) Loosen panel locks and extend low voltage drawer out on its slides to expose bias controls.
- (4) Press HIGH VOLTAGE switch to ON (HIGH VOLTAGE indicator should light).

### NOTE

When overload occurs, HIGH VOLTAGE switch must be pressed twice to re-apply high voltage. Press to reset overload and press to apply high voltage.

## 5-12. PA PLATE OVERLOAD ADJUSTMENT

- Step 1 Adjust Overload indicator (adjustment screw (part of meter) located directly below meter face) for 300 ma as indicated on PLATE current meter.
- Step 2 Adjust PA Bias control counterclockwise until PLATE current meter indicates 300 ma. Observe the following:
- a. When meter indicator reaches the value of overload indicator setting, the high voltage will trip off.
  - b. PLATE current ( $I_p$ ) meter face will illuminate, indicating overload in plate current.
  - c. Meter indicator will remain at the overload value to indicate which caused overloaded condition.
- Step 3 Readjust bias to maximum clockwise position and press HIGH VOLTAGE pushbutton to reset high voltage. (H.V. Switch must be pressed twice).
- Step 4 To check further operation of plate overload, adjust bias control counterclockwise again, noting that high voltage tripped as in Step 2; set overload indicator for indication of 800 ma. Readjust PA bias control for 200 ma as indicated on the  $I_p$  meter.

## 5-13. 2ND AMPLIFIER PLATE OVERLOAD ADJUSTMENT (Refer to Figure 5-8)

- Step 1 Extend TLAA out on its slides to expose the 2nd Amp and SWR overload adjustment control.
- Step 2 Push "PLATE meter switch" up and observe 2ND AMP plate current.
- Step 3 Adjust 2ND BIAS control counterclockwise until 2ND AMP plate current indicates 400 ma.
- Step 4 Adjust 2ND AMP PLATE OVERLOAD potentiometer until high voltage trips off (located on bottom of TLAA-1K).

- a. PLATE current meter will illuminate, indicating overload in 2ND AMP plate current.
- b. High voltage will trip OFF, HIGH VOLTAGE Indicator will go out.
- c. PLATE current meter will indicate zero.

Step 5 Readjust 2ND AMP BIAS control to maximum clockwise position and press HIGH VOLTAGE pushbutton to reset high voltage (HIGH VOLTAGE switch must be pressed twice).

Step 6 To check further operation of 2ND AMP PLATE OVERLOAD, readjust bias control counterclockwise again, noting that high voltage tripped as in Step 4.

Step 7 Reset bias control for a 2ND amp plate current reading of 200 ma.

#### 5-14. SWR OVERLOAD ADJUSTMENT (Refer to Figure 5-8)

Step 1 Tune transmitter into a 50 ohm dummy load at a frequency of 12 MHz.

Step 2 Remove HIGH VOLTAGE. Disconnect antenna or dummy load.

Step 3 Press HIGH VOLTAGE pushbutton to apply high voltage.

Step 4 Push SWR pushbutton and carefully increase drive until a reading of 250 watts on KILOWATT meter, is observed on the reflected power scale.

Step 5 Adjust SWR potentiometer until high voltage trips OFF (located on bottom of TLAA-1K.)

- a. The OUTPUT meter will illuminate
- b. High voltage will trip OFF; HIGH VOLTAGE indicator will go out.
- c. PLATE current meter will indicate zero.
- d. To further check operation of SWR overload, reduce RF Drive, press HIGH VOLTAGE pushbutton to ON and increase RF Drive again until overload trips HIGH VOLTAGE OFF.

#### NOTE

For SWR settings other than 2:1, refer to Figure 5-3.

POWER VALUES vs. VSWR

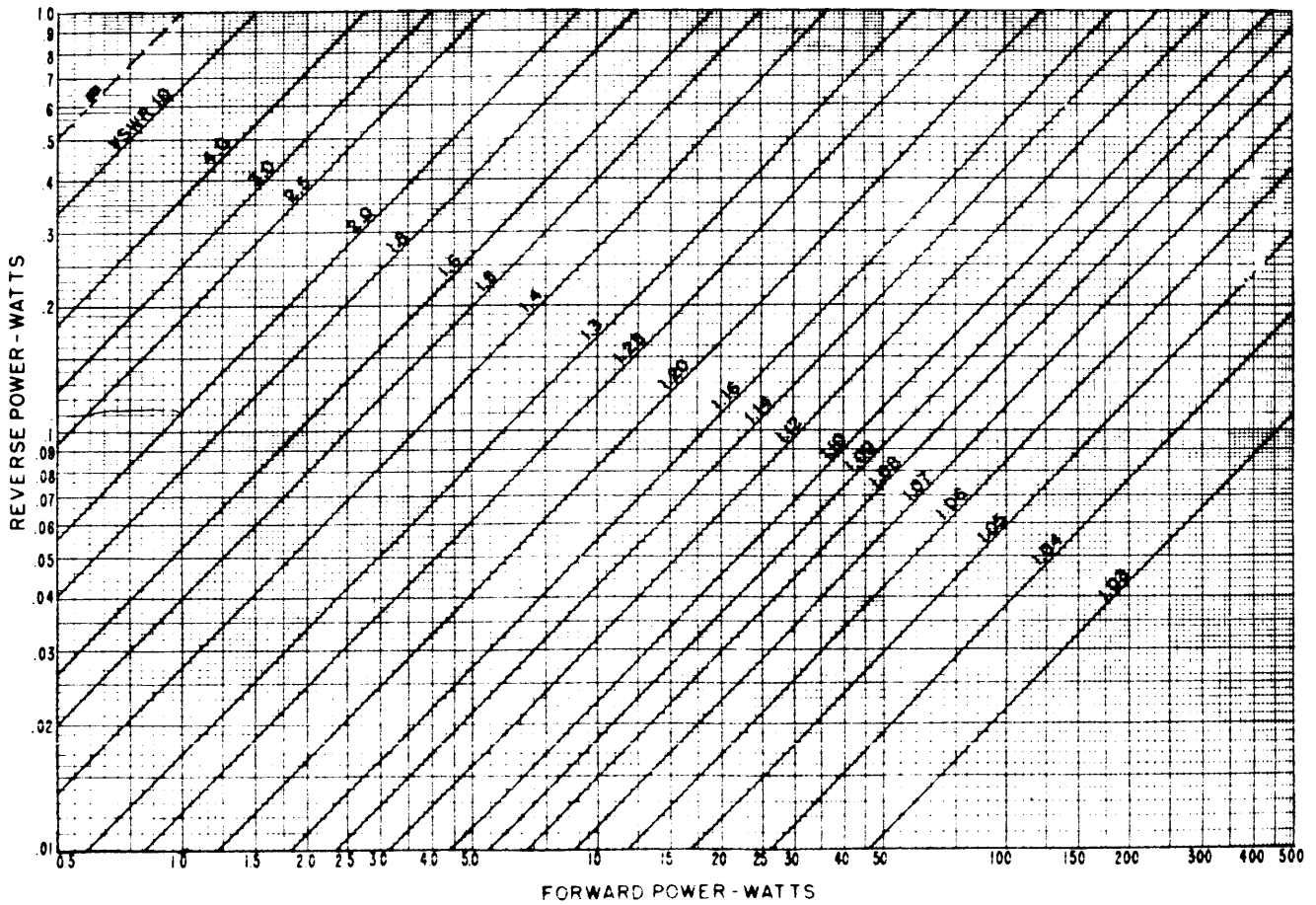
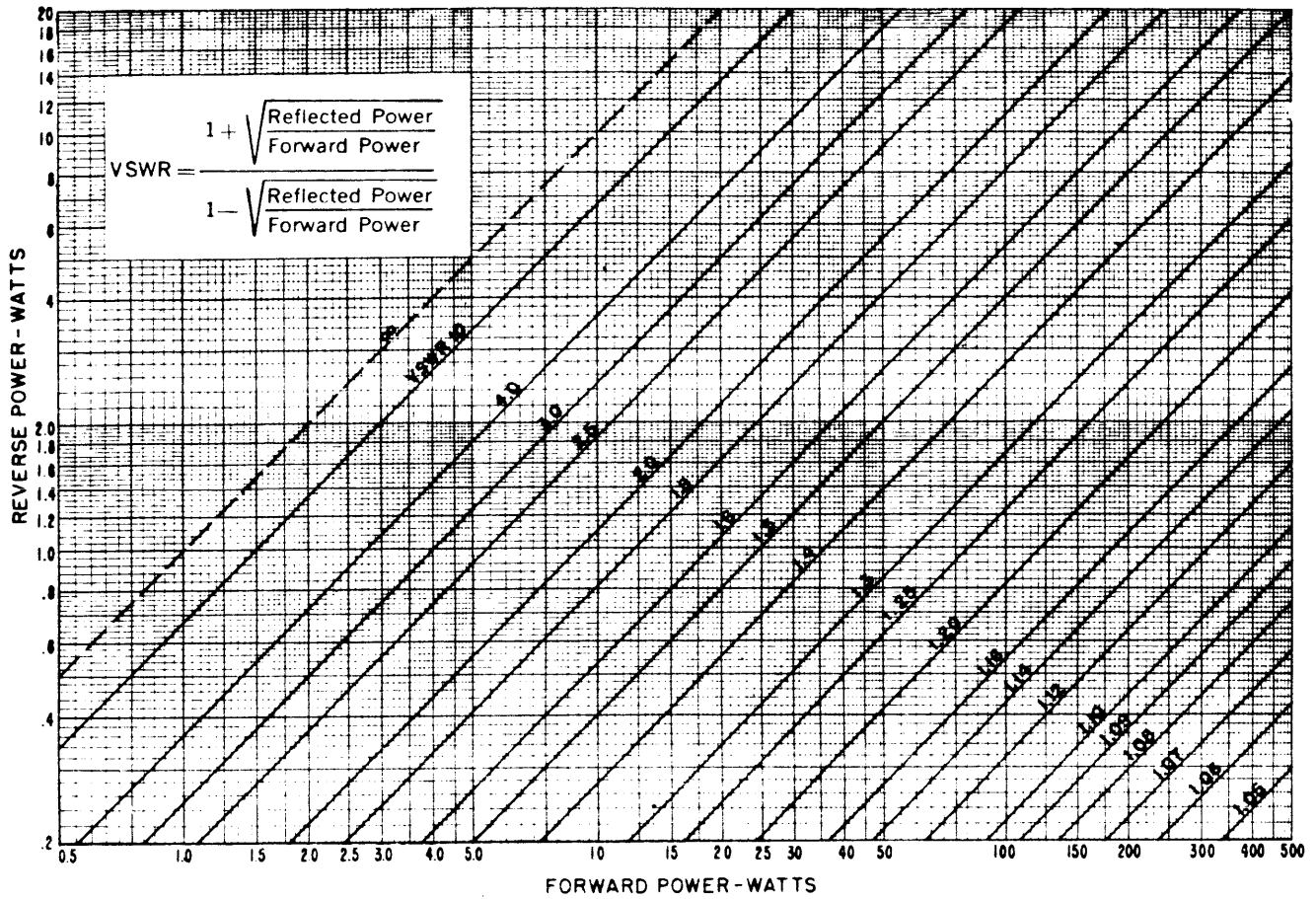

Figure 5-3. VSWR Nomograph

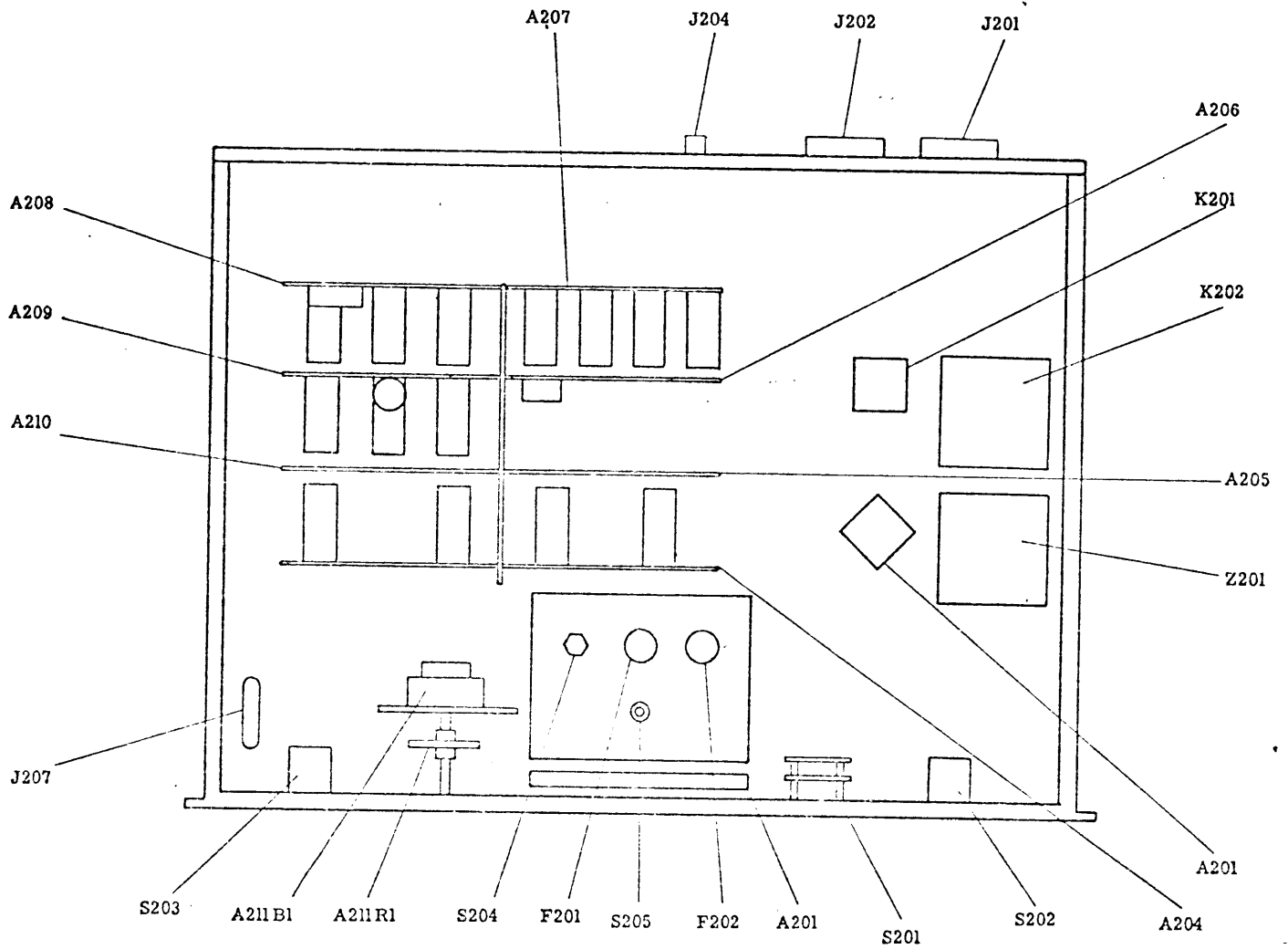

Figure 5-4. AX-5130 Top View

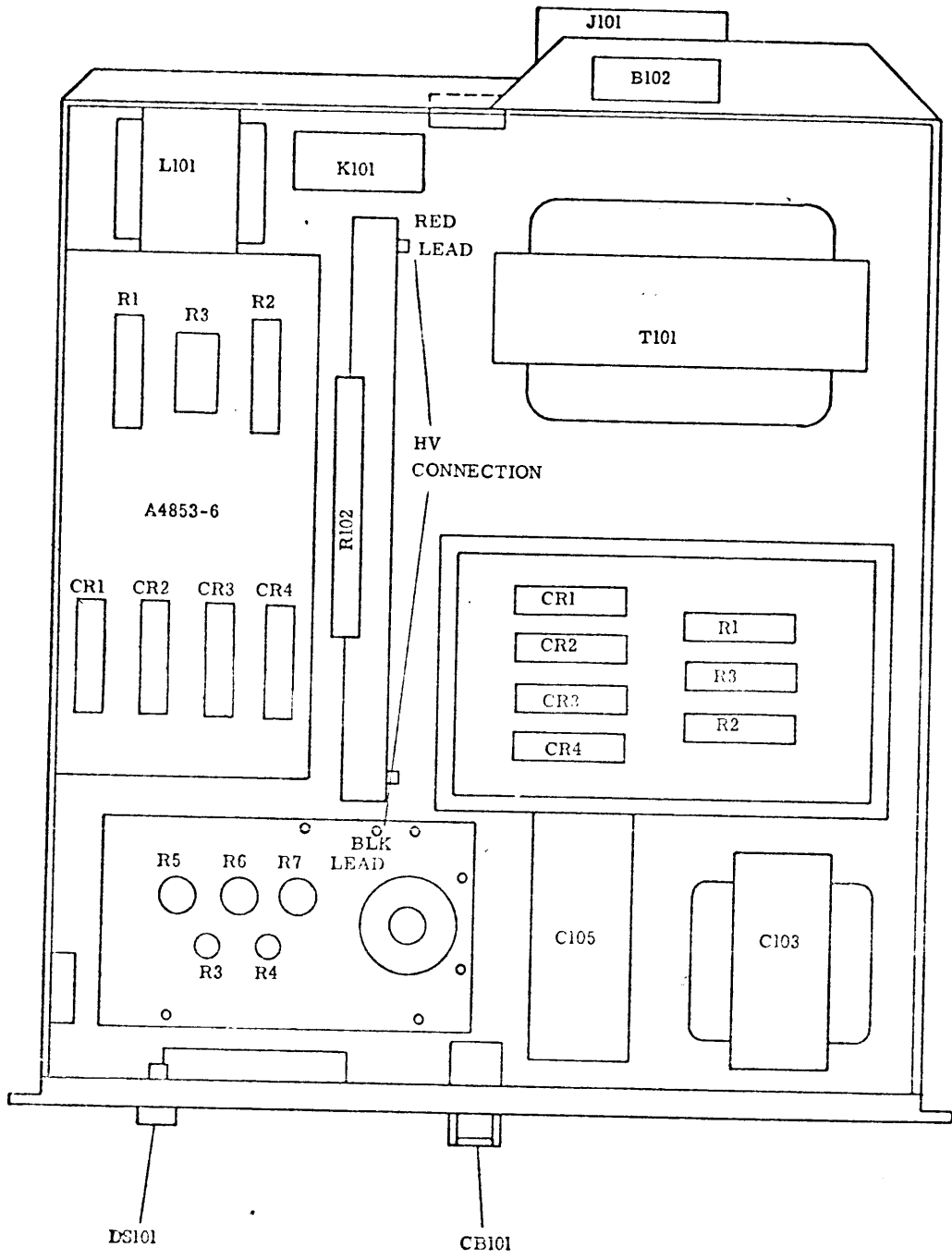

Figure 5-5. AP-152 Top View

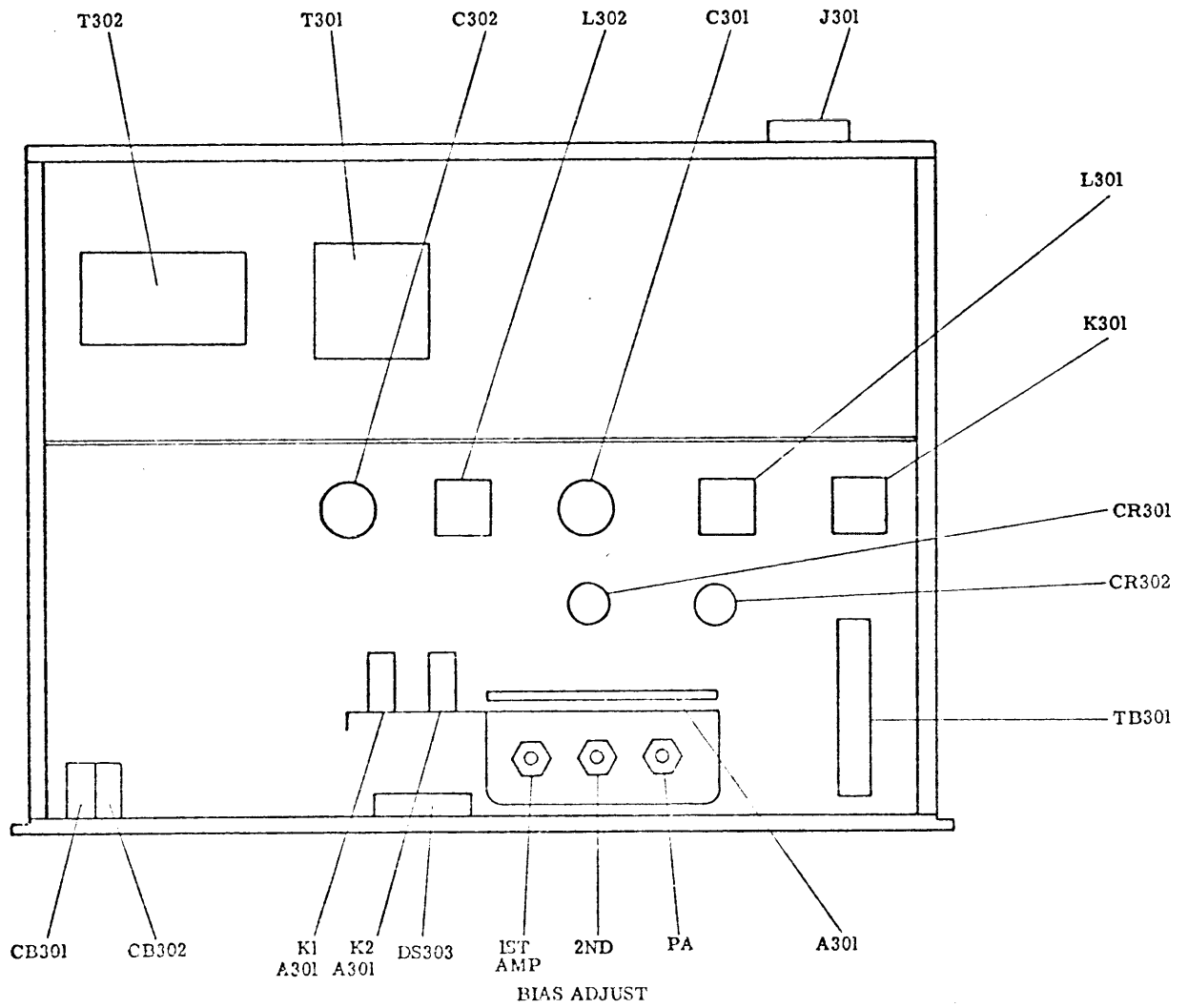

Figure 5-6. AP-151 Top View

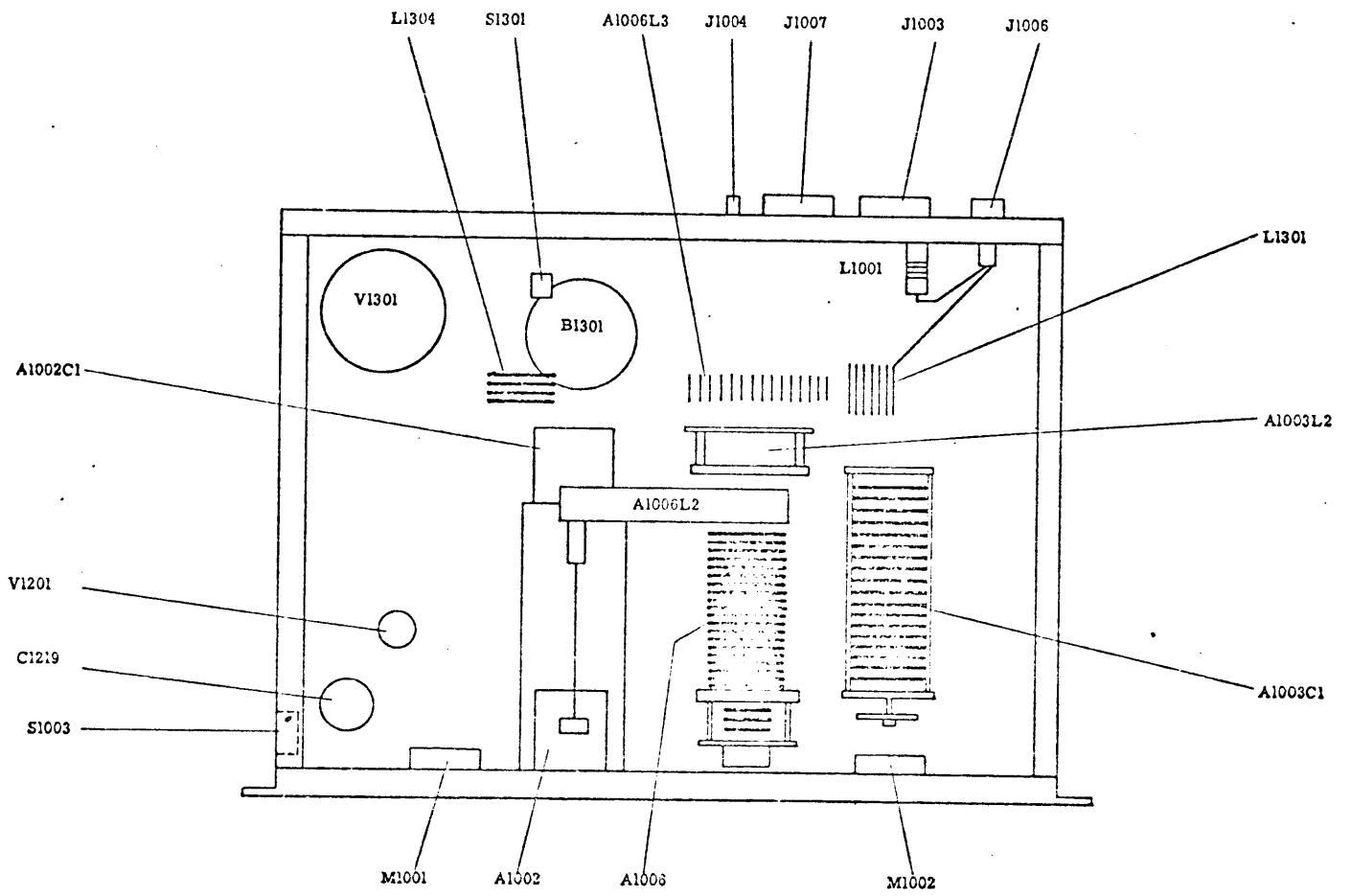

Figure 5-7. TLA-1K Top View



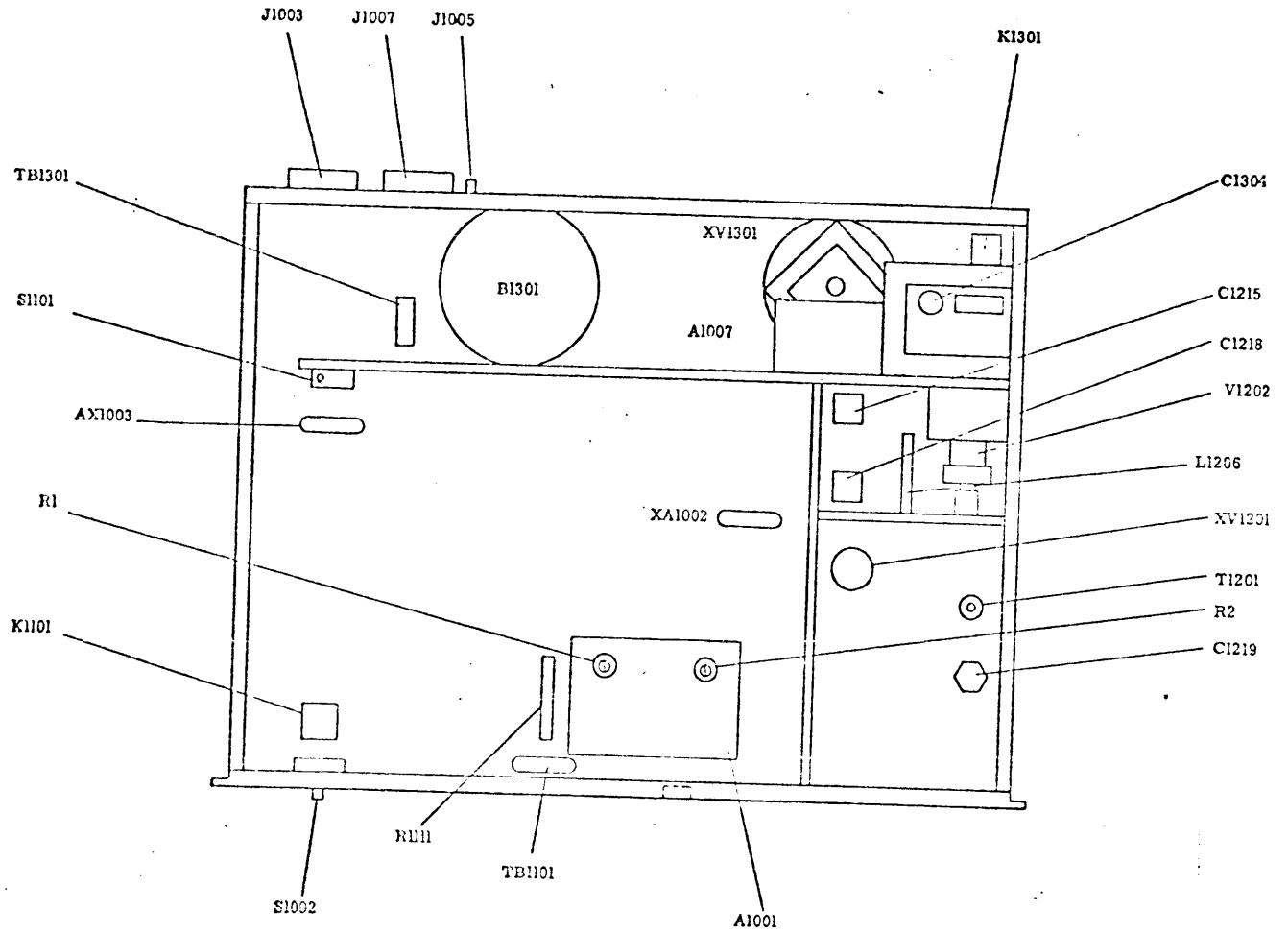

Figure 5-8. TLA-1K Bottom View

SECTION 6

PARTS LIST

6-1. INTRODUCTION

Reference designations have been assigned to identify all electrical parts of the equipment. These designations are used for marking the equipment (adjacent to the part they identify) and are included on drawings, diagrams and the parts list. The letters of a reference designation indicate the kind of part (generic group), such as resistor, capacitor, transistor, etc. The number differentiates between parts of the same generic group. Sockets associated with a particular plug-in device, such as transistor or fuse, are identified by a reference designation which includes the reference designation of the plug-in device. For example, the socket for relay K201 is designated XK201. The assemblies and/or sub-assemblies that are a part of a major assembly are suffixed with an asterisk; parts list breakdown for these assemblies are located in the rear of the parts section. For example, in parts list for Power Amplifier, the Reference Symbol A1001 shows a TMC part number A4879\*, the parts list breakdown for A4879 is located in the rear of parts list for TLAA-1K. To expedite delivery when ordering replacement parts, specify the TMC part number and the model number of the equipment. See example below.

To order C1 of A4879, order as follows:

A4879 C1, TMC Part No. CX119-104M.

<u>Title</u>	<u>Page</u>
H.V. Power Supply AP152 (Symbol Series 100) . . . . .	6-2
Servo Control Drawer AX5130 (Symbol Series 200) . . . . .	6-4
L.V. and Bias Supply AP151 (Symbol Series 300) . . . . .	6-19
RF Linear Power Amplifier TLAA-1K (Symbol Series 1000) . . . . .	6-22

AP152 H/V Power Supply

REF SYMBOL	DESCRIPTION	TMC PART NUMBER
A101	Assembly, PC, Board, Rect	A-4853-6*
A102	Assembly, PC, Board, Rect	A-4853-7*
A103	Assembly, PC, Board, Zener	<b>A-5637</b>
B101	Fan, Vent	BL106-2
B102	Same as B101	
C101	Capacitor, Fixed, Film	<b>CN128-1</b>
C102 thru C104	Same as C101	
C105	Capacitor, Fixed, Paper	CP70B1EG106K
CB101	Circuit, Breaker	SW261
DS101	Lamp, Incand	BI105-1
DS102	Same as DS101	
F101	Fuse, Circuit	FU102-.500
K101	Rel, Arm	RL184-3
L101	React, 5H	TF5034
L102 thru L104	Same as L101	
R101	Res, Fixed, WW 160W	RW117-39
R102	Same as R101	
R103	Resistor, Fxd, WW 55W	RW115-101-55
T101	Xfmr, Pl	TF413
TB101	Terminal, Bd, Barr	TM102-4
XDS101	Socket, Lamp	TS136-2FS
XDS102	Socket, Lamp	TS136-1FS
XF101	Fuse holder	FH105
XK101	Soc, Rel	TS196-1
Z101	Shunt, Circuit, Breaker	AR196
Z102	Shunt, Circuit, Breaker	AR197

AP152 H/V Power Supply (con't)

REF SYMBOL	DESCRIPTION	TMC PART NUMBER
A-4853-6 Assembly, Board, PC Rect		
A101CR1 thru A101CR4	Rect, Scond, Dev	DD140
A101R1	Resistor, Fixed, WW 10W	RW109-4
A101R2	Same as A101R1	
A101R3	Resistor, Fixed, WW 20W	RW110-3
A-4853-7 Assembly, Board, PC Rect		
A102CR1 thru A102CR4	Rect, Scond, Dev	DD140
A102R1	Resistor, Fixed, WW 10W	RW109-4
A102R2	Same as A102R1	
A102R3	Resistor, Fixed, WW 20W	RW110-7
A5637 Assembly, Board, PC Zener		
A103CR1	Scond, Dev, Dio	1N2846A
A103CR2	Same as A103CR1	
A103R1	Resistor, Fixed, Comp	RC42GF274J
A103R2	Resistor, Fixed, Comp	RC42GF124J
A103R3	Resistor, Fixed, Comp	RC42GF101J
A103R4	Resistor, Fixed WW 50W	RW105-35
A103R5	SAME AS A103R4	
A103R6	Same As A103R4	
A103R8	Same As A103R3	
A103R9	SAME AS A103R3	

AX5130 Servo Control Drawer

REF SYMBOL	DESCRIPTION	TMC PART NUMBER
A201	ALDC Control	A-4856-2*
A202	Board, PC Level Adjust	A-4876*
A203	Board, PC, Interconnect	A-4883*
A204	Board, PC, Channel	A-4873*
A205	Board, PC, Load Adjust	A-4886*
A206	Board, PC, Output Control	A-4880*
A207	Board, PC, Servo Control	A-4871*
A208	Board, PC, Servo	A-4870*
A209	Board, PC, Servo Recycle	A-4869*
A210	Board, PC, Gain Control	A-4872*
A211	Assembly, RF Gain Control	BMA466*
C201	Capacitor, Fixed, Ceramic	CC100-40
C202	Capacitor, Fixed, Paper	CX131
C203	Capacitor, Fixed, Ceramic	CN114-10R0-2JF
C204	Same as C203	
C205	Capacitor, Fxd, Elec	CE105-50-25
DS201	Not used	
DS202	Lamp, Ind, Min	BI110-7
DS203	Same as DS202	
E201	Terminal, Turret	TE102-2
F201	Fuse, Slo-Blow	FU102-.5
F202	Same as F201	
F203	Fuse, Slo-Blow	FU102-.2
F204	Same as F203	
K201	Relay, Arm	RL168-3C10-24
R201	Res, Fxd, Comp	DC RC07GF105J
R202	Res, Fxd, Comp	RC07GF681J

AX5130 Servo Control Drawer (con't)

REF SYMBOL	DESCRIPTION	TMC PART NUMBER
R203	Res, Fxd, Comp	RC07GF822J
R204	Res, Fxd, Comp	RC42GF151J
R205	Res, Fxd, Comp	RC20GF224J
R206	Res, Fxd, Comp	RC32GF221J
R207	Res, Fxd, Comp	RC32GF681J
R208	Res, Fxd, Comp	RC32GF182J
S201	Switch, Rotary	SW106
S202	Switch, Push	SW522-1
S203	Same as S202	
S204	Switch, Toggle	ST103-5-62
S205	Switch, Push Button	SW296-1
XA201	Socket, Elec	TS100-3
XA202	Conn, RECEP, Elec	JJ319-22DFE
XA203A	Same as XA202	
XA203B	Same as XA202	
XA204	Conn, RECEP, ELEC	JJ319-22DPE
XF201	Holder, Fuse, Ind	FH104-4
XF202	Same as XF201	
XF203	Holder, Fuse, Ind	FH104-3
XF204	Same as XF203	
XK201	Socket, Elec	TS100-5
Z201	Servo, Amp	NW181
Z202	Servo, Amp	NW182

A-4856-2 ALDC CAN

REF SYMBOL	DESCRIPTION	TMC PART NUMBER
R1	Resistor, Fixed, Comp	RC07GF221J
R2	Resistor, Fixed, Comp	RC07GF474J
R3	Resistor, Fixed, Comp	RC07GF101J
R4	Resistor, Fixed, Comp	RC07GF682J
R5	Same as R1	
R6	Resistor, Fixed, Comp	RC07GF471J
R30	Resistor, Fixed, Comp	RC07GF822J
A-4855 ALDC Printed Circuit Board		
C1	Capacitor, Fixed, Elect	CE105-75-25
C2 thru C4	Capacitor, Fixed, Cer	CC100-9
C5	Same as C1	
C6 thru C10	Same as C2	
C11	Capacitor, Fixed, Elect	CE105-6-15
C12	Same as C2	
C13	Same as C2	
C14	Capacitor, Fixed, Elect	CE105-1-15
CR1	Semicond, Diode	1N277
CR2	Semicond, Diode	1N759A
CR3	Same as CR2	
R1 thru R6	Not Used	
R7	Resistor, Fixed, Comp	RC07GF471J

A-4855 ALDC Printed Circuit Board (con't)

REF SYMBOL	DESCRIPTION	TMC PART NUMBER
R8	Resistor, Fixed, Comp	RC07GF221J
R9	Resistor, Fixed, Comp	RC07GF682J
R10	Resistor, Fixed, Comp	RC07GF101J
R11	Resistor, Fixed, Comp	RC07GF223J
R12	Resistor, Fixed, Comp	RC07GF181J
R13	Resistor, Fixed, Comp	RC07GF474J
R14	Resistor, Fixed, Comp	RC07GF102J
R15	Resistor, Fixed, Comp	RC07GF224J
R16	Resistor, Fixed, Comp	RC07GF152J
R17	Resistor, Fixed, Comp	RC07GF333J
R18	Resistor, Variable	RV124-1-502K
R19	Resistor, Fixed, Comp	RC07GF153J
R20	Resistor, Fixed, Comp	RC07GF562J
R21	Resistor, Fixed, Comp	RC07GF103J
R22	Same as R14	
R23	Same as R19	
R24	Same as R18	
R25	Same as R17	
R26	Same as R16	
R27	Resistor, Fixed, Comp	RC07GF183J
R28	Resistor, Fixed, Comp	RC07GF472J
R29	Same as R14	
Z1	Operational, Amp	NW156
Z2	Same as Z1	



A-4876 Board, Assembly, PC Level Adjust

REF SYMBOL	DESCRIPTION	TMC PART NUMBER
C1	Capacitor, Fixed, Cer	CC100-41
C2	Same as C1	
C3	Capacitor, Fixed, Cer	CC100-44
CR1	Scond, Dev, Dio	1N34A
CR2	Scond, Dev, Dio	1N3022B
DS1 thru DS4	Lamp, Incand	BI114-2
R1	Resistor, Var, Comp	RV119-1-503-B
R2 thru R4	Resistor, Var, WW	RV121-1-501
R5	Same as R2	
R6	Resistor, Var, WW	RV121-1-103
R7	Same as R2	
R8	Same as R6	
R9	Resistor, Var, WW	RV115-1-503
R10 thru R13	Resistor, Var, WW	RV121-1-502
R14	Resistor, Fixed, Comp	RC32GF271J
R15 thru R17	Resistor, Fixed, Comp	RC32GF391J
R18	Resistor, Fixed, Comp	RC20GF471J
R19	Resistor, Fixed, Comp	RC20GF223J
R20	Resistor, Fixed, Comp	RC20GF103J
R21	Resistor, Fixed, Comp	RC42GF221J

A-4876 Board, Assembly, PC Level Adjust (continued)

REF SYMBOL	DESCRIPTION	TMC PART NUMBER
R22	Resistor, Fixed, Comp	RC20GF563J
R23	Same as R20	
TP1 thru TP3	Terminal, Stud	TE127-9

A-4883 Board, Assembly, PC Interconnect

REF SYMBOL	DESCRIPTION	TMC PART NUMBER
XA205 thru XA210	Conn, Recep, Elec	JJ319-22DPD

A-4886 Board, Assembly Load Adjust

REF SYMBOL	DESCRIPTION	TMC PART NUMBER
C1	Capacitor, Fixed, Elec	CE105-25-15
C2	Same as C1	
C3	Capacitor, Fixed, Elec	CE105-75-25
C4 thru C6	Capacitor, Fixed, Cer	CC100-44
CR1	Scond, Dev, Dio	1N645
CR2	Same as CR1	
CR3	Scond, Dev, Dio	1N277
CR4	Same as CR1	
CR5	Same as CR1	
K1	Rel, Arm, 4PDT	RL156-15
K2	Same as K1	
Q1	Scond, Dev, TSTR	2N1711
Q2	Same as Q1	
Q3	Scond, Dev, TSTR	2N4036
R1	Resistor, Fixed, Comp	RC07GF392J
R2	Resistor, Fixed, Comp	RC07GF332J
R3	Resistor, Fixed, Comp	RC07GF822J
R4	Resistor, Fixed, Comp	RC07GF153J
R5	Resistor, Fixed, Comp	RC07GF221J
R6	Resistor, Fixed, Comp	RC07GF472J
R7	Resistor, Fixed, Comp	RC07GF222J
R8	Same as R2	
TP1	Terminal, Stud	TE127-2
TP2	Same as TP1	

A-4886 Board, Assembly, Load Adjust (con't)

REF SYMBOL	DESCRIPTION	TMC PART NUMBER
XK1	Socket, Relay	TS171-4
XK2	Same as XK1	

A-4880 Board, Assembly, PC Output Control

REF SYMBOL	DESCRIPTION	TMC PART NUMBER
R1	Resistor, Fixed, Comp	RC07GF332J
Z1	Network, Comparator	NW 161

A-4871 Board, Assembly PC, Servo Control

REF SYMBOL	DESCRIPTION	TMC PART NUMBER
C1	Capacitor, Fixed, Cer	CC100-44
C2	Same as C1	
CR1 thru CR10	Scnd, Dev, Dio	1N645
K1	Rel, Arm 4PDT	RL156-10
K2	Same as K1	
K3	Rel, Arm, 4PDT	RL156-15
K4	Same as K1	
K5	Same as K1	
Q1	Scnd, Dev, Dio	2N697
Q2	Same as Q1	
R1	Resistor, Fixed, Comp	RC07GF153J
R2	Resistor, Fixed, Comp	RC07GF332J
R3	Same as R1	
R4	Same as R2	
TP1	Terminal, Stud	TE127-2
TP2	Same as TP1	
XK1 thru XK5	Socket, Relay	TS171-4
Z1	Network, TD	NW179-24-0.5S

A-4870 Board, Assembly, PC Servo

REF SYMBOL	DESCRIPTION	TMC PART NUMBER
C1	Capacitor, Fixed, Cer	CC100-35
C2	Same as C1	
C3	Capacitor, Fixed, Elec	CE105-3-25
C4	Same as C3	
C5	Capacitor, Fixed, Elec	CE105-150-75
CR1	Rect, Scond, Dev	DD130-100-1.5
K1	Rel, Arm , DPDT	RL156-15
K2	Same as K1	
K3	Rel, Arm DPDT	RL156-4
K4	Rel, Arm DPDT	RL156-9
R1	Resistor, Fixed, Comp	RC07GF104J
R2	Resistor, Fixed, Comp	RC07GF472J
R3	Resistor, Fixed, Comp	RC07GF393J
R4	Same as R2	
R5	Same as R1	
XK1	Socket, Relay	TS171-4
XK2	Same as XK1	
XK3	Socket, Relay	TS171-5
XK4	Same as XK3	



A-4869 Board, Assembly, PC Servo Re-Cycle

REF SYMBOL	DESCRIPTION	TMC PART NUMBER
C1	Capacitor, Fixed, Elec	CE105-100-25
C2	Capacitor, Fixed, Elec	CE105-150-75
CR1	Scond, Dev, Dio	1N645
CR2	Scond, Dev, Dio	1N2484
CR3	Same as CR2	
K1	Rel, Arm DPDT	RL156-1
K2	Rel, Arm 4PDT	RL156-15
K3	Same as K2	
K4	Rel, Arm, DPDT	RL156-9
K5	Same as K1	
Q1	Scond, Dev, TSTR	2N492
R1	Resistor, Fixed, Comp	RC20GF221J
R2	Resistor, Fixed, Comp	RC32GF221J
R3	Same as R2	
R4	Resistor, Var, Comp	RV111254A
XK1	Socket, Relay	TS171-5
XK2	Socket, Relay	TS171-4
XK3	Same as XK2	
XK4	Same as XK1	
XK5	Same as XK1	

A-4872 Board, Assembly, PC Gain Control

REF SYMBOL	DESCRIPTION	TMC PART NUMBER
C1 thru C4	Capacitor, Fixed, Elec	CE105-25-25
C5 thru C7	Capacitor, Fixed, Cer	CC100-44
C8	Capacitor, Fixed, Elec	CE105-200-25
CR1 thru CR3	Scnd, Dev, Dio	1N645
CR4	Scnd, Dev, Dio	1N277
CR5	Same as CR4	
CR6	Same as CR1	
K1	Rel, Arm, 4DPT	RL156-15
K2	Same as K1	
Q1	Scnd, Dev, TSTR	2N1711
Q2	Same as Q1	
Q3	Scnd, Dev, TSTR	2N4036
Q4	Same as Q3	
R1	Resistor, Fixed, Comp	RC07GF392J
R2	Same as R1	
R3	Resistor, Fixed, Comp	RC07GF822J
R4	Same as R3	
TP1	Terminal, Stud	TE127-2
TP2	Same as TP1	
XK1	Socket, Relay	TS171-4
XK2	Same as XK1	

BMA 466 R.F. Gain Control

REF SYMBOL	DESCRIPTION	TMC PART NUMBER
B1	Motor	M0136-10-UH-F
C1	Capacitor, Fixed, Mylar	CN1141R04J
E1	Terminal, Turret	TE102-2
E2	Same as E1	
R1	Resistor, Var, Comp	RV4NAYSK102C
R2	Resistor, Fixed, WW	RW107-28
S1	Switch, Sen	SW353-3
S2	Same as S1	
S3	Switch, Sem	SW353-2

AP151 L/V and Bias Supply

REF SYMBOL	DESCRIPTION	TMC PART NUMBER
A301	Board, Assembly, Pc, Bias	A-4877*
C301	Capacitor, Fixed, Elec	CE52C200Q
C302	Same as C301	
C303	Capacitor, Fixed, Elec	CE116-8VN
C304	Same as C303	
CB301	Circuit, Breaker	SW262
CB302	Circuit, Breaker	SW215
CR301	Scnd, Dev, Dio	1N2843RA
CR302	Scnd, Dev, Dio	1N2831RA
CR303	Scnd, Rect	RX108-2
CR304	Scnd, Dev, Dio	1N3321B
CR305	Scnd, Dev, Dio	1N3324B
DS301	Lamp, Incand	BI110-7
DS302	Same as DS301	
DS303	Gen, Audio, Sig.	BZ101-2
F301	Fuse, Cartridge (115V operation only)	FU102-1.5
F301	Fuse, Cartridge (230V operation only)	FU102-.75
F302	Fuse, Cartridge (115V operation only)	FU102-2
F302	Fuse, Cartridge (230V operation only)	FU102-1
F303	Same as F301	
F304	Fuse, Cartridge	FU102-.2
F305	Fuse, Cartridge	FU100-4
F306	Fuse, Cartridge	FU102-2.5
J301	Conn, Recep, ML	MS3102A32-414P
K301	Rel, Arm.	RL168-3C10-24DC
L301	React. 5H	TF5028
L302	Same as L301	
R301	Res, Fxd, WW 10W	RW109-19
R302	Res, Fxd, Comp	RC42GF474J
R303	Res, Fxd, Comp	RC20GF103J
R304	Res, Fxd, WW 10W	RW109-1
R305	Same as R304	
R306	Res, Fxd, WW 20W	RW110-5

AP151 L/V and Bias Supply

REF SYMBOL	DESCRIPTION	TMC PART NUMBER
R307	Same as R304	
R308	Res, Fxd, Comp	RC42GF392J
R309	Res, Fxd, WW 20W	RW110-5
R310	Res, Fxd, Comp	RC42GF101J
R311	Same as R310	
R312	Same as R309	
S301	Switch, Toggle, SPST	ST103-5-62
S302	Switch, Push, DPDT	SW522-1
T301	Transformer, Fil	TF414
T302	Transformer, L/V	TF416
TB301	Terminal, Strip, Barr	TM100-8
XA301	Conn, Pc, Board	JJ319-22DFE
XC301	Socket, Octal	TS101P01
XC302	Same as XC301	
XCR301	Soc, Scond, Dev	TS166-1
XCR302	Same as XCR301	
XDS301	Light, Ind	TS153-11
XDS302	Light, Ind	TS184
XF301	Fuseholder	FH104-3
XF302	Same as XF301	FH104-3
XF303	Same as XF301	
XF304	Same as XF301	
XF305	Fuseholder	FH104-11
XF306	Same as XF305	
XK301	Same as XC301	

A-4877 Board, Assembly, PC Bias

REF SYMBOL	DESCRIPTION	TMC PART NUMBER
CR1	Rect, Scond, Dev	DD130-600-1.5
CR2	Scond, Dev, Dio	1N645
CR3 thru CR10	Same as CR2	
K1	Rel, Arm 4PDT	RL156-15
K2	Rel, Arm 4PDT	RL156-10
R1	Res, Fxd, Comp	RC42GF100J
R2	Same as R1	
R3	Res, Fxd, Comp	RC42GF122J
R4	Res, Var, Comp	RV4LAYS252A
R5	Res, Fxd, Comp	RC42GF101J
R6	Res, Fxd, Comp	RC42GF332J
R7	Res, Var, Comp	RV4LAYS502A
R8	Res, Fxd, Comp	RC42GF151J
R9	Res, Fxd, Comp	RC42GF472J
R10	Res, Var, Comp	RV4LAYS103A
R11	Res, Fxd, Comp	RC42GF103J
R12	Res, Fxd, Comp	RC32GF122J
R13	Res, Fxd, Comp	RC32GF152J
R14	Same as R12	
R15	Same as R13	
XK1	Soc, Rel	TS171-4
XK2	Same as XK1	

TLAA-1K RF Linear Power Amplifier

REF SYMBOL	DESCRIPTION	TMC PART NUMBER
A1001	Printed Circuit Board Assembly	A-4879*
A1002	Tune Capacitor Assembly	AX5132*
A1003	Load Capacitor Assembly	AX5133*
A1004	Printed Circuit Board Assembly	A-4878*
A1005	Printed Circuit Board Assembly	A-4850-2*
A1006	Bandswitch Assembly	AS160*
A1007	Printed Circuit Board Assembly	A-4807-2*
C1001 thru C1004	Capacitor, Fxd, Polyester	CX119-104M
C1005	Capacitor, Fxd, Cer	CC109-1
C1006	Capacitor, Fxd, Mica	CM15B300J03
DC1001	Coupler, Directional	DC108
DS1001	Lamp, Incand	BI101-1819
DS1002	Same as DS1001	
J1001	Conn, Recp, ML	MS3102A-18-16P
J1002	Conn, Recp, Fml	MS3102A18-16S
J1003	Conn, Recp, ML	MS3102A32-7P
J1004	Conn, Recp, BNC	JJ172
J1005	Same as J1004	
J1006	Conn, Recp, HN	UG560*/U
J1007	Conn, Recp, ML	MS3102A32-414P
J1008	Conn, Recp, FML	JJ310-3
L1001	Coil, RF	CL138
M1001	Meter, PL	MR216-1

TLAA-1K RF Linear Power Amplifier (con't)

REF SYMBOL	DESCRIPTION	TMC PART NUMBER
M1002	Meter, Output	MR217
S1001	Switch, Lever	SW523-3
S1002	Switch, Actuator	SW347
S1003	Switch, Intlk	SW219
XA1001	Conn, Recp, PC Board	JJ319-22-DFE
XA1002	Conn, Recp, PC Board	JJ287
XA1003	Same as XA1002	
XDS1001	Lamp, Holder, Bay	TS107-2
XDS1002	Same as XDS1001	
C1101 thru C1107	Capacitor, Fxd, Cer	CK70AW202M
C1108	Capacitor, Fxd, Cer	CC108-4P-1000M
C1109	Same as C1108	
C1110 thru C1112	Capacitor, Fxd, Cer	CK70AW202M
C1113	Not used	
C1114	Not used	
C1115	Capacitor, Fxd, Cer	CC100-37
C1116	Capacitor, Fxd, Elec	CE105-25-25
C1117	Capacitor, Fxd, Elec	CE105-10-50
CR1101	Scond, Dev, Dio	1N3022B
CR1102	Scond, Dev, Dio	1N547
E1101	Not used	
E1102	Bush, Slot Heat	TE101-3



TLAA-1K RF Linear Power Amplifier (con't)

REF SYMBOL	DESCRIPTION	TMC PART NUMBER
E1103	Term, Turret	TE102-2
E1104	Bush, Slot Head	TE101-3
E1105 thru E1108	Same as E1103	
K1101	Rel, Arm, DPDT	RL156-1
R1101 thru R1103	Resistor, Fxd, Comp	RR114-5W
R1104	Resistor, Fxd, Comp	RC42GF100J
R1105	Resistor, Fxd, WW	RW111-4
R1106	Resistor, Fxd, Comp	RC42GF391J
R1107	Resistor, Fxd, Comp	RC32GF102J
R1108	Resistor, Fxd, Comp	RC20GF103J
R1109	Resistor, Var, Comp	RV106UX10C102A
R1110	Resistor, Fxd, Comp	RC20GF101J
R1111	Resistor, Fxd, WW	RW110-1
R1112	Resistor, Fxd, Comp	RC42GF102J
R1113	Resistor, Fxd, Comp	RC42GF821J
S1101	Switch, Intlk	SW219
TB1101	Terminal, Strip	TM121-1
XK1101	Socket, Relay	TS171-1
Z1101	Time, Delay	NW183-24-30
C1201	Capacitor, Fxd, Mica	CM111C181J5S
C1202	Capacitor, Fxd, Cer	CC100-16
C1203	Capacitor, Fxd, Cer	CC100-37
C1204	Capacitor, Fxd, Cer	CC100-32
C1205	Same as C1204	

TLAA-1K RF Linear Power Amplifier (con't)

REF SYMBOL	DESCRIPTION	TMC PART NUMBER
C1206	Capacitor, Fxd, Cer	CC100-31
C1207	Capacitor, Fxd, Mica	CM111E220J5S
C1208	Capacitor, Fxd, Mica	CM112F222F3S
C1209 thru C1212	Same as C1203	
C1213 C1214	Capacitor, Fxd, Cer Same as C1213	CC100-23
C1215	Capacitor, Fxd, Cer	CC109-38
C1216	Same as C1204	
C1217	Same as C1203	
C1218	Same as C1215	
C1219	Capacitor, Fxd, Paper	CP41B1EF405K
C1220	Same as C1203	
E1201 thru E1208	Term, Turret	TE102-2
L1201	Not used	
L1202	Coil, RF	CL101-2
L1203 thru L1205	Coil, RF	CL140-2
L1206	Ind, Fxd	CL459
L1207	Coil, RF	CL178
R1201	Resistor, Fxd, Comp	RC20GF102J
R1202	Resistor, Fxd, Comp	RC32GF100J
R1203	Resistor, Fxd, Comp	RC42GF120J
R1204	Resistor, Fxd, Comp	RC42GF222J

TLAA-1K RF Linear Power Amplifier (con't)

REF SYMBOL	DESCRIPTION	TMC PART NUMBER
R1205	Resistor, Fxd, Comp	RC20GF333J
R1206	Resistor, Fxd, Comp	RC42GF331J
R1207	Resistor, Fxd, Comp	RC42GF472J
R1208	Resistor, Fxd, Comp	RR114-20W
R1209	Resistor, Fxd, Comp	RC20GF102J
R1210	Same as R1209	
R1211	Resistor, Fxd, Comp	RC42GF183J
R1212	Resistor, Fxd, Comp	RC42GF154J
R1213	Same as R1212	
R1214	Resistor, Fxd, WW 10W	RW109-28
T1201	Coil, RF, Adj	CL460
V1201	Tube, E1	8233
V1202	Tube, E1	4CX350A
XV1201	Socket, E1 Tube	TS198
XV1202	Socket, E1 Tube	TS197
Z1201	Supp, Parasitic	A1546-2
Z1202	Supp, Parasitic	A1546-4
B1301	Blower, Cent	BL134
C1301	Capacitor, Fxd, Mica	CM112F562J5S
C1302	Capacitor, Fxd, Cer	CC100-37
C1303	Not Used	
C1304	Capacitor, Var	CV11D450
C1305	Same as C1302	
C1306	Capacitor, Fxd, Mica	CM111C121J5S
C1307	Capacitor, Fxd, Cer	CC100-32
C1308	Same as C1307	
C1309	Same as C1302	
C1310	Capacitor, Fxd, Cer	CC109-38

TLAA-1K RF Linear Power Amplifier (con't)

REF SYMBOL	DESCRIPTION	TMC PART NUMBER
C1311 thru C1315	Capacitor, Fxd, Cer	CC109-36
C1316	Capacitor, Fxd, Cer	CC108-4P1000M
C1317 thru C1321	Capacitor, Fxd, Cer	CC109-6
C1322	Same as C1310	
C1323	Same as C1310	
E1301	Term, Turret	TE102-2
E1302	Ins, Standoff	NS3W0108
K1301	Relay, Arm	RL185
K1302	Same as K1301	
L1301	Coil, Output	CL463
L1302	Coil, RF	CL140-6
L1303	Same as L1302	
L1304	Coil, RF	CL471
R1301	Resistor, Fxd, Comp	RR116-1400W
R1302	Resistor, Fxd, Comp	RR114-5W
R1303	Same as R1301	
S1301	Switch, Micro	SW252
T1301	Transformer, Match	TR195
TB1301	Term, Strip, Barr	TM102-6
V1301	Tube, E1	8576/PL264J
XV1301	Socket, E1, Tube	TS182

A-4879 Printed Circuit Board Assembly

REF SYMBOL	DESCRIPTION	TMC PART NUMBER
C1 thru C17	Capacitor, Fixed, Polyester	CX119-104M
C18	Not used	
C19 thru C21	Same as C1	
C22	Capacitor, Fixed, Mica	CM111C200J5S
C23	Capacitor, Fixed, Mica	CM111E511H5S
C24	Capacitor, Fixed, Elec	CE105-3-25
C25	Same as C1	
C26	Capacitor, Fxd, Elec	CE105-20-15
C27 C28, C29, C30 CR1	Capacitor, Fxd, Elec <b>CAPACITOR, FXD,</b> Scond, Dev, Dio	CE105-50-15 <b>CC139-39</b> 1N759
CR2	Same as CR1	
CR3 thru CR5	Scond, Dev, Dio	1N2484
CR6 thru CR8	Scond, Dev, Dio	1N645
CR9	Not used	
CR10	Not Used	
CR11	Same as CR3	
L1	Coil, RF	CL240-120
L2	Same as L1	
Q1	Transistor	2N492A
Q2	Transistor	2N1595

A-4879 Printed Circuit Board Assembly (con't)

REF SYMBOL	DESCRIPTION	TMC PART NUMBER
Q3	Same as Q2	
R1	Resistor, Var, Comp	RV111U502A
R2	Resistor, Var, Comp	RV111U103A
R3	Resistor, Fixed, Comp	RC20GF152J
R4	Resistor, Fixed, Comp	RC20GF102J
R5	Resistor, Fixed, Comp	RC20GF153J
R6	Resistor, Fixed, Comp	RC20GF391J
R7	Same as R6	
R8	Same as R4	
R9	Resistor, Fixed, Comp	RC20GF821J
R10	Resistor, Fixed, Comp	RC20GF121J
R11	Resistor, Fixed, Comp	RC20GF122J
R12	Resistor, Fixed, Comp	RC20GF102J
R13	Resistor, Fixed, Comp	RC20GF222J
R14	Resistor, Fixed, Comp	*
R15	Resistor, Fixed, Comp	*
R16	Resistor, Fixed, Comp	*
R17	Not Used	
R18	Not Used	
R19	Not Used	
R20	Resistor, Fixed, Comp	RC20GF224J
R21	Resistor, Fixed, Comp	RC20GF474J
R22	Resistor, Fixed, Comp	RC07GF562J
Z1	Network, OP Amp	NW156

\* Nominal Value. Actual value to be selected by factory calibration

AX5132 Capacitor Tune Assembly

REF SYMBOL	DESCRIPTION	TMC PART NUMBER
A1002A1	Board, Assembly, PC	A-4790
A1002B1	Motor Servo	M0127
A1002C1	Capacitor, Var, Vac	CB177
A1002S1	Switch, SPDT	SW353-1
A1002S2	Same as A1002S1	
	A-4790 Board, Assembly, PC p/o AX5132	
C1 thru C4	Capacitor, Fixed, Cer	CC100-16
C5	Capacitor, Fixed, Paper	CN114-1R0-4J
C6 thru C13	Capacitor, Fixed, Cer	CC100-16
E1 thru E12	Term, Stud	TE127-3

AX5133 Load Capacitor Assembly

REF SYMBOL	DESCRIPTION	TMC PART NUMBER
A1003A1	Board, PC Assembly	A-4790
A1003B1	Motor	MO127
A1003C1	Capacitor, Variable, Air	CB175
A1003S1	Switch	SW353-2
A1003S2	Same as A1003S1	



A-4878 Printed Circuit Board Assembly

REF SYMBOL	DESCRIPTION	TMC PART NUMBER
C1 thru C9	Capacitor, Fxd, Polyester	CX119-104M
CR1 thru CR9	Scond, Dev, Dio	1N645
DS1 thru DS9	Lamp, Incand	BI114-2
E1 thru E10	Terminal, Stud	TE127-2
R1	Resistor, Fxd, Comp	RC32GF391J

A-4850-2 Printed Circuit Board Assembly

REF SYMBOL	DESCRIPTION	TMC PART NUMBER
C1	Capacitor, Fixed, Cer	CC100-28
C2	Same as C1	
C3	Capacitor, Fixed, Elec	CE107-6
CR1	Scond, Dev, Dio	1N34A
E1 thru E3	Terminal, Stud	TE127-2
R1	Resistor, Fixed, Comp	RC20GF272J
R2	Resistor, Fixed, Comp	RC20GF102J

## AS160 Band Switch Assembly

REF SYMBOL	DESCRIPTION	TMC PART NUMBER
C1 thru C6	Capacitor, Fixed, Cer	CC109-38
C7	Capacitor, Fixed, Cer	CC109-28
C8	Capacitor, Fixed, Cer	CC109-19
CR1	Scnd, Dev, Dio	1N547
E1	Term, Turret	TE102-2
E2	Same as E1	
K1	Rel, Arm, DPDT	RL168-2C10-24DC
L1	Coil, Rf	CL292
L2	Coil, MN, Tank	CL470
L3	Coil. Load	CL472
P1	Conn, PL, ML, 37/C	JJ313-3H
S1A	Assembly, Bnd, Bd	BMA464
S1B	Assembly, Output, Bd	BMA465
S2	Switch, Rotary, Solenoid	SW429
XK1	Socket, Relay	TS100-3

A-4807-2 Printed Circuit Board Assembly

REF SYMBOL	DESCRIPTION	TMC PART NUMBER
C1 thru C5	Capacitor, Fixed, Cer	CC100-16
CR1 thru CR3	Scond, Dev, Dio	1N3070
CR4	Scond, Dev, Dio	1N3022B
L1	Transformer, Fixed	TR194
R1	Resistor, Fixed, Comp	RC20GF102J
R2	Resistor, Fixed, Comp	RC42GF470J
R3	Same as R2	
R4	Same as R1	
R5	Same as R1	
R6	Resistor, Fixed, Comp	RC20GF222J
R7	Same as R1	
R8	Resistor, Variable	RV111U252A

SECTION 7  
MAINTENANCE DIAGRAMS

7-1. GENERAL

This section contains the following maintenance diagrams for HFLA-1K:

Figure

- |     |  |
|-----|--|
| 7-1 | Low Voltage and Bias Supply AP151<br>Schematic Diagram - CK1870  |
| 7-2 | High Voltage Power Supply AP152<br>Schematic Diagram - CK1869    |
| 7-3 | Power Amplifier TLAA-1K<br>Schematic Diagram - CK1873 (3 sheets) |
| 7-4 | Servo Control AX5130<br>Schematic Diagram - CK1883 (4 sheets)    |

D

C

B

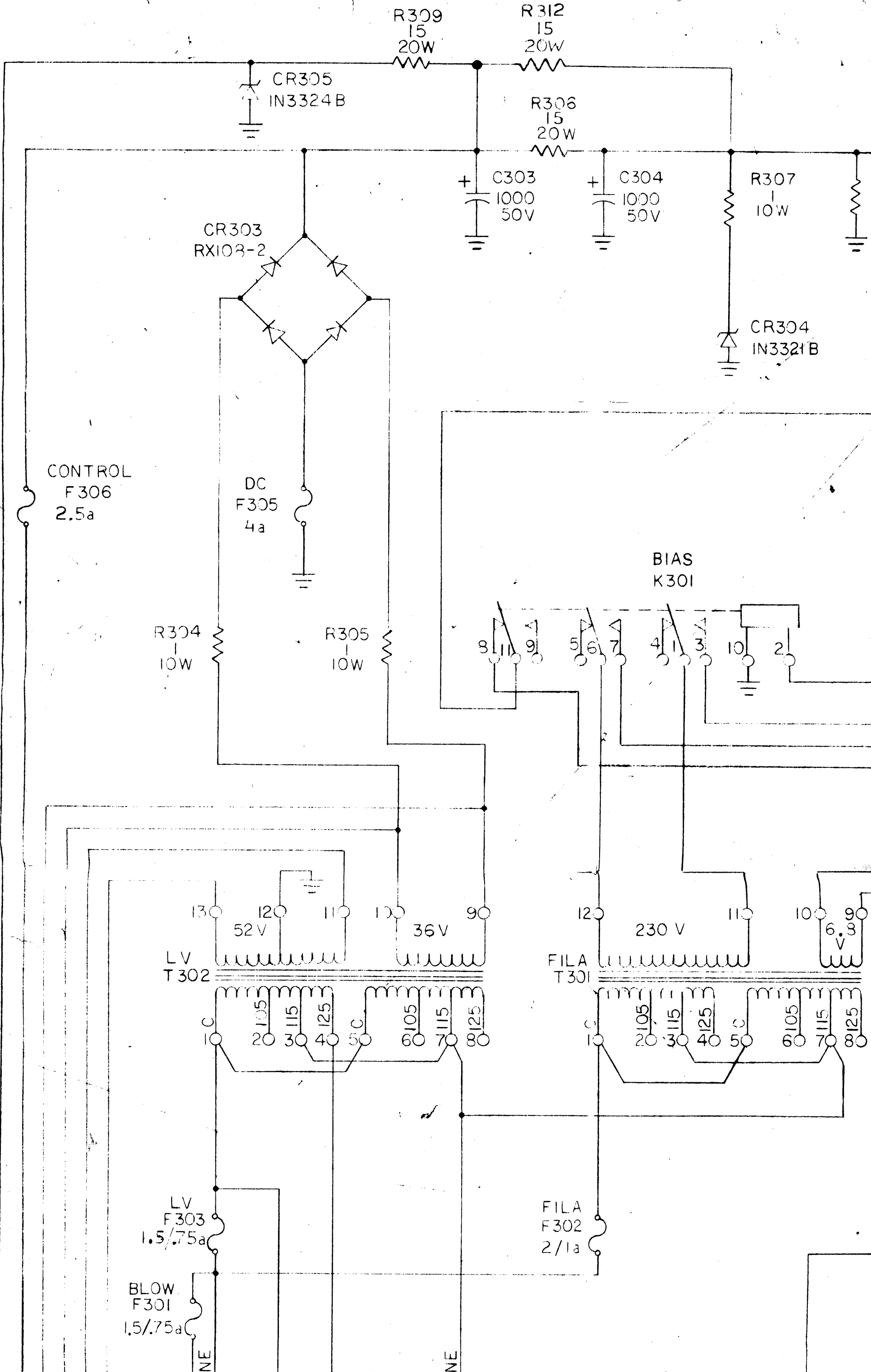

CONTROL  
F306  
2.5a

DC  
F305  
4a

BIAS  
K301

R304  
10W

R305  
10W

LV  
T302

FILA  
T301

LV  
F303  
1.5/75a

BLOW  
F301  
1.5/75a

FILA  
F302  
2/1a

LINE

LINE

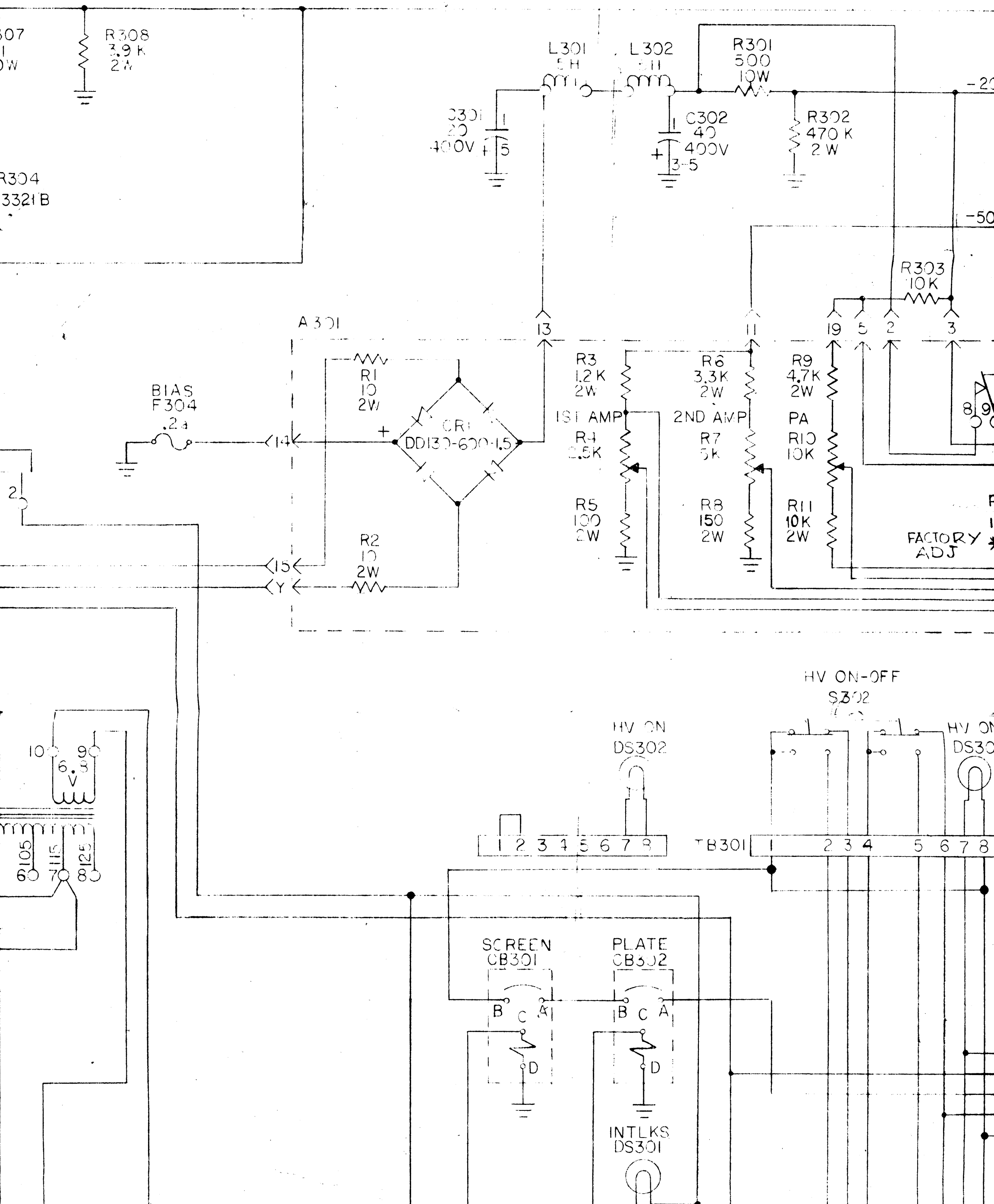

					REVISIONS		
E.M.N.NO	DRAFT	CHKD	ZONE	LTR	DESCRIPTION	DATE	APPROV
	(1)			B			
	(2)			A	ADDED 11	1/14/71	
2152				E	REVISIONS TO 11/14/71	1/21/71	
2152	VE			C	ADDED 11	2/7/72	
				D	ADDED 11	4/13/72	
				E	R16 WITH NOTE ADDED	6/14/75	
21932	XAO			F	R11 10K WAS 12K	3-29-82	

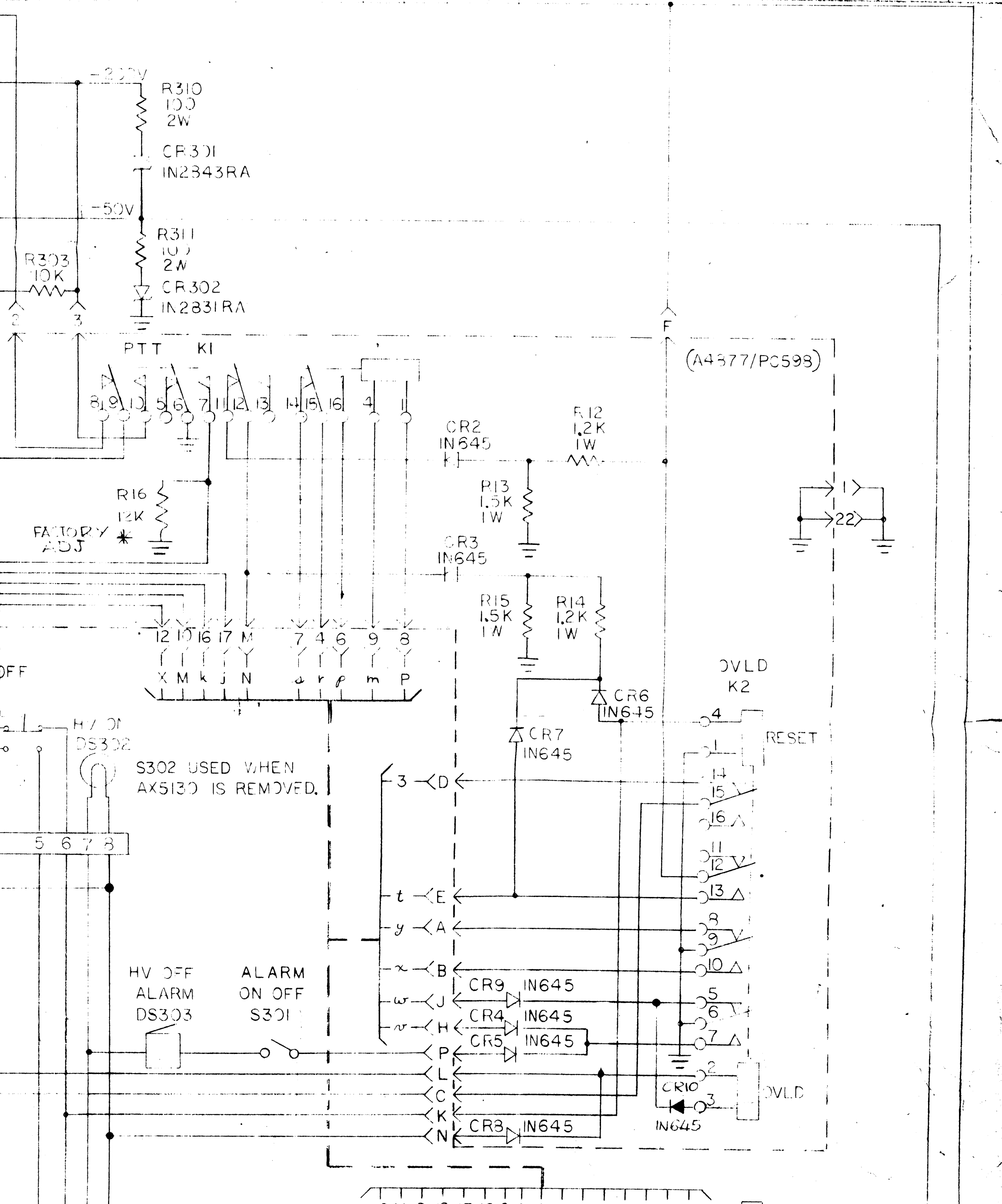



REVISIONS						DATE	APPROVED
E.M.N.NO	DRAFT	CHKD	ZONE	LTR	DESCRIPTION		
	(1)			B		1/11/82	
	(2)			A	ADDED R11	1/11/82	
21523				E	REMOVED R11 AND R12	1/11/82	
21523				C	ADDED R13	2/7/82	
				D	ADDED R14	4/13/82	
				E	R15 AND R16 ADDED	5/19/82	
21532				F	R11 10K WAS 12K	3-29-82	

R310  
100  
2W

CR301  
IN2843RA

R311  
100  
2W  
CR302  
IN2831RA

TT KI

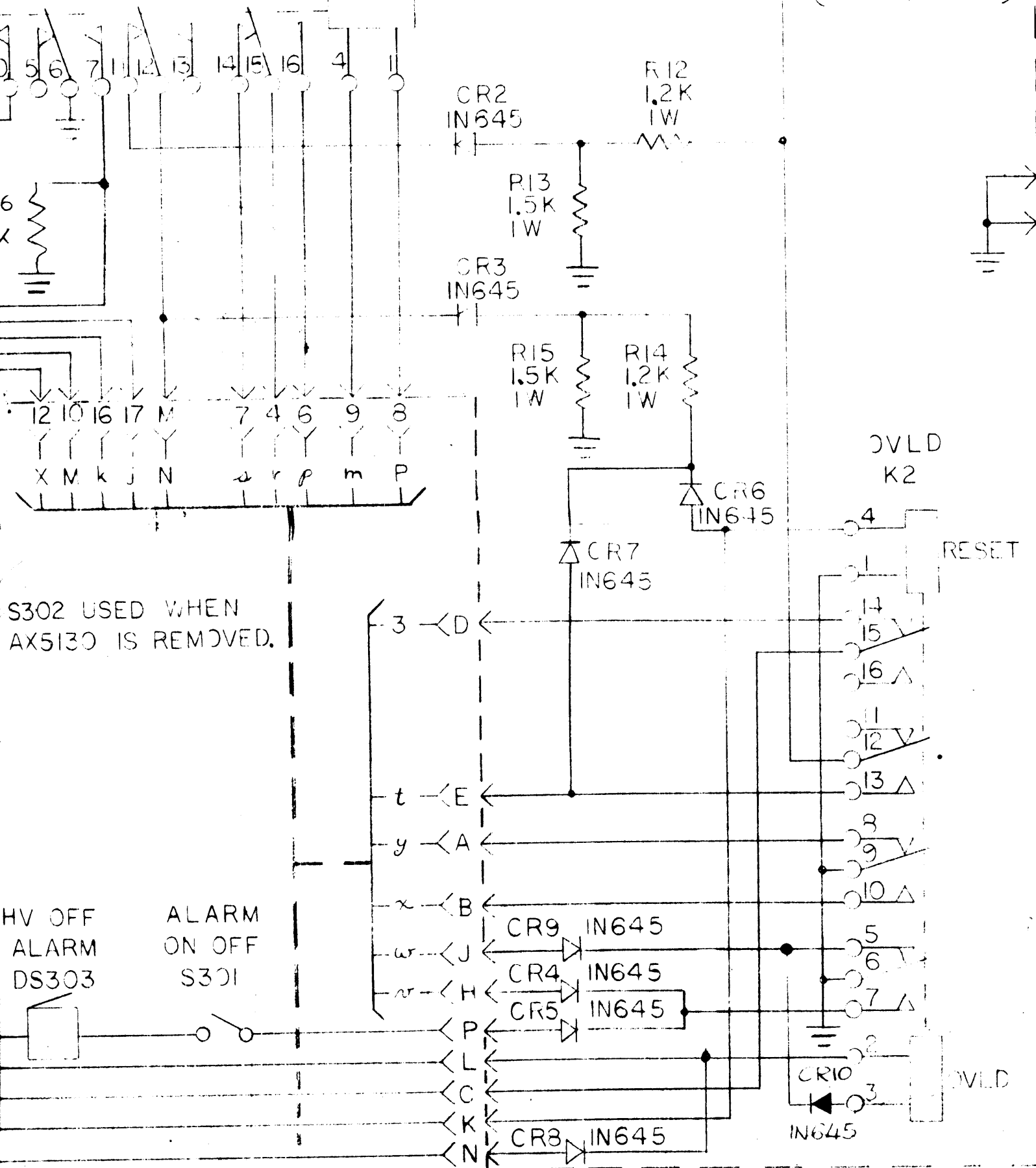

D

C

B OK 18701 E

C

B

A

CONTROL  
F306  
2.5a

DC  
F305  
4a

BIAS  
K301

R304  
10W

R305  
10W

LV  
T302

FILA  
T301

LV  
F303  
1.5/.75a

BLOW.  
F301  
1.5/.75a

FILA  
F302  
2/1a

LINE

LINE

J301

4 K L H J

Y E

T S

h

z a b c d e

LAST SYMBOLS

300 SERIES

A301 SERIES

A301 S302  
 C304 T302  
 CB302 TB301  
 CR305 XC302  
 DS303 XCR302  
 F306 XDS302  
 J301 XF306  
 K301 XK301  
 L302 XA301

MISSING SYMBOLS

R312

UNLESS OTHERWISE SPECIFIED:

1. ALL RESISTANCES ARE IN OHMS,  $\frac{1}{2}$  W.
2. ALL CAPACITANCES ARE IN MFD.
3. ALL INDUCTANCES ARE IN H.
4. AC FUSE VALUES SHOWN FOR 115/230 V
5. TRANSFORMERS SHOWN WIRED FOR 115 V  
JUMPERS TO CORRESPOND.
6. PARTIAL REFERENCE DESIGNATIONS ARE  
THE PART DESIGNATION WITH THE SUB

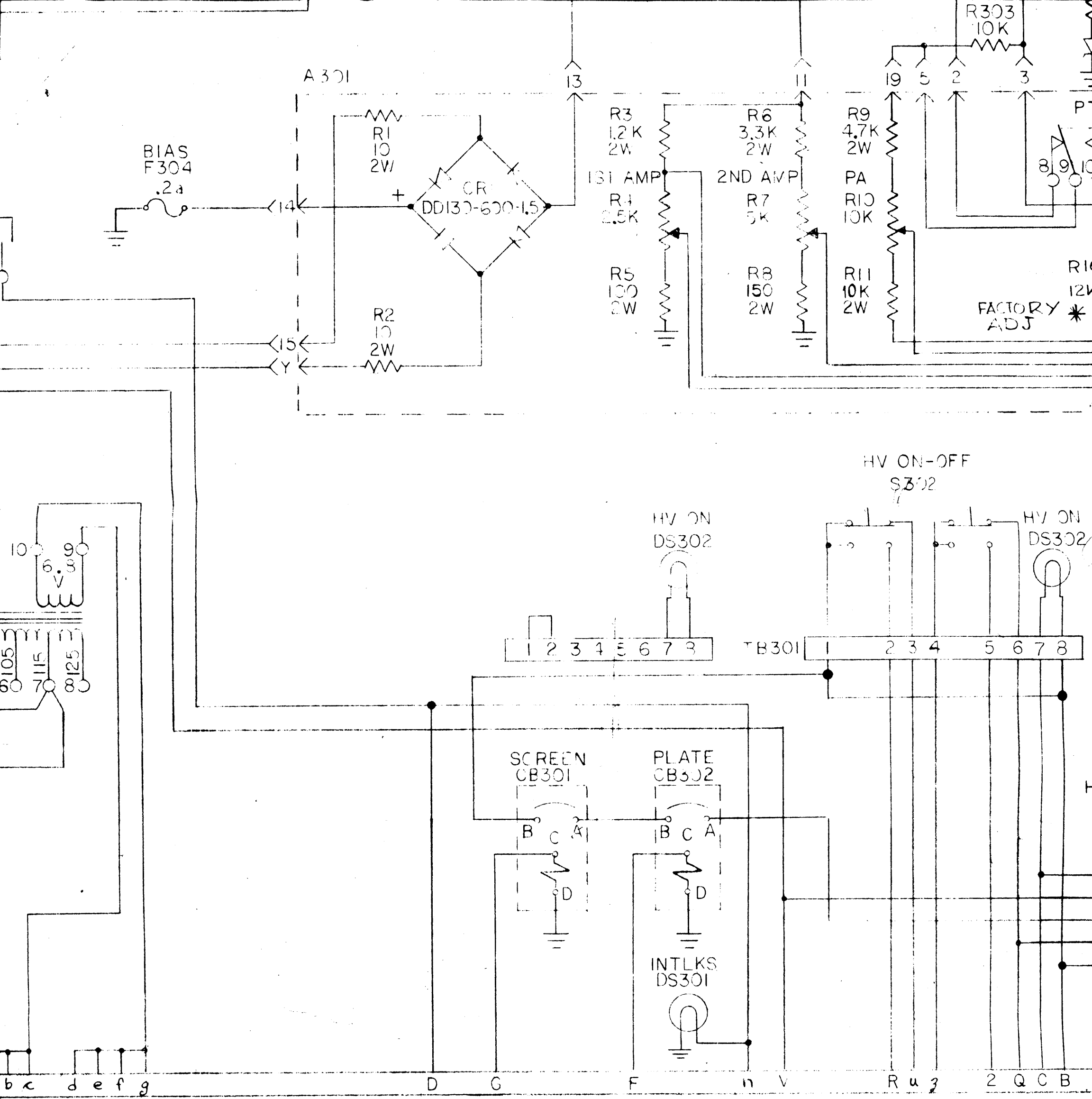

1/2 W.  
D.

1115/230 V OPERATION.  
FOR 115 V. FOR OTHER VOLTAGES CHANGE LINE #

CONDITIONS ARE SHOWN. FOR COMPLETE DESIGNATION PREFIX  
THE SUB-ASSEMBLY DESIGNATION.

1	HFLA-1K	AP151
QTY / UNIT	MODEL USED ON	ASS'Y NO.
<b>APPLICATION</b>		
	CODE	
<p><b>NOTICE TO PERSONS RECEIVING THIS DRAWING</b>          THE TECHNICAL MATERIEL CORPORATION claims proprietary right in the material disclosed hereon. This drawing is issued in confidence for engineering information only and may not be reproduced or used to manufacture anything shown hereon without permission from THE TECHNICAL MATERIEL CORPORATION to the user. This drawing is loaned for mutual assistance and is subject to recall at any time.</p>		

5

4

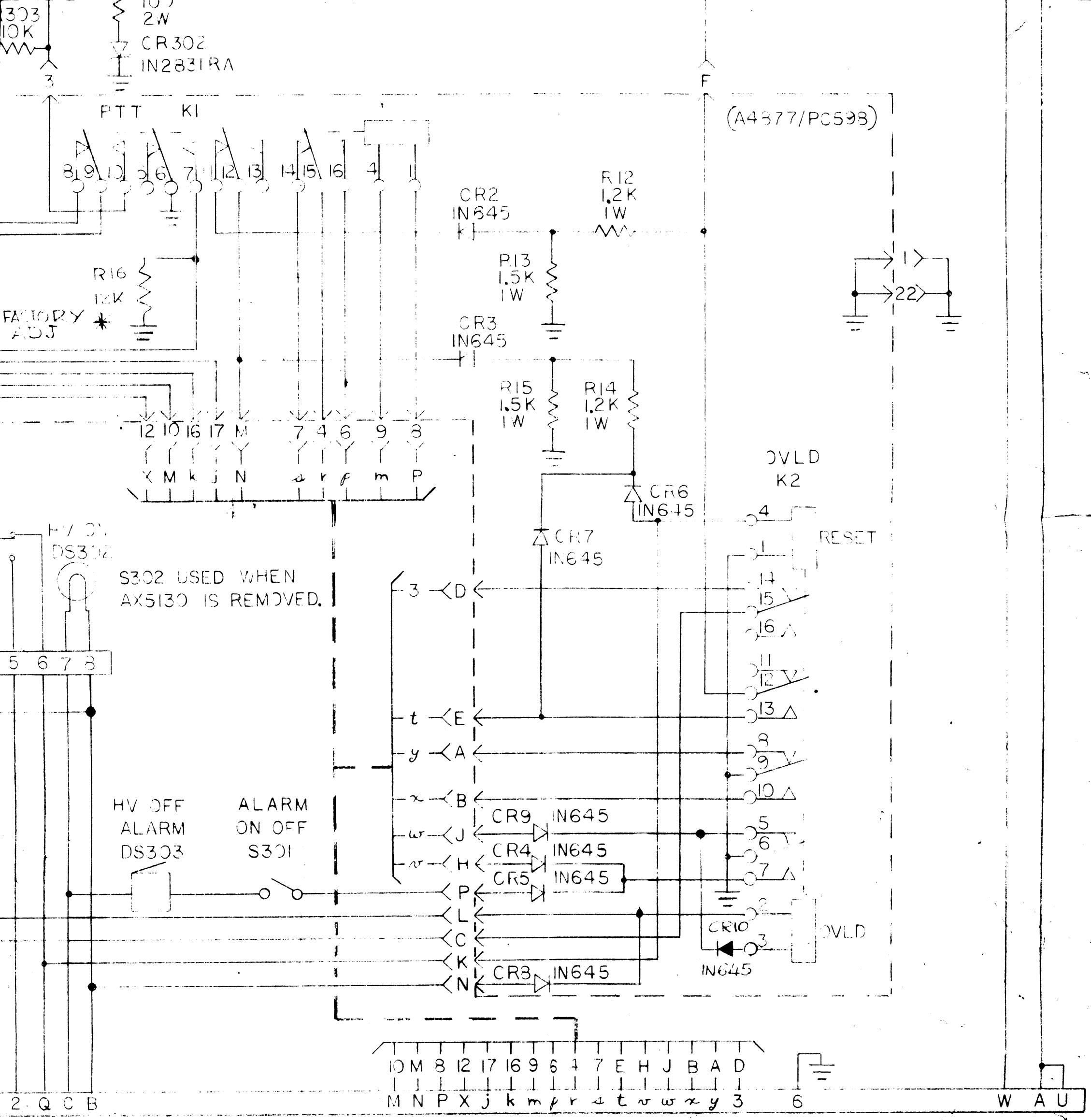

UNLESS OTHERWISE SPECIFIED  
DIMENSIONS ARE IN INCHES  
AND INCLUDE CHEMICALLY APPLIED  
OR PLATED FINISHES

TOLERANCES ON

DECIMALS	FRACTIONS
.X ± .05	± 1/64"
.XX ± .01	ANGLES
.XXX ± .005	± 0° -30'

MATERIAL

FINISH

Schematic Diagram,  
Low Voltage and Bias Supply AP151

7-3/7-4

Not disclosed hereon.  
reproduced or used  
without permission of  
GENERAL CORPORATION  
any time.

3

2

1

2W  
CR302  
IN2831RA

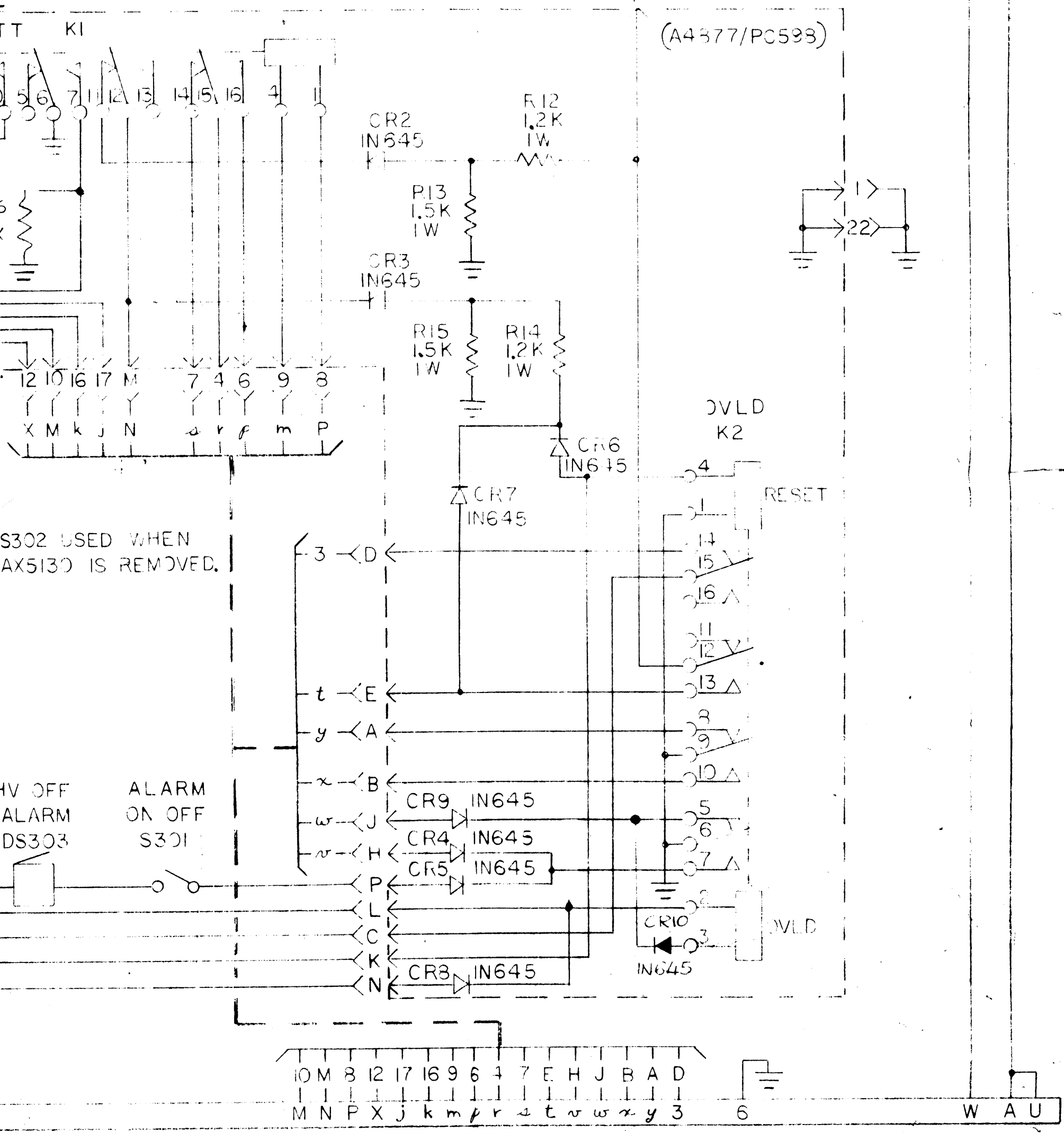

UNLESS OTHERWISE SPECIFIED DIMENSIONS ARE IN INCHES AND INCLUDE CHEMICALLY APPLIED OR PLATED FINISHES	
TOLERANCES ON	
DECIMALS	FRACTIONS
.X ± .05	± 1/64
.XX ± .01	ANGLES
.XXX ± .005	± 0°-30'
MATERIAL	
FINISH	

Schematic Diagram,  
Low Voltage and Bias Supply AP151

7-3/7-4

C

B  
OK 1870

A

3 2 1

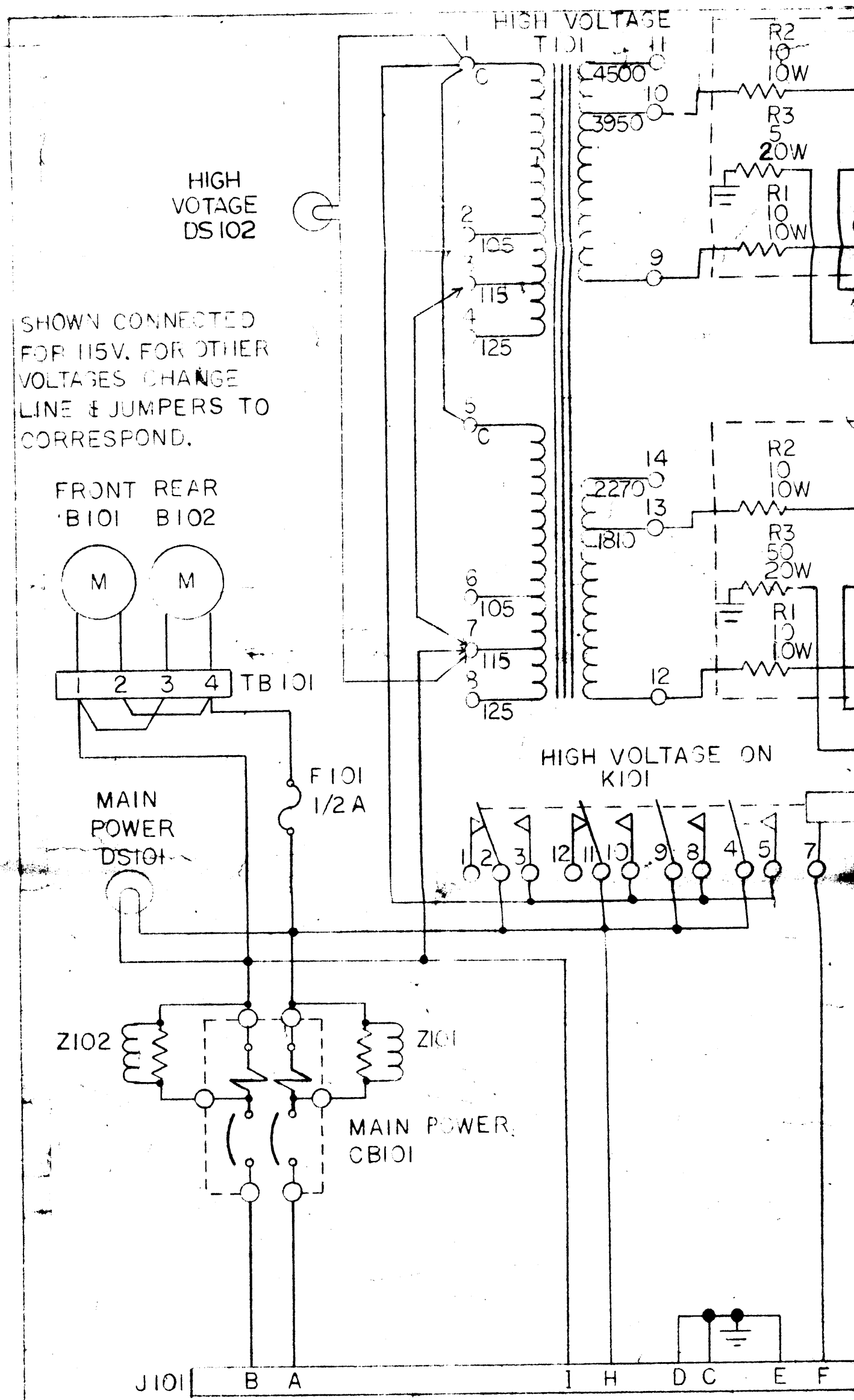

SHOWN CONNECTED  
 FOR 115V. FOR OTHER  
 VOLTAGES CHANGE  
 LINE & JUMPERS TO  
 CORRESPOND.

MISSING SYMBOLS

A100	A101	A102	A103
------	------	------	------

LAST SYMBOLS

100	A101	A102	A103
-----	------	------	------

PARTIAL REFERENCE DESIGN  
 FOR COMPLETE DESIGNATION  
 DESIGNATION WITH THE AS

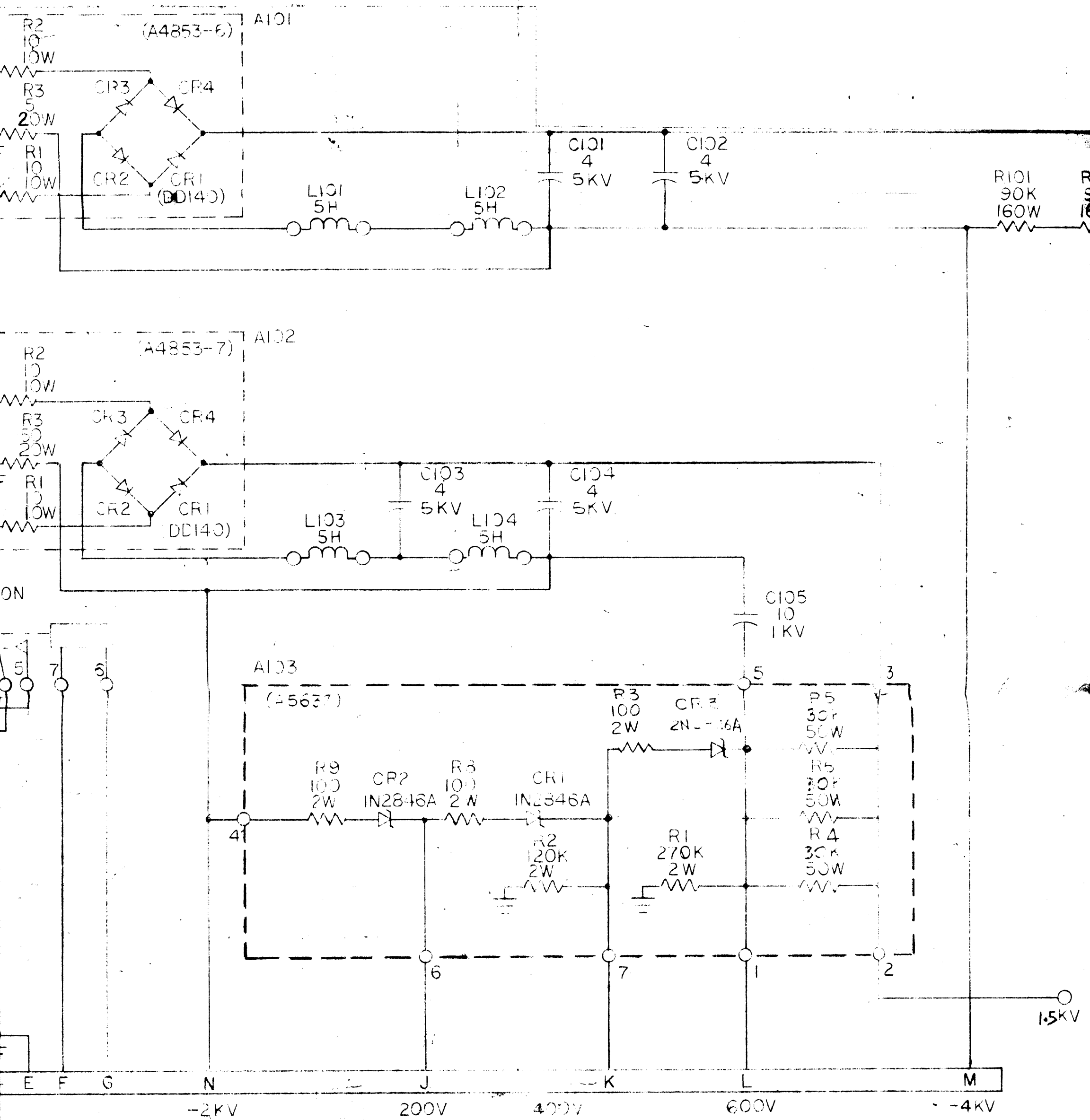

					REVISIONS		
E.M.N.NO	DRAFT	CHKD	ZONE	LTR	DESCRIPTION	DATE	APP
20625	GE	8		C	ADDED HV. TAP ON DS 2 (TO HVA)	4-15-72	
20822				D	REVISION TO REVISION 11-26-73	11-26-73	
21405				F	REVISION TO REVISION 11-26-73	11-26-73	
21405				F	A5637 WAS 21575 R2 WAS 07E 200E R3 WAS 20W CR3 ADEF	5-21-75	
21405	WJB	M		G	VAL 4-12 FOR R6 AND R7	2-21-78	
21651	SDL			H	CI01 - 104 WAS 4KV	3-16-78	
21730				J	R1 WAS 15KV, 600V WAS 300, 1.5K / WAS 2KV	3-23-82	
21903				K	R5 and R6 30K WAS 15K	1-11-83	

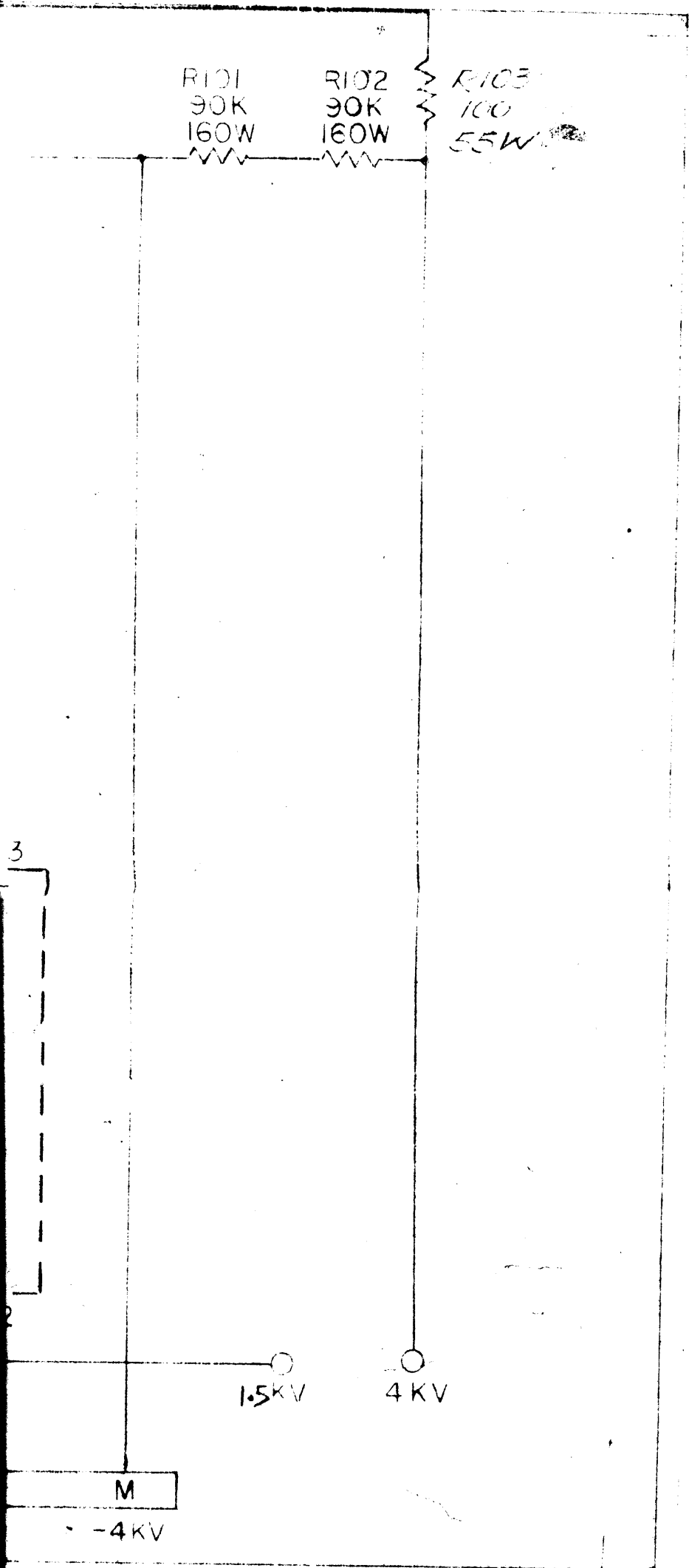



					REVISIONS		
E.M.N.NO	DRAFT	CHKD	ZONE	LTR	DESCRIPTION	DATE	APPROVED
21625	GE	8		C	1.5K/1.5KV WAS 1.5K/1.5KV	4-10-72	8
21627				D	R5 and R6 30K WAS 15K	11-1-72	
21628				E	1.5K/1.5KV WAS 1.5K/1.5KV	11-28-72	
21405				F	A3637 WAS 1.5-75 52.45 87.3 2.05 R5 WAS 30K CR3 ADDED	5-21-75	
21629	WJB			G	VALV 1.5KV 1.5KV 1.5KV	2-21-78	*
21671	DC			H	C101 - 104 4KV	6-16-78	FB
21930				J	R4 WAS 15K/1.600V WAS 30K/1.5KV WAS 2KV	3-23-82	
21993				K	R5 and R6 30K WAS 15K	1-11-83	

D

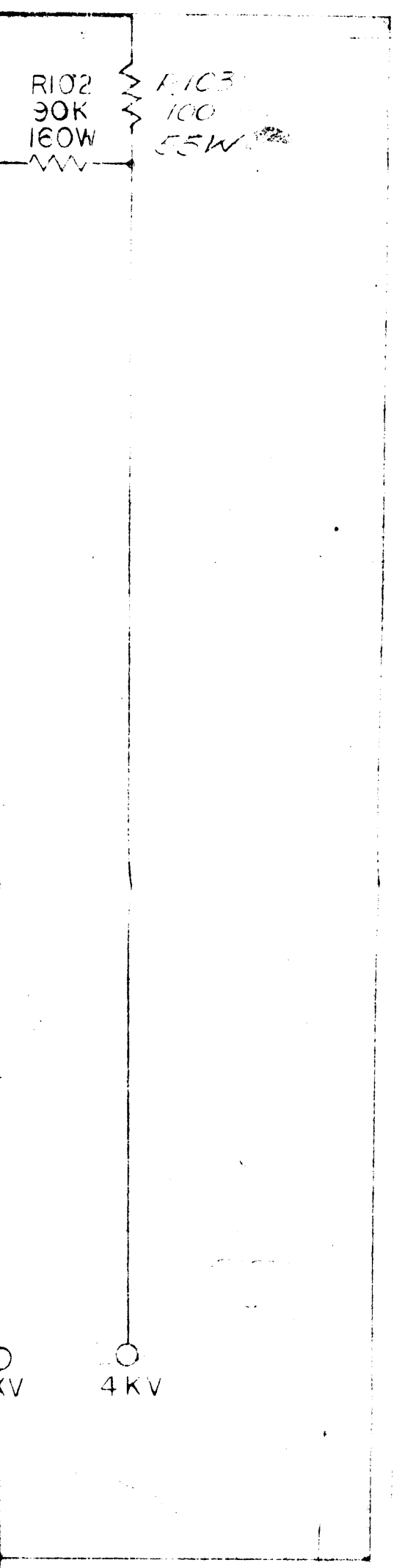

C

B

CK-1869

K

SHOWN CONNECTED FOR 115V. FOR OTHER VOLTAGES CHANGE LINE & JUMPERS TO CORRESPOND.

FRONT REAR  
B101 B102

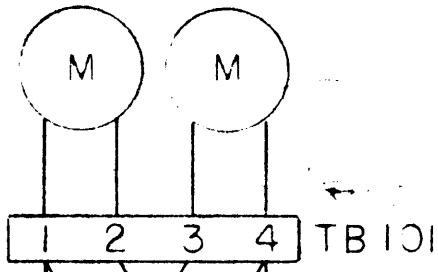

MAIN POWER  
DST101

F101  
1/2 A

HIGH VOLTAGE ON  
K101

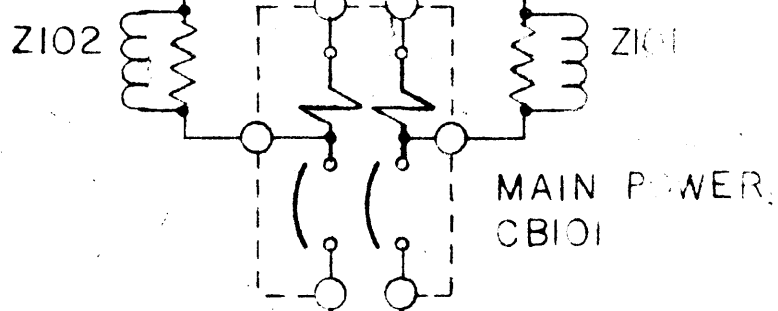

J101

B A

I

H

D

C

E

F

MISSING SYMBOLS			
A100	A101	A102	A103
			R7

LAST SYMBOLS			
100	A101	A102	A103
A103	CR4	CR4	CR3
B102	R3	R3	ER
C105			R9
F101	CB101 J101		
K101	DS102 TB101		
L104	XDS102		
R103	Z102		
T101			
XF101			
XK101			

PARTIAL REFERENCE DES  
FOR COMPLETE DESIGNAT  
DESIGNATION WITH THE AS

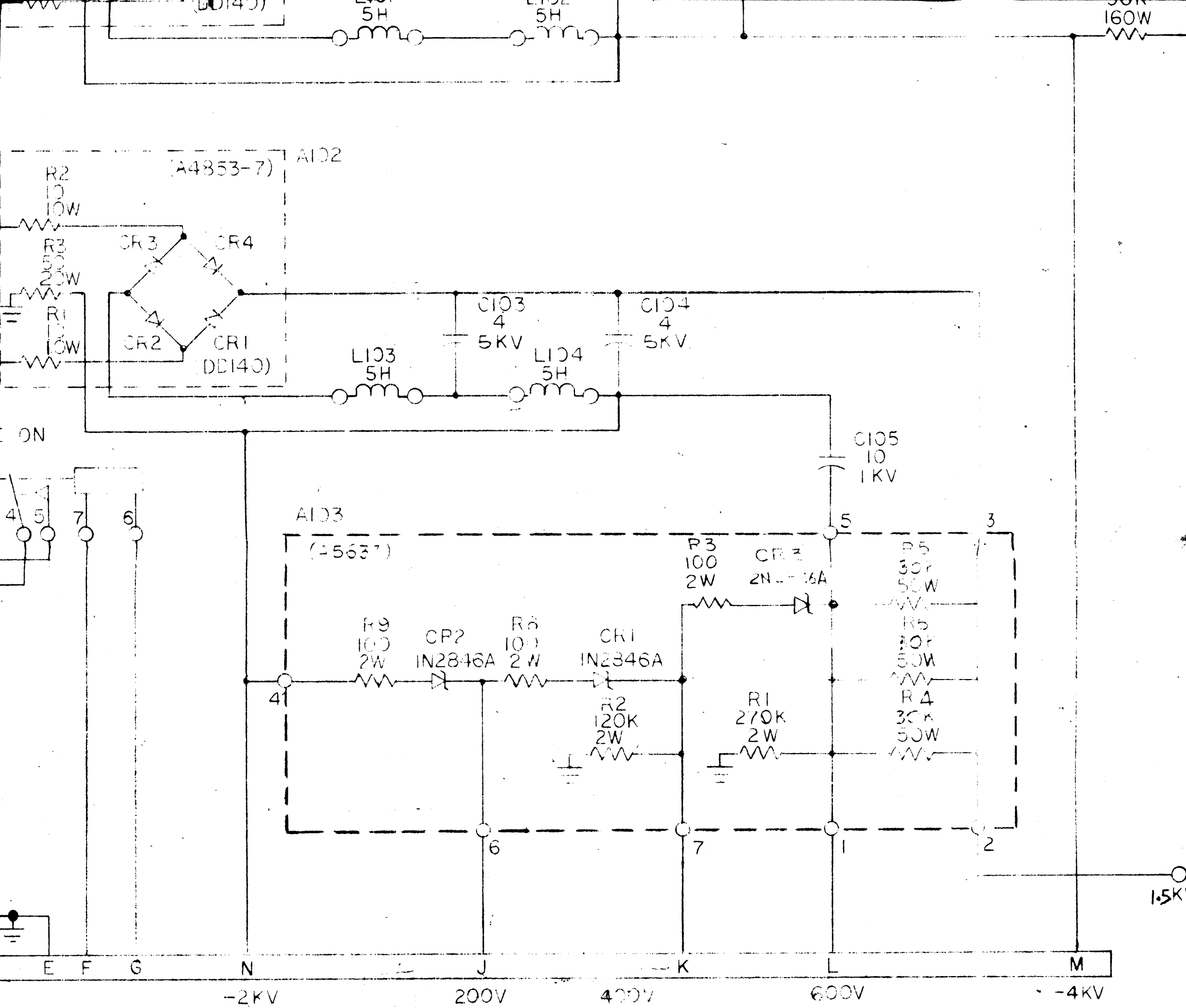

REFERENCE DESIGNATIONS ARE SHOWN.  
 DESIGNATION, PREFIX THE PART  
 WITH THE ASSEMBLY DESIGNATION.

1	HFLA-1K	AP152
QTY / UNIT	MODEL USED ON	ASS'Y NO.
APPLICATION		
CODE		

**NOTICE TO PERSONS RECEIVING THIS DRAWING**  
 THE TECHNICAL MATERIEL CORPORATION claims proprietary right in the material disclosed hereon. This drawing is issued in confidence for engineering information only and may not be reproduced or used to manufacture anything shown hereon without permission from THE TECHNICAL MATERIEL CORPORATION to the user. This drawing is loaned for mutual assistance and is subject to recall at any time.

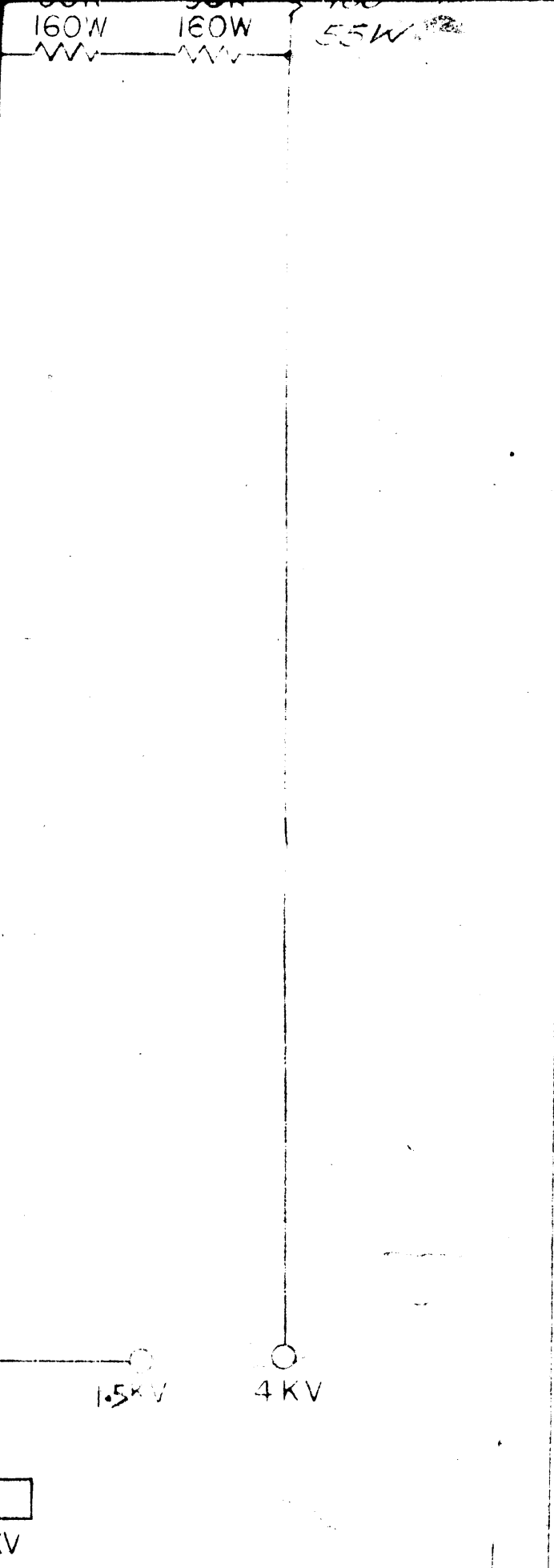

C  
B  
CK 1869  
K

UNLESS OTHERWISE SPECIFIED DIMENSIONS ARE IN INCHES AND INCLUDE CHEMICALLY APPLIED OR PLATED FINISHES	
TOLERANCES ON	
DECIMALS	FRACTIONS
.X ± .05	± 1/64
.XX ± .01	ANGLES
.XXX ± .005	± 0° -30'
MATERIAL	
FINISH	

Schematic Diagram,  
High Voltage Power Supply AP152  
7-5/7-6

A

NO.  
MATERIAL

3

2

1

50K 160W  
55W

1.5KV  
1KV

C

B  
CK1869  
K

A

UNLESS OTHERWISE SPECIFIED  
DIMENSIONS ARE IN INCHES  
AND INCLUDE CHEMICALLY APPLIED  
OR PLATED FINISHES

TOLERANCES ON

DECIMALS  
X ± .05  
.XX ± .01  
.XXX ± .005

FRACTIONS  
± 1/64  
ANGLES  
± 0° -30'

MATERIAL

FINISH

Schematic Diagram,  
High Voltage Power Supply AP152

7-5/7-6

3

2

1

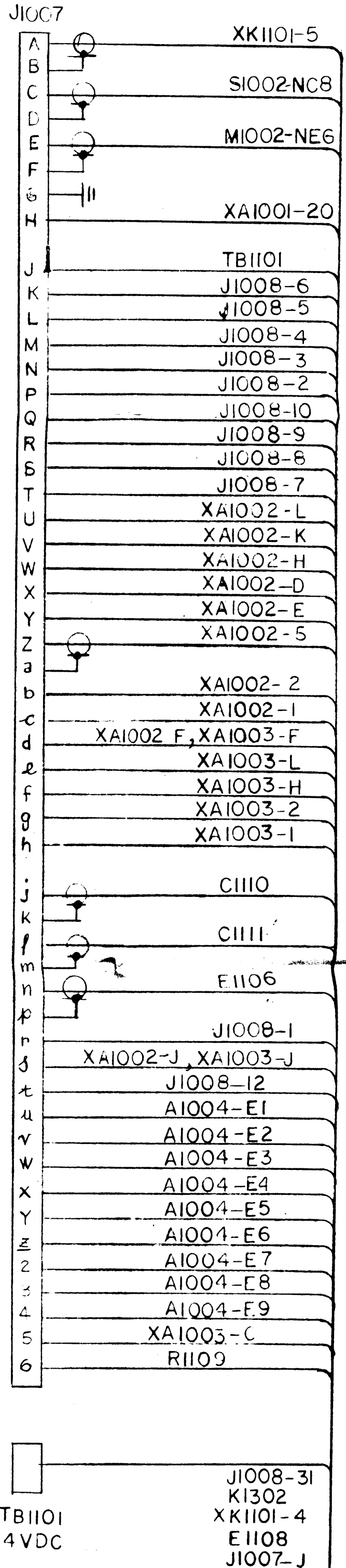
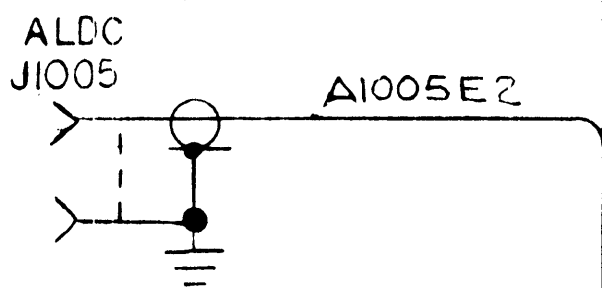
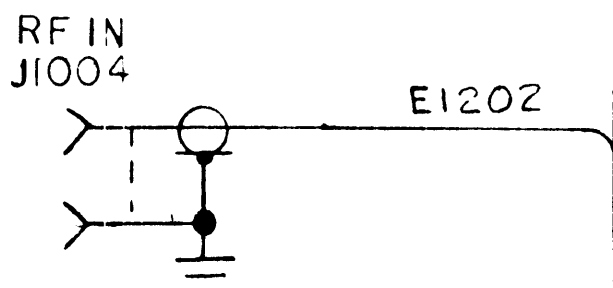
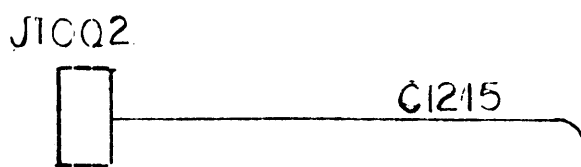
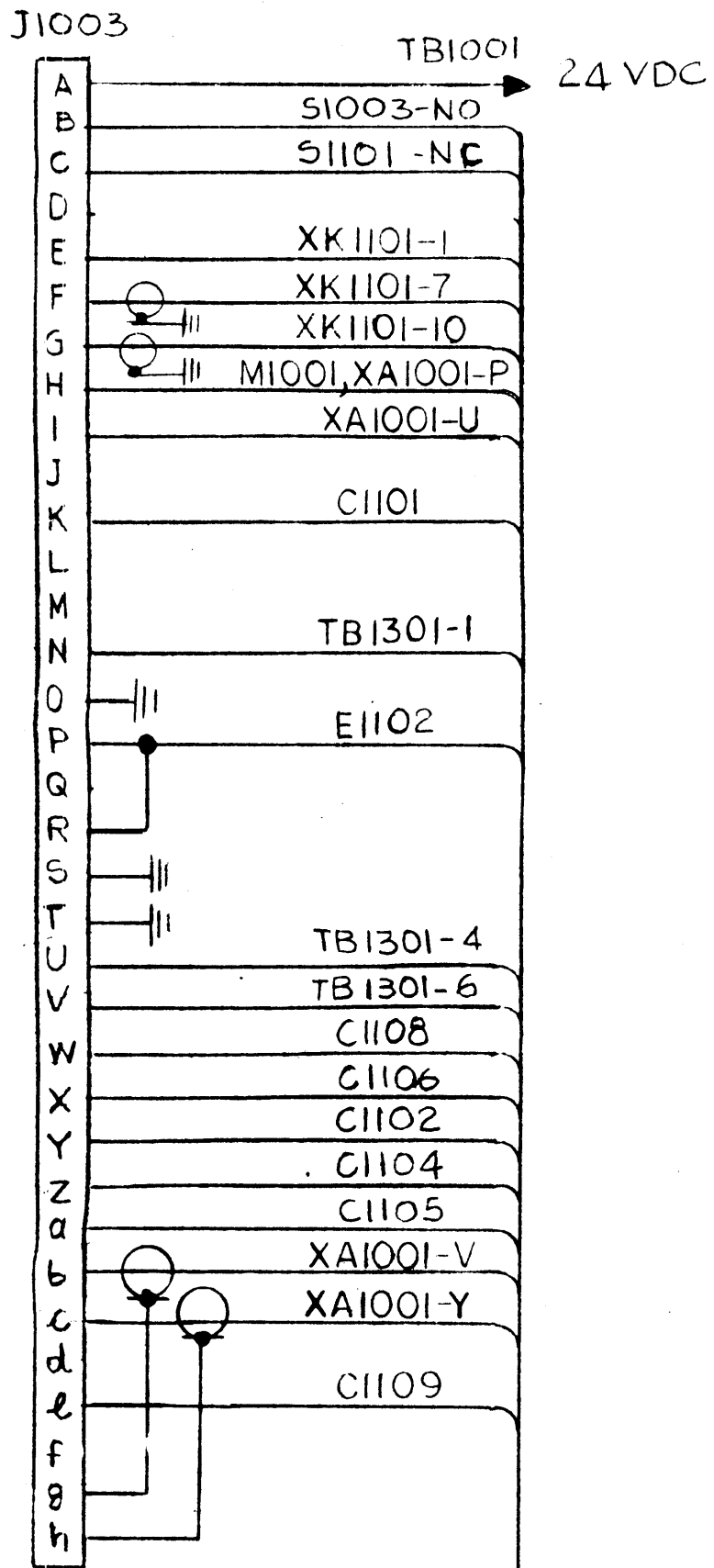

115VAC CONNECTION

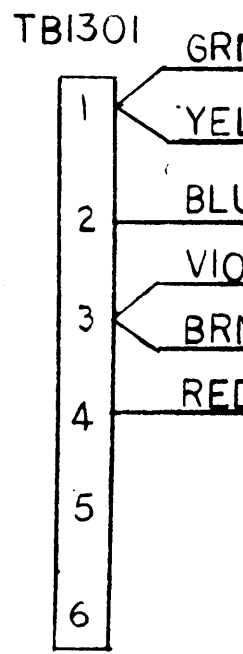
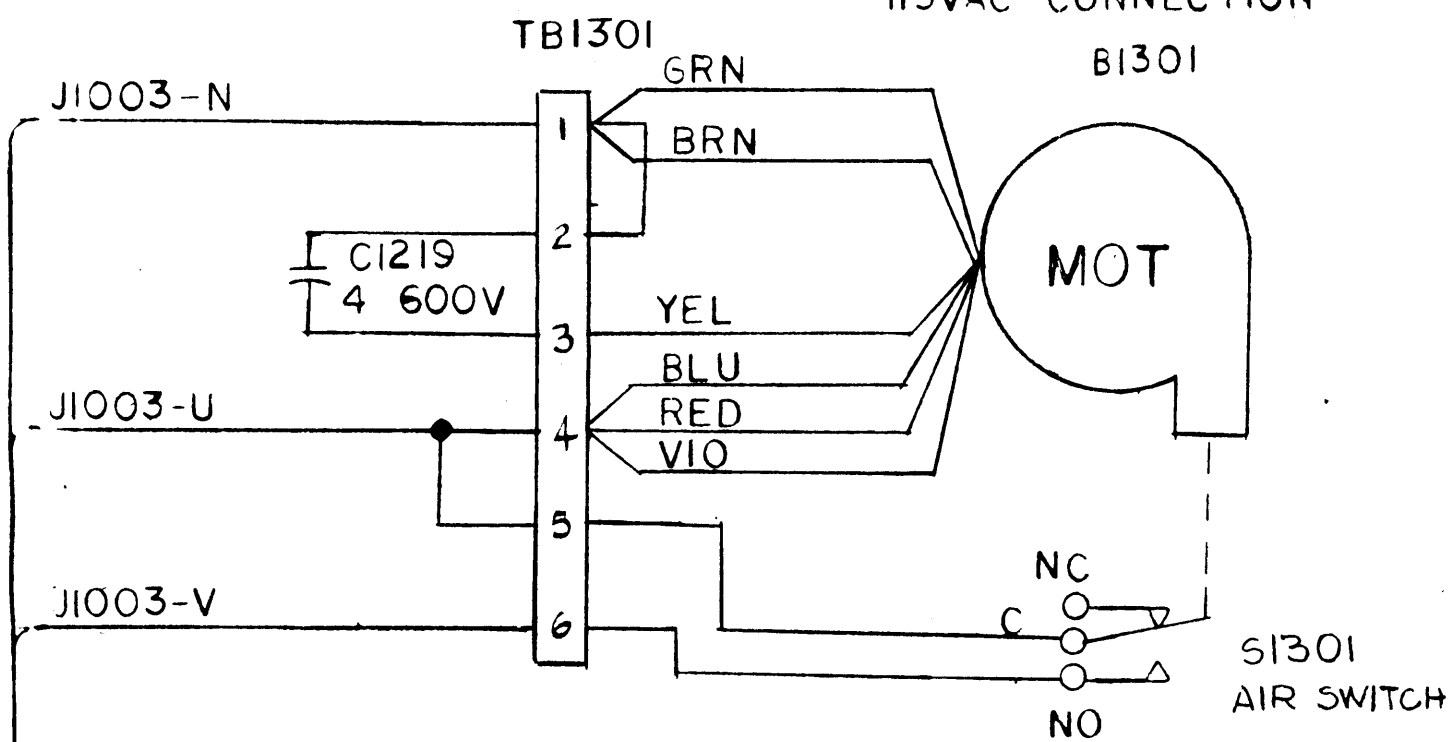

S1001 PLATE CURRENT

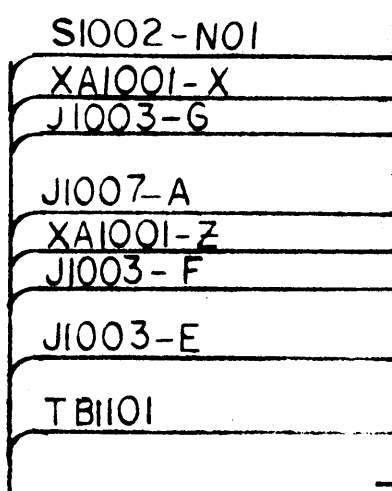
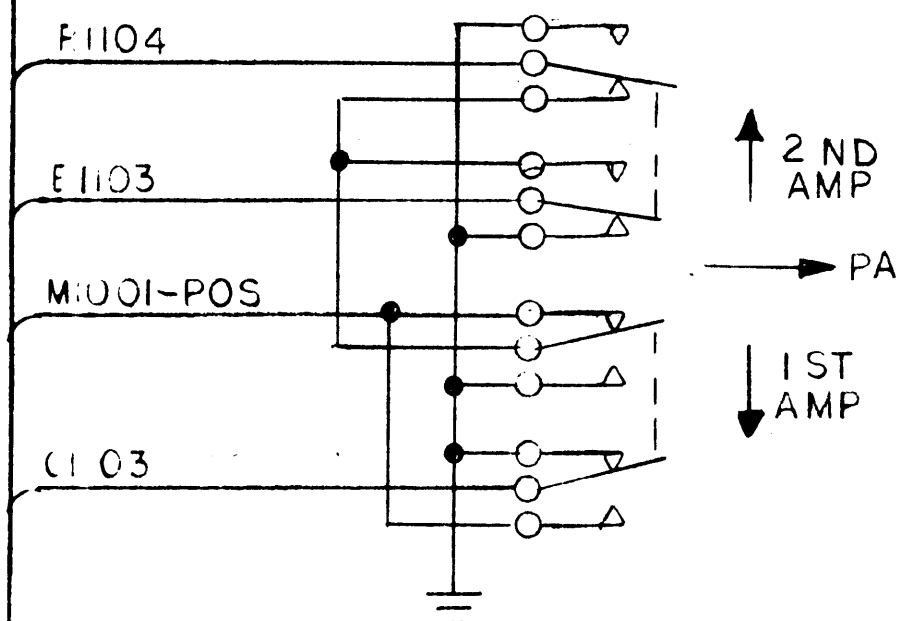

M1001 PLATE CURRENT

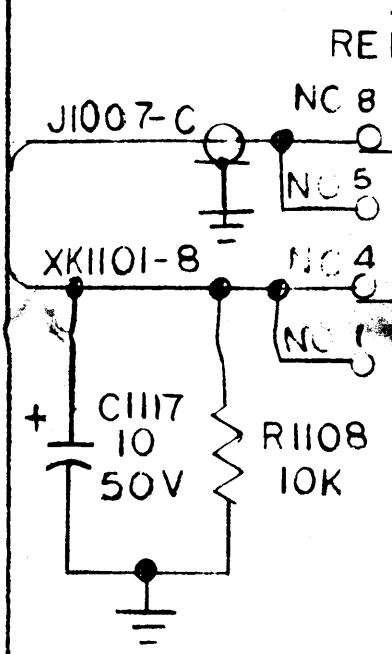
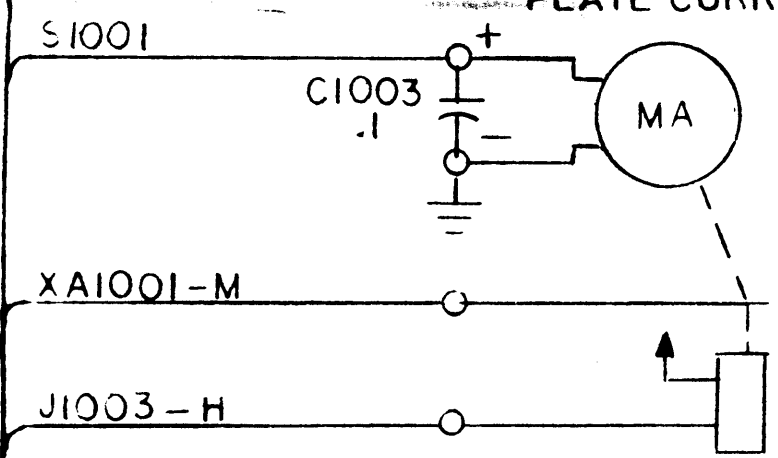

TIME DELAY

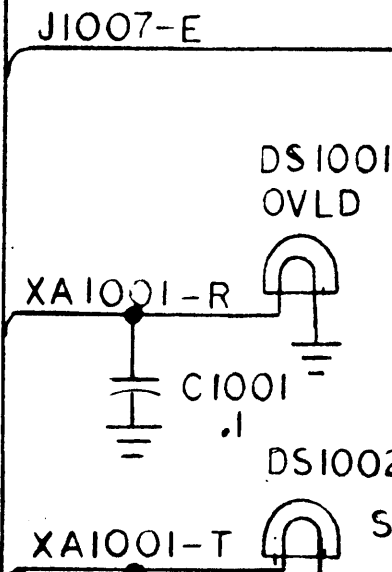
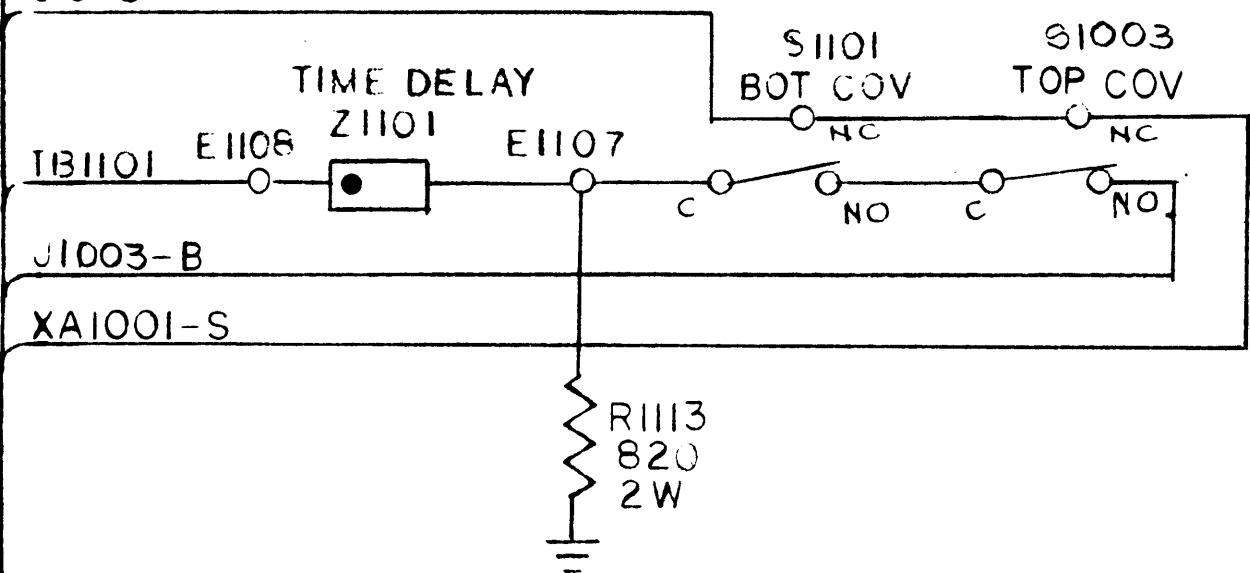

230 VAC CONNECTION

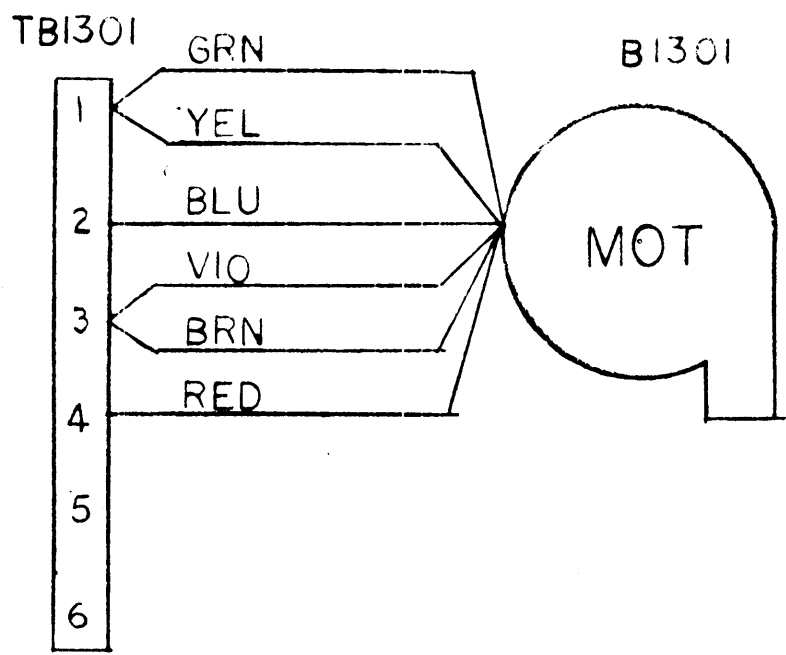

\*  
\*  
ONE PAIR OF LEADS ONLY IS USED.  
IF TFP-1K IS USED IN SYSTEM, DC1001  
IS REMOVED. UNUSED PAIR IS TIED  
BACK.

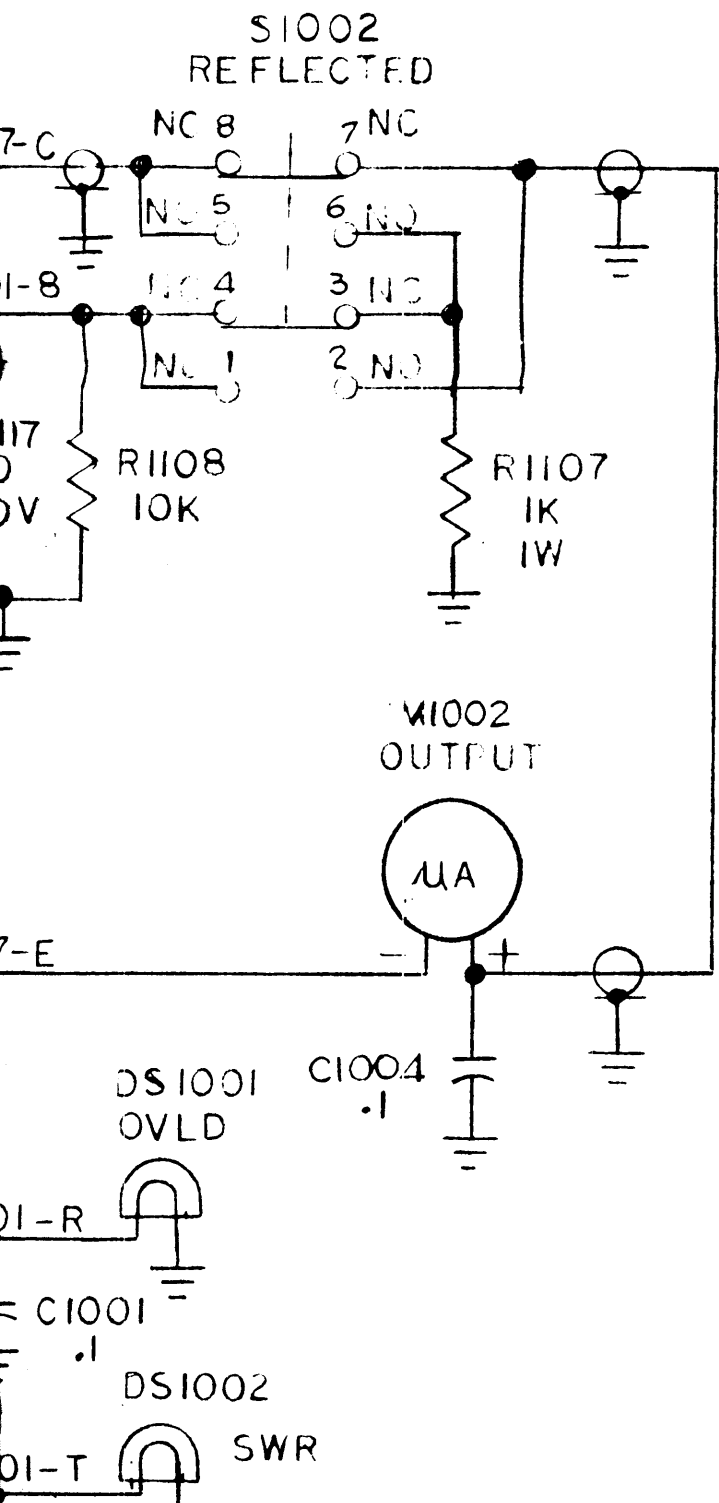
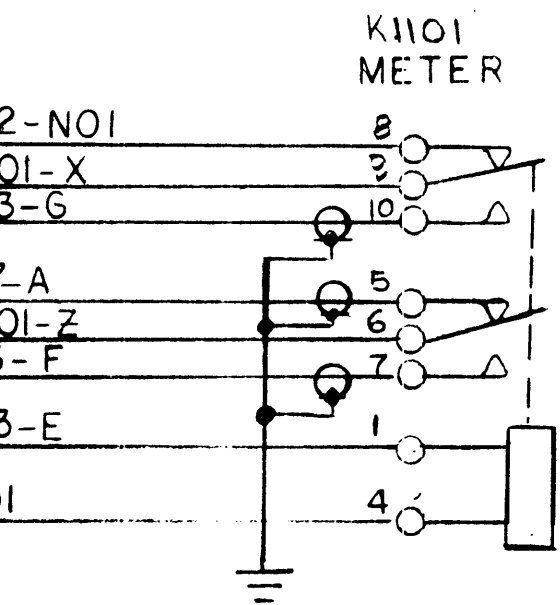

A1001 OVLD

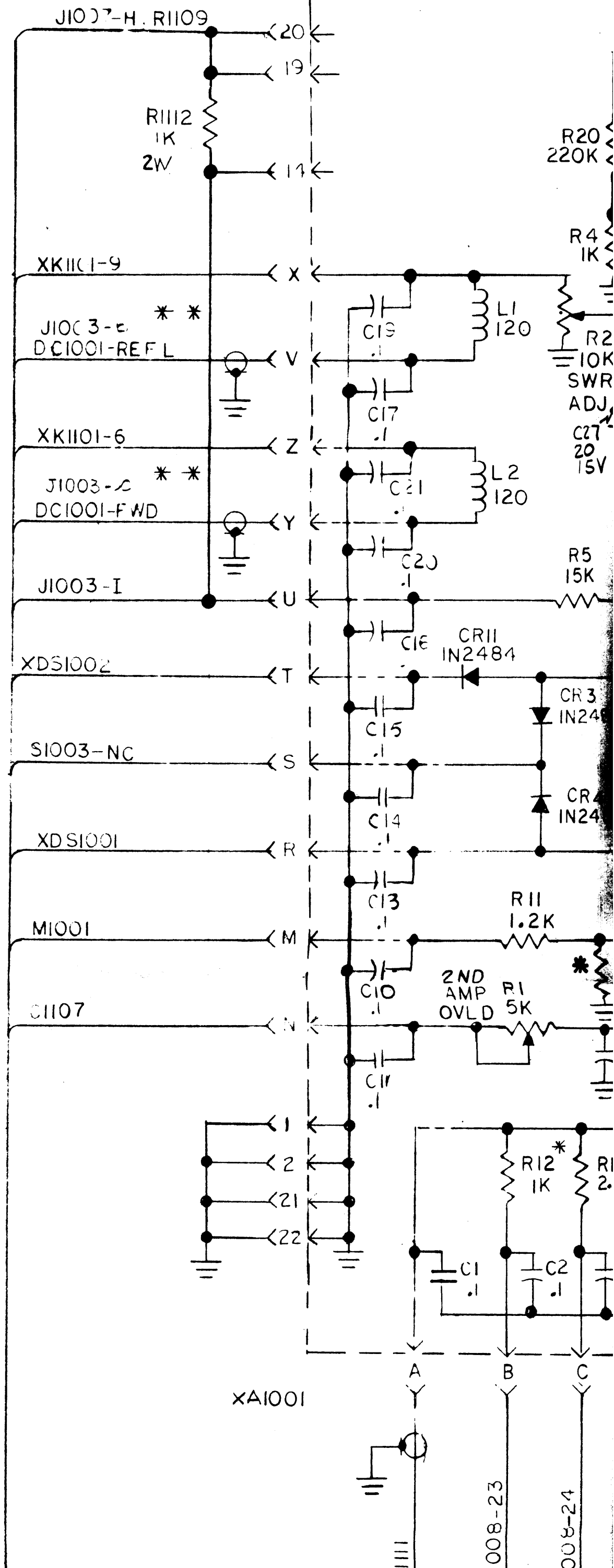



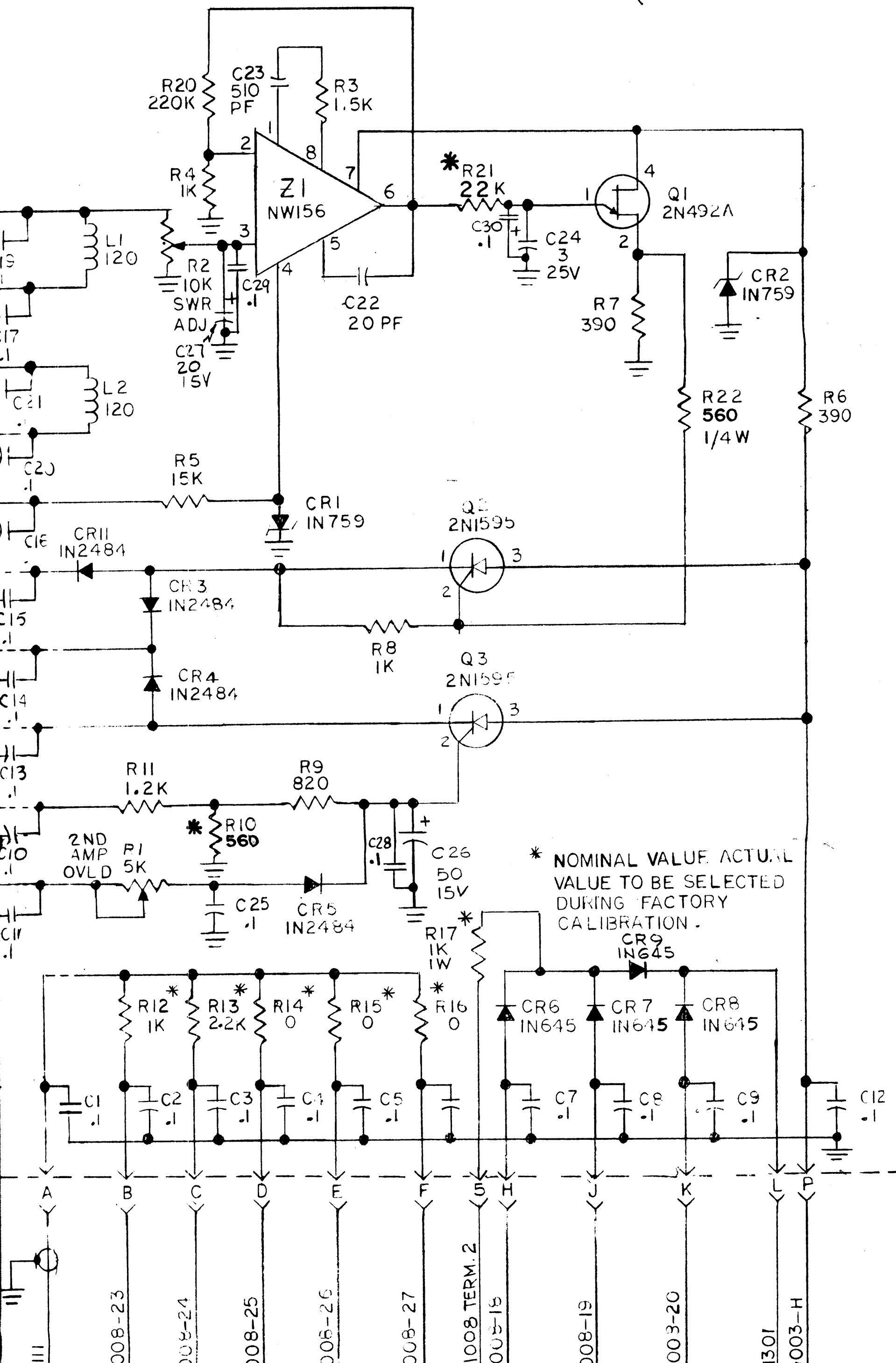

(A4879/PC600)

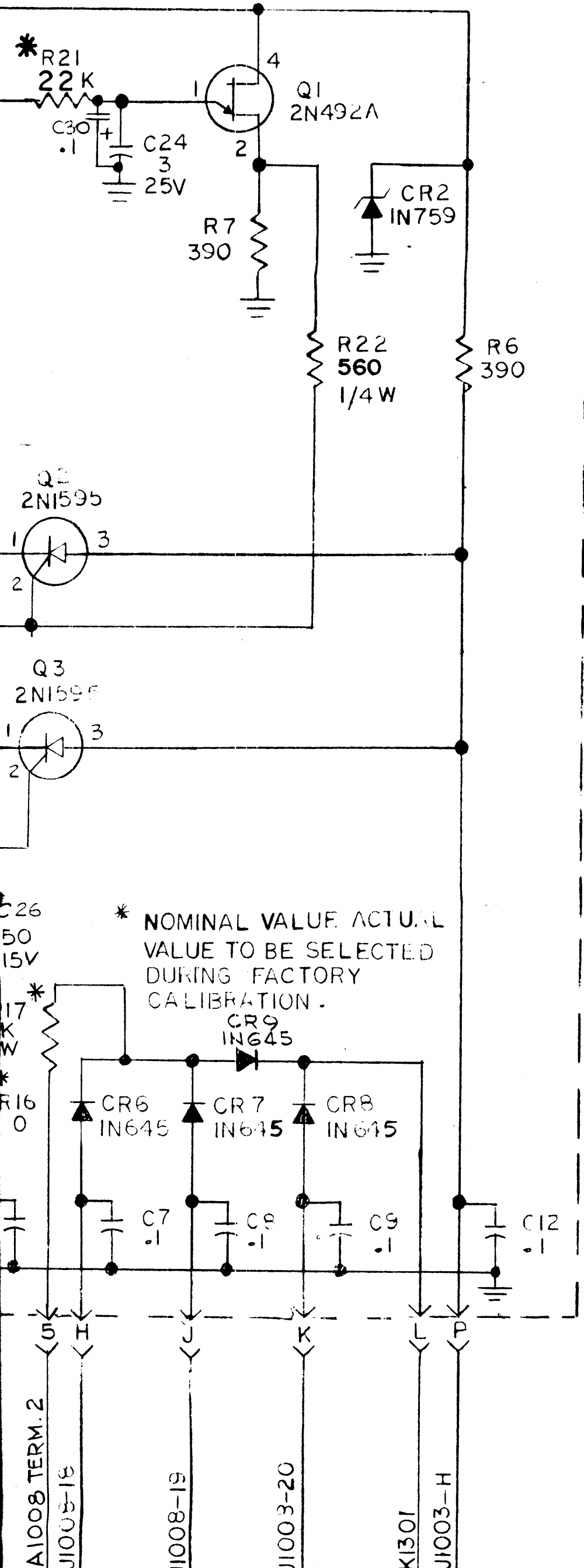

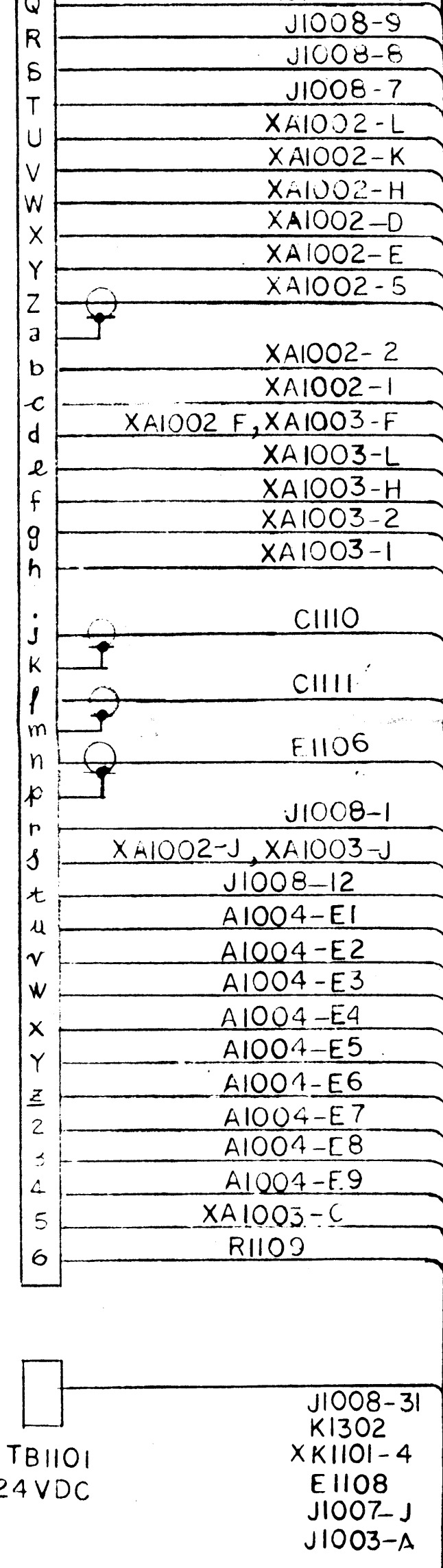
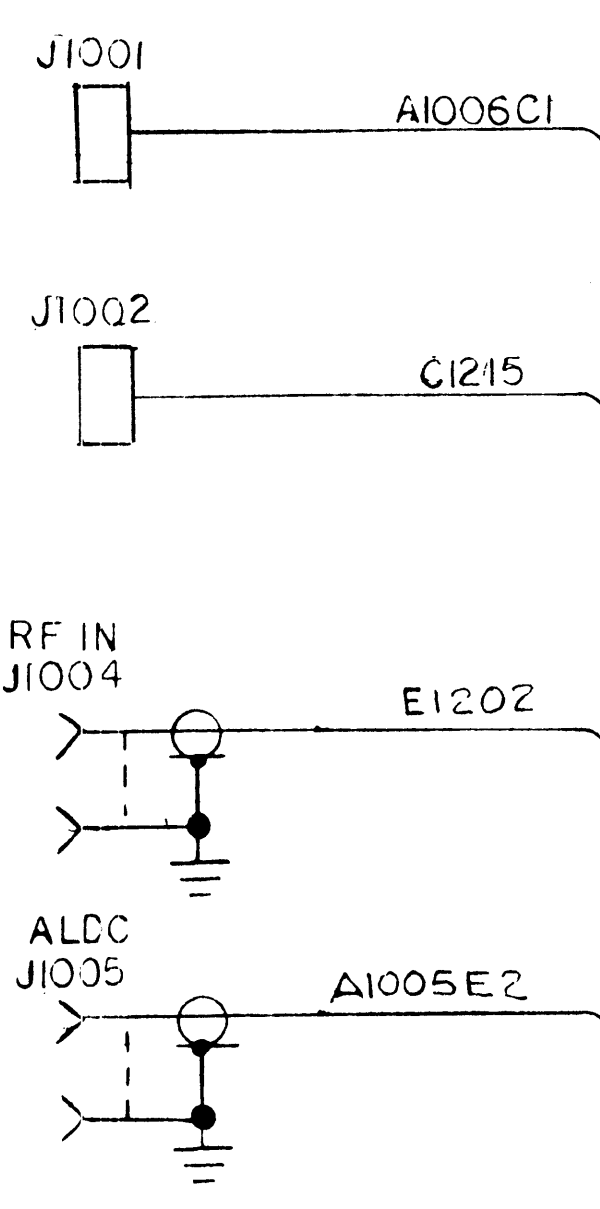
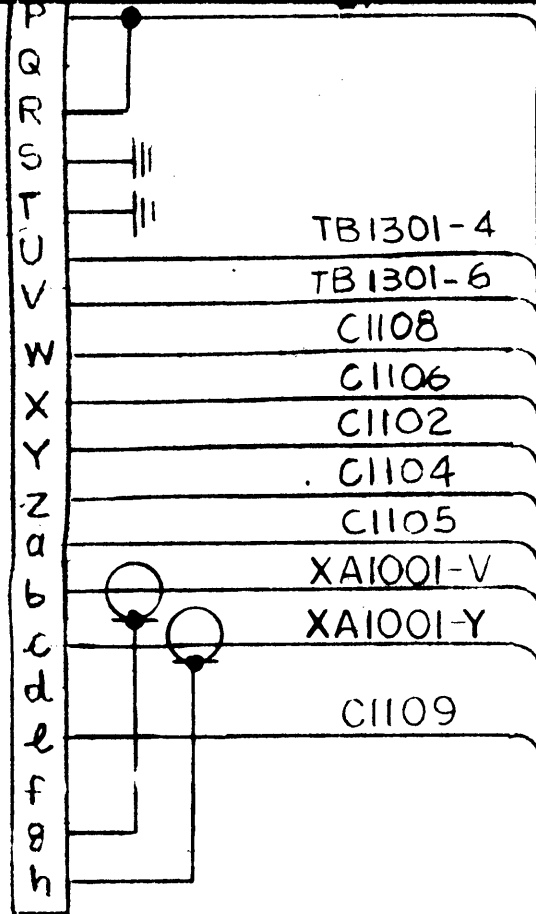

1000	
LAST	MISSING
A1007	
C1006	
DC1001	
DS1002	
J1008	
L1001	
M1002	
S1003	
XDS1002	
XA1003	

A1001	
LAST	MISSING
C27	C18
CR11	CR10
L2	
Q3	
R22	R18
Z1	R19

A1002	
LAST	MISSING
A1	
B1	
C1	
S2	

A1003	
LAST	MISSING
A1	
B1	
C1	
S2	

A1002A1 A1003A1	
LAST	MISSING
C13	
E12	

S1001  
PLATE CURRENT

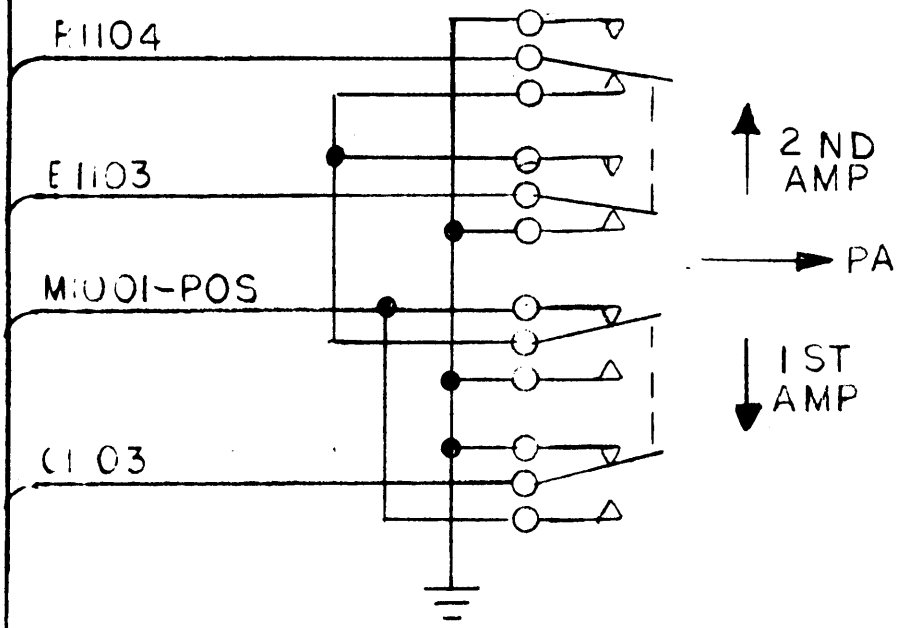

M1001  
PLATE CURRENT

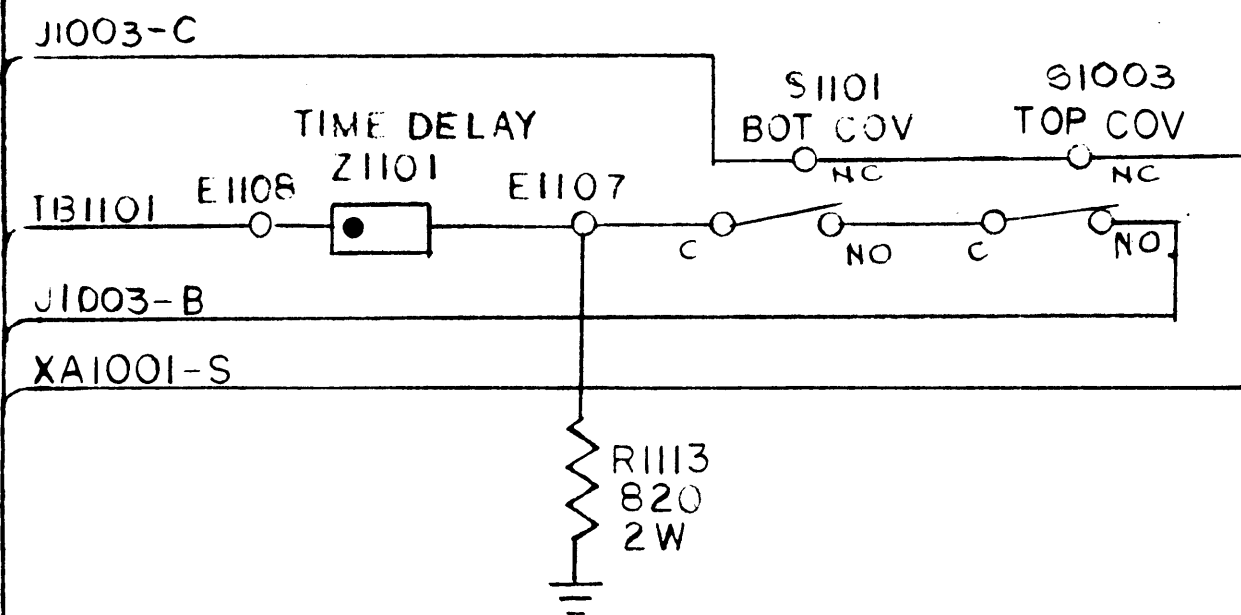
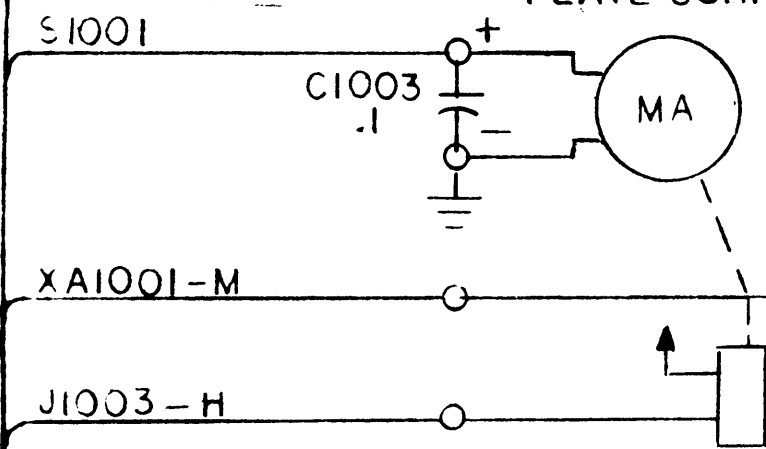

S1002-N01

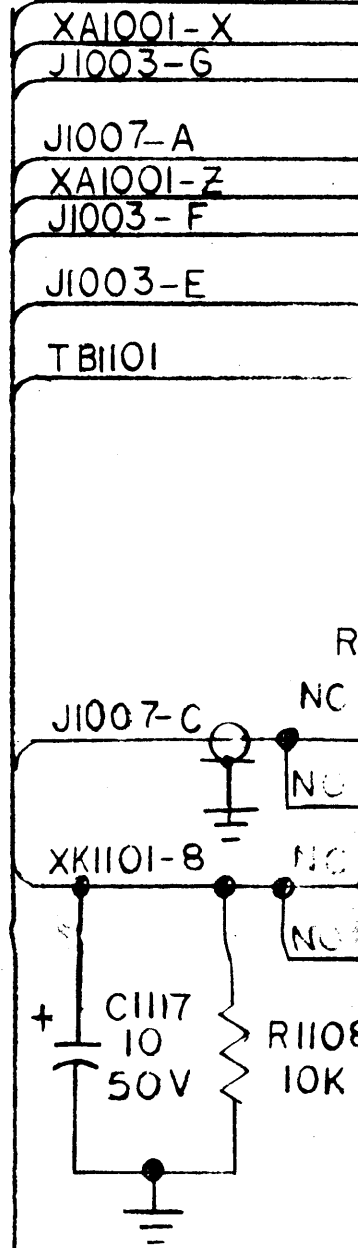

J1007-E

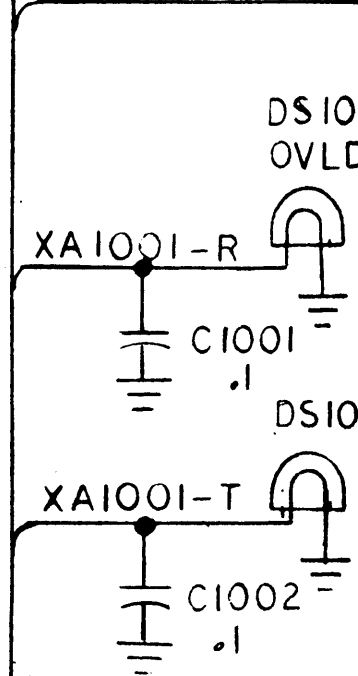

A1003A1	A1004		A1005		A1006		A1007		I100		I2
MISSING	LAST	MISSING	LAST	MISSING	LAST	MISSING	LAST	MISSING	LAST	MISSING	LAST
	C9		C3		C8		C5		C1117	C1113	C1220
	CR9		CR1		CR1		CR4		CR1102	C1114	E1208
	DS9		R2		E2		L1		E1108	E1101	L1207
	E10				K1		R8		K1101		R1214
	R1				L3				R1113		T1201
					P1				S1101		V1202
					S2				TB1101		XV1202
					XK1				XK1101		Z1202
									Z1101		

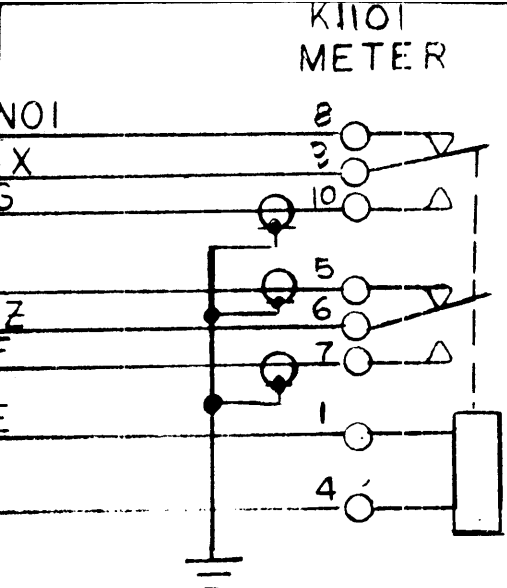

\* ONE PAIR  
\* IF TFP-1K  
IS REMOVED  
BACK.

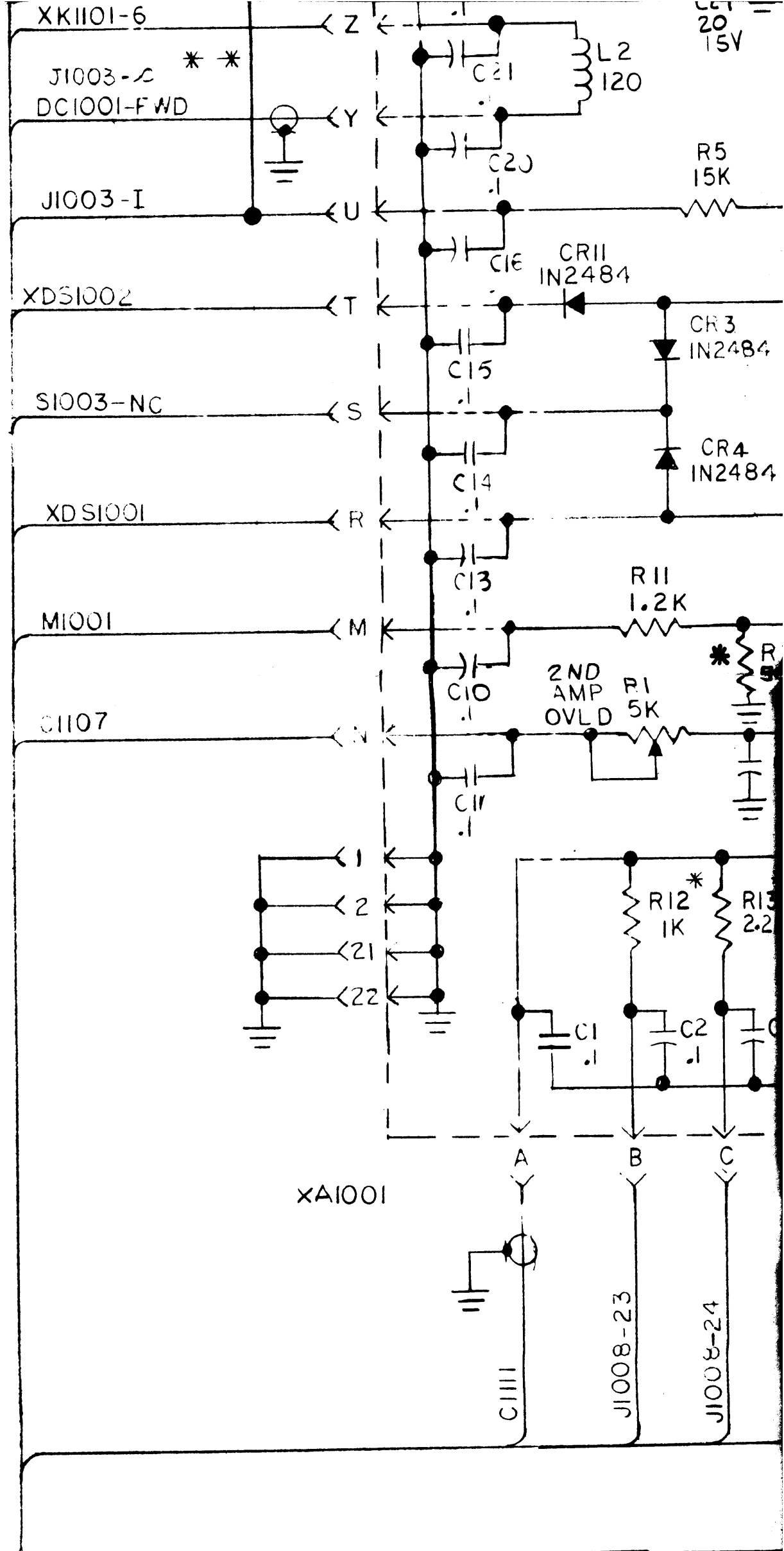
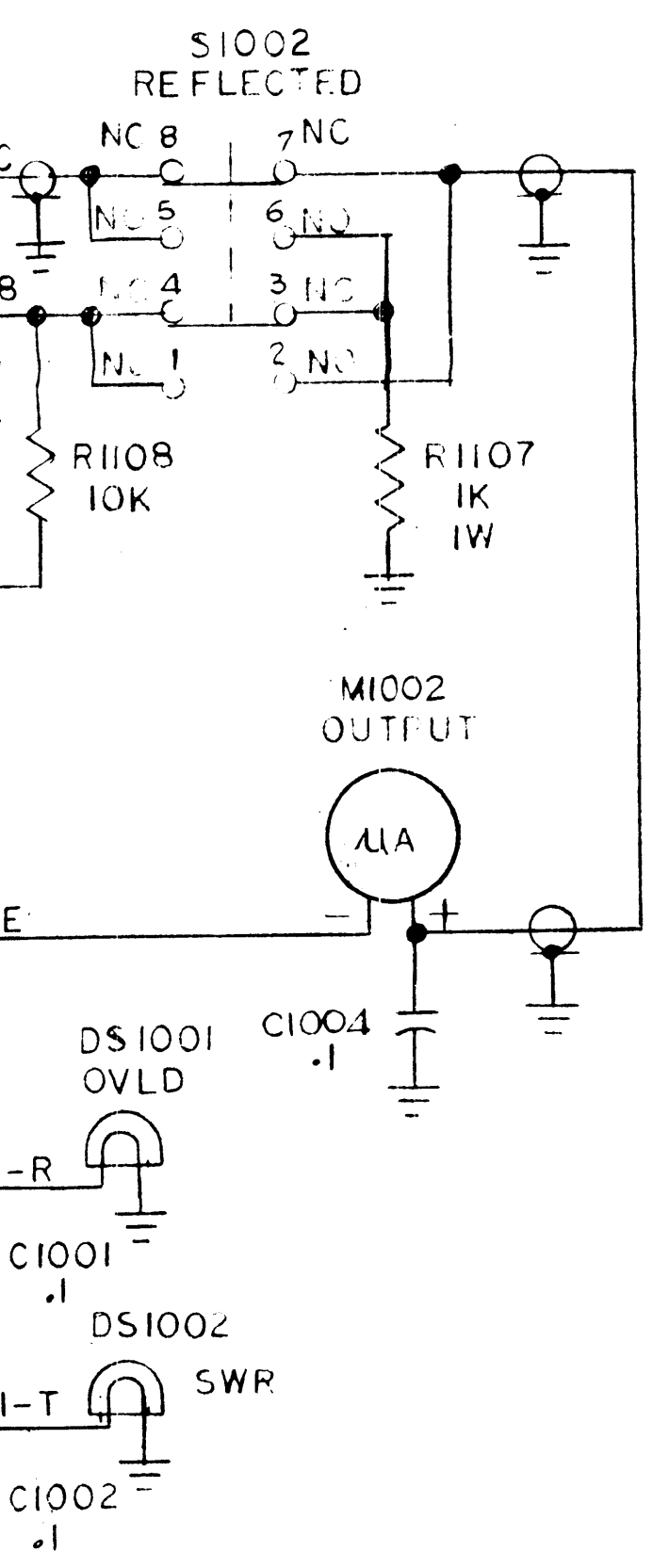

1200	
LAST	MISSING
C1220	
E1208	
L1207	L1201
R1214	
T1201	
V1202	
XV1202	
Z1202	

1300	
LAST	MISSING
B1301	C1301, 2, 4, 5, 6
C1323	
E1302	
L1307	K1301, K1302
R1302	R1301
S1301	
T1301	
TB1301	
V1301	
XV1301	

A1008	
LAST	MISSING
C7	
CR1	
E4	
K3	
L1	
R1	

ZONE	LTR	DESCRIPTION
A1001	P	C28, C29 and C30 Added
A1001	N	R21 WAS 470K, R22 WAS 5.6K, R10
	M	SEE SH 3 OF 3
	L	SEE SH. 3
	K	TO A4379 ADD CR9, R17 & PIN 5. SEE SHEETS 2 & 3
	J	RELIN W/OUT CHANGE

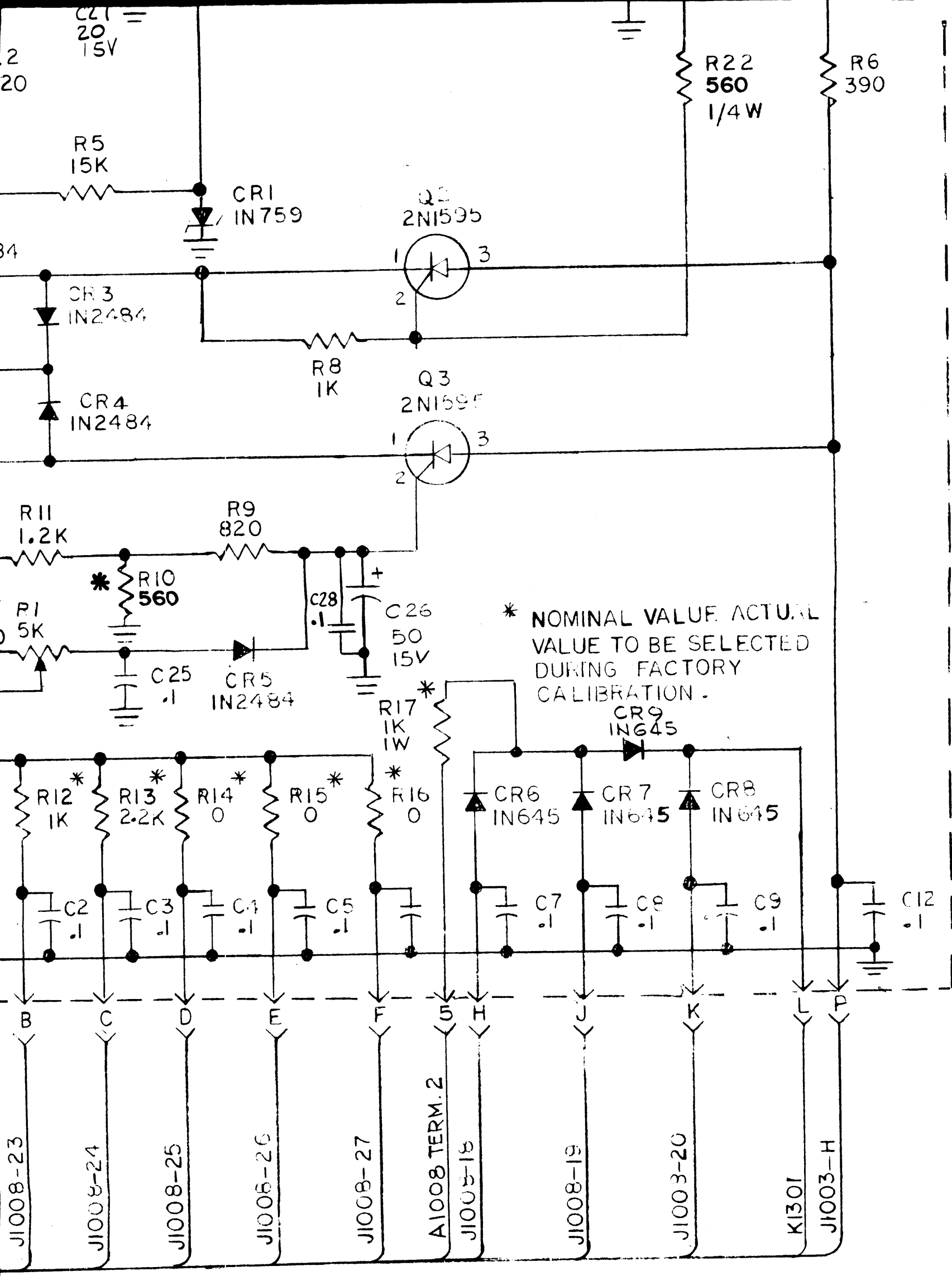

TO SH. 2

C30 Added	56-83	22022	WLD	
R22 WAS 5.6K, R10 WAS 120	3-2-82	21931	eu	
DEF3	6-17-78	21652	GDL	
		21407		
CR9, R17 & SHEETS 2 & 3	5-2-76	21415	GDL	
OUT CHANGE	2-2-77	21327	GDL	
REVISIONS				
DESCRIPTION	DATE	E.M.N.NO	DRAFT	CHKD. APPD.

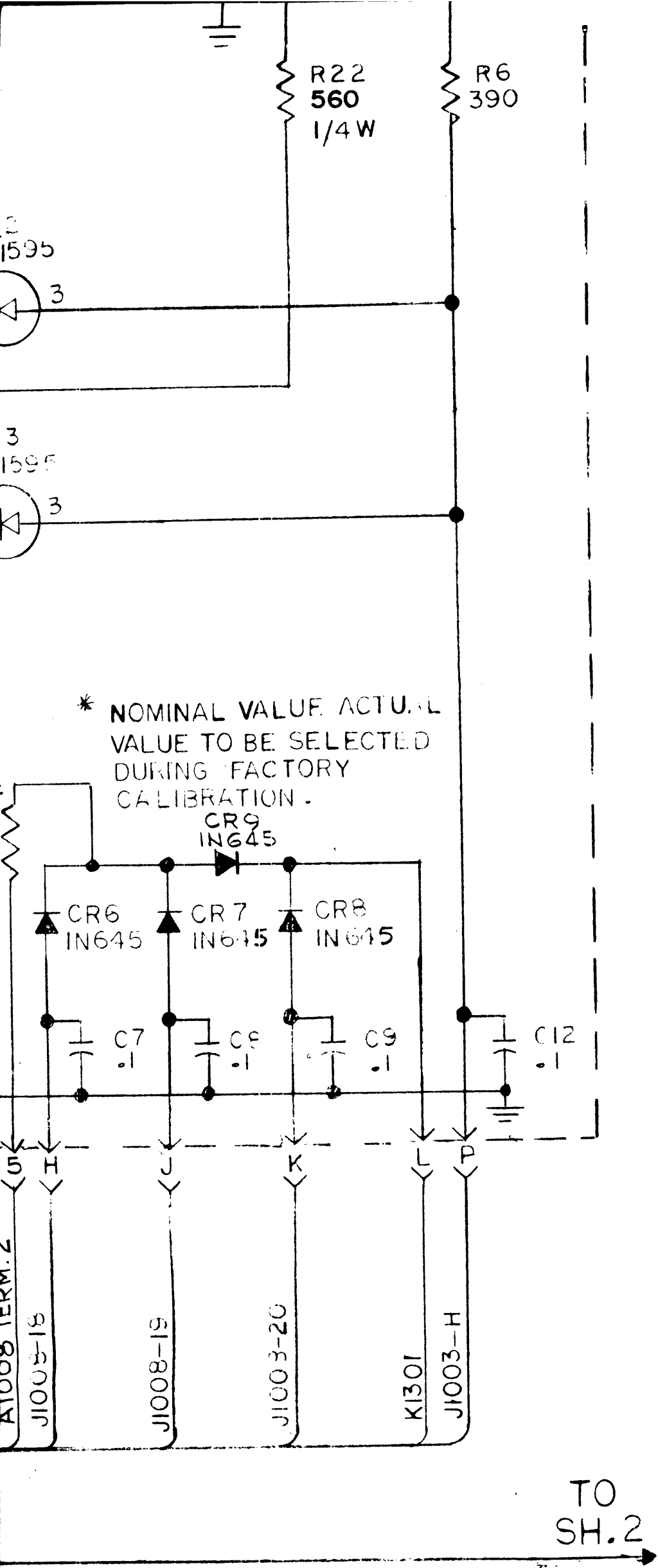

Schematic Diagram,  
 Power Amplifier TLAA-1K  
 (Sheet 1 of 3)

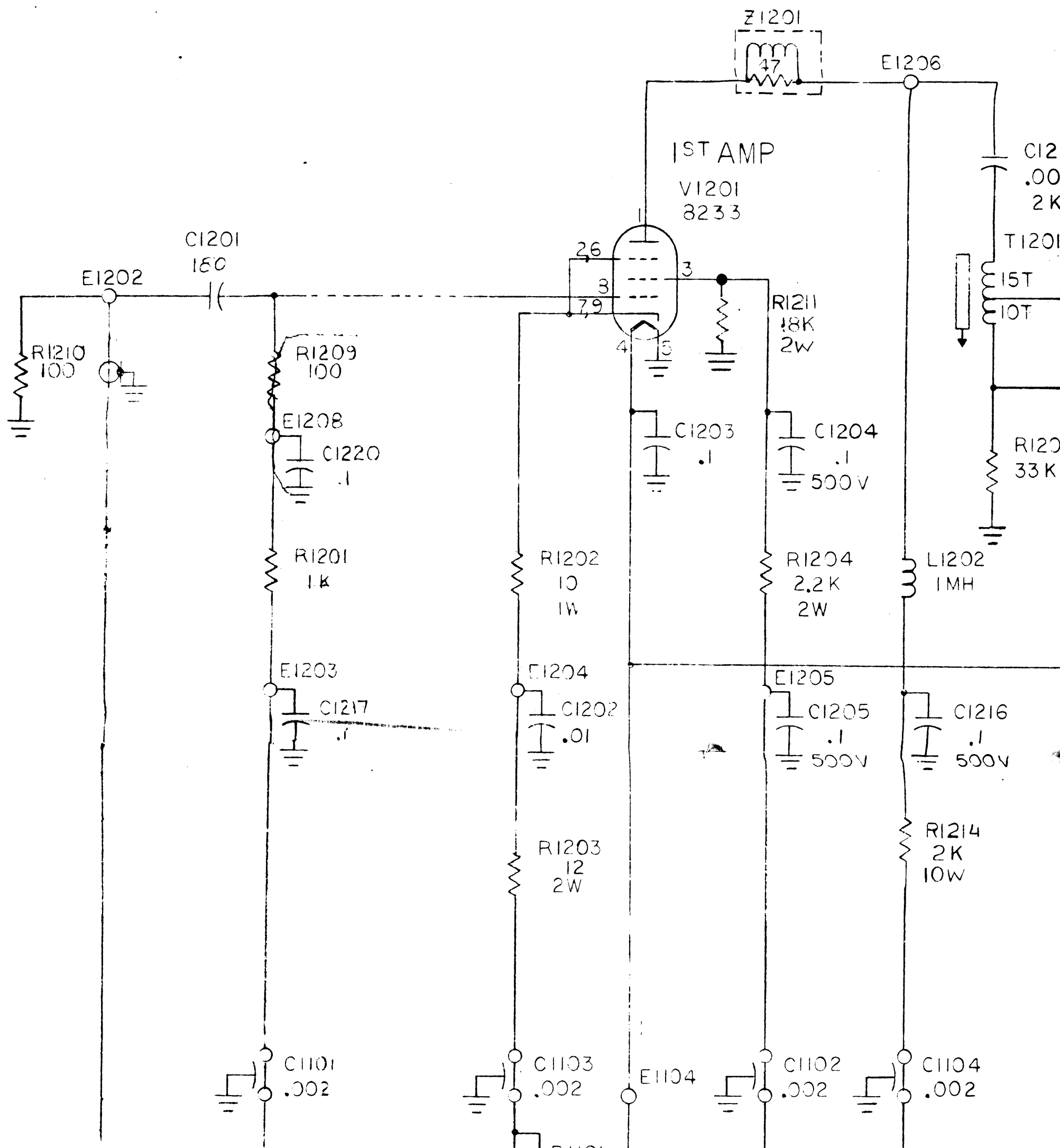



AX787

8-25

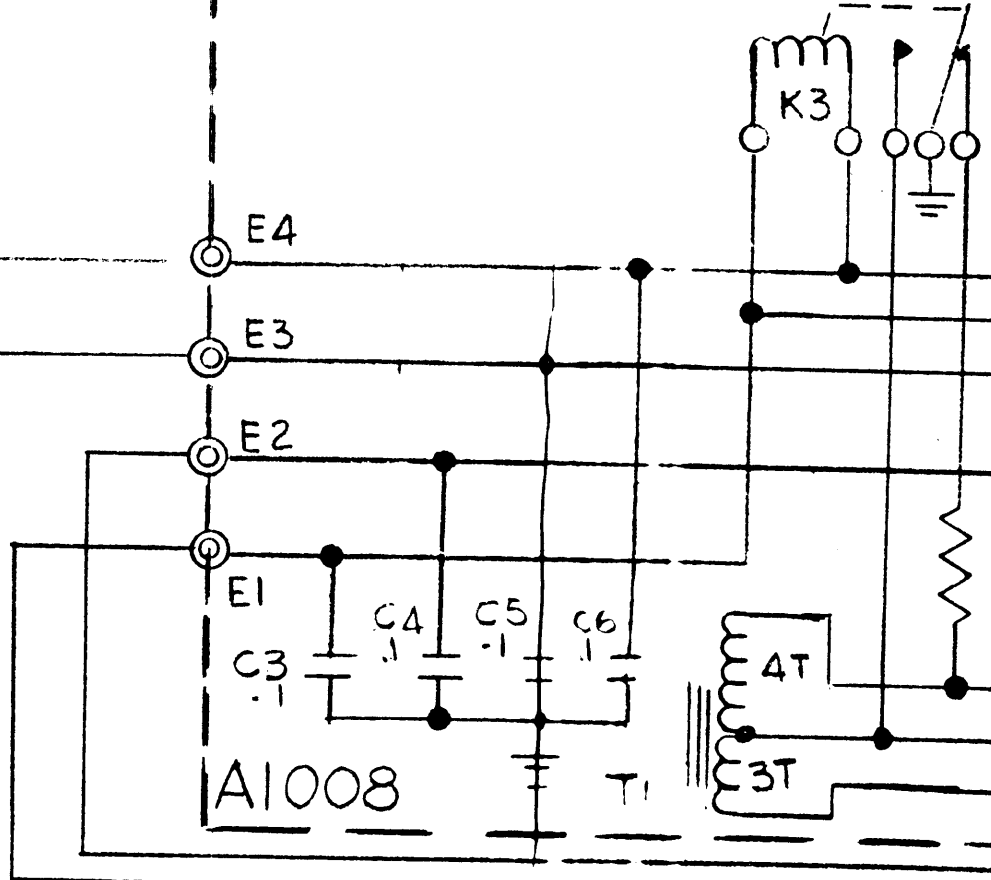

L1206  
4.5  
m

06

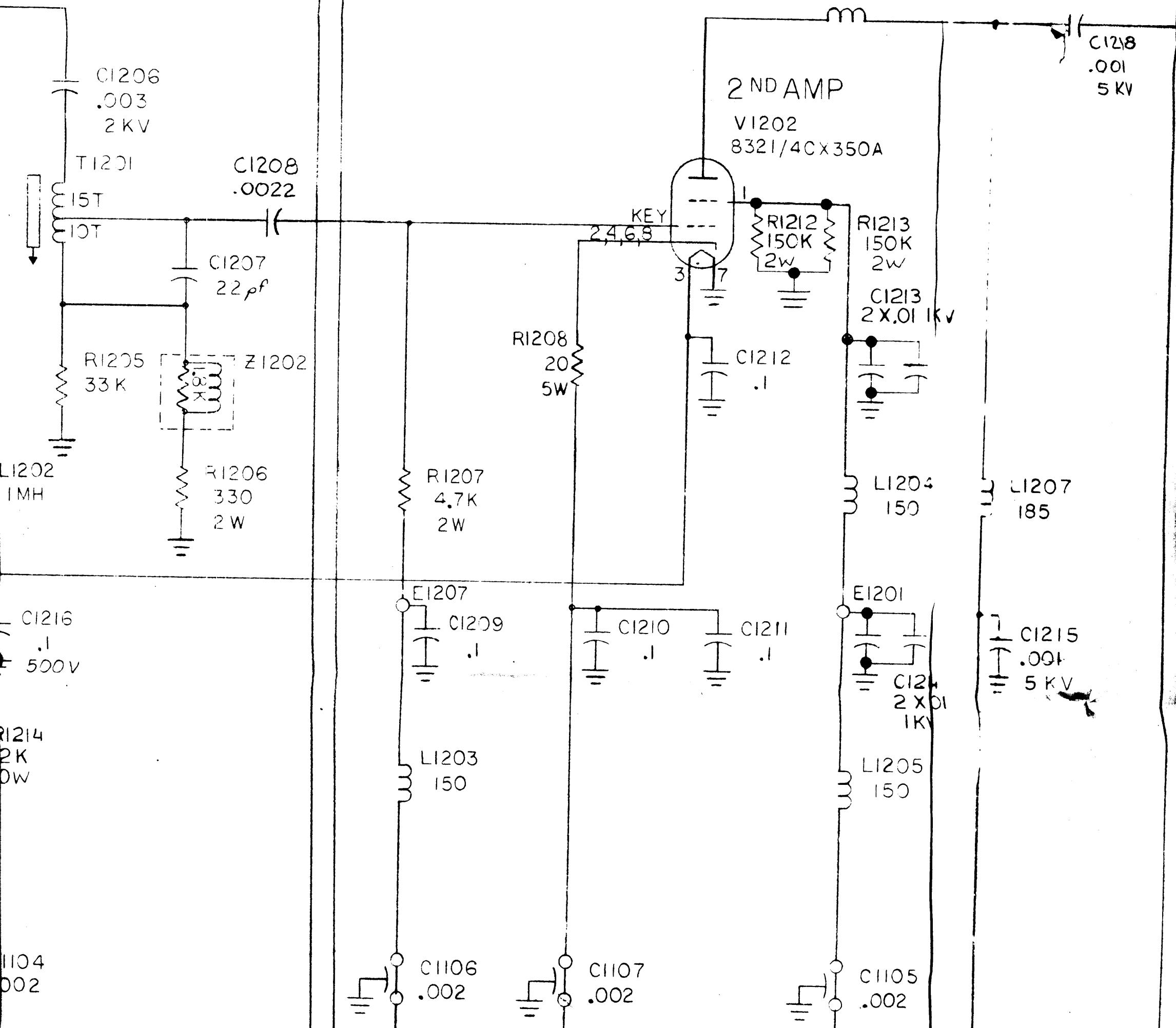

2ND AMP

V1202  
8321/4CX350A

C1218  
.001  
5KV

C1206  
.003  
2KV

C1208  
.0022

C1207  
22pf

R1205  
33K

Z1202

R1206  
330  
2W

R1208  
20  
5W

R1207  
4.7K  
2W

R1212  
150K  
2W

R1213  
150K  
2W

C1213  
2 X .01  
1KV

C1212  
.1

L1204  
150

L1207  
185

C1216  
.1  
500V

E1207  
C1209  
.1

C1210  
.1

C1211  
.1

E1201  
C1214  
2 X .01  
1KV

C1215  
.001  
5KV

L1203  
150

L1205  
150

R1214  
2K  
0W

1104  
002

C1106  
.002

C1107  
.002

C1105  
.002

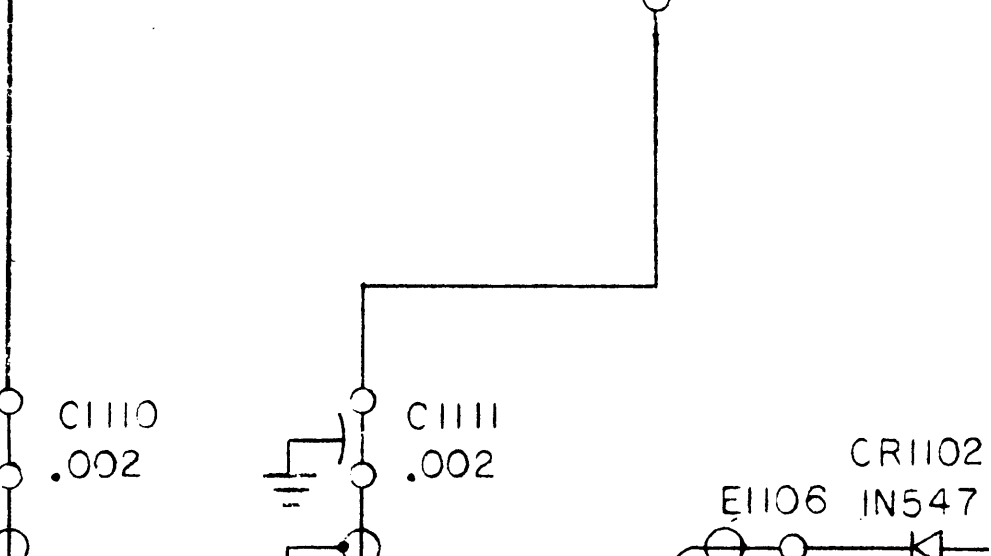
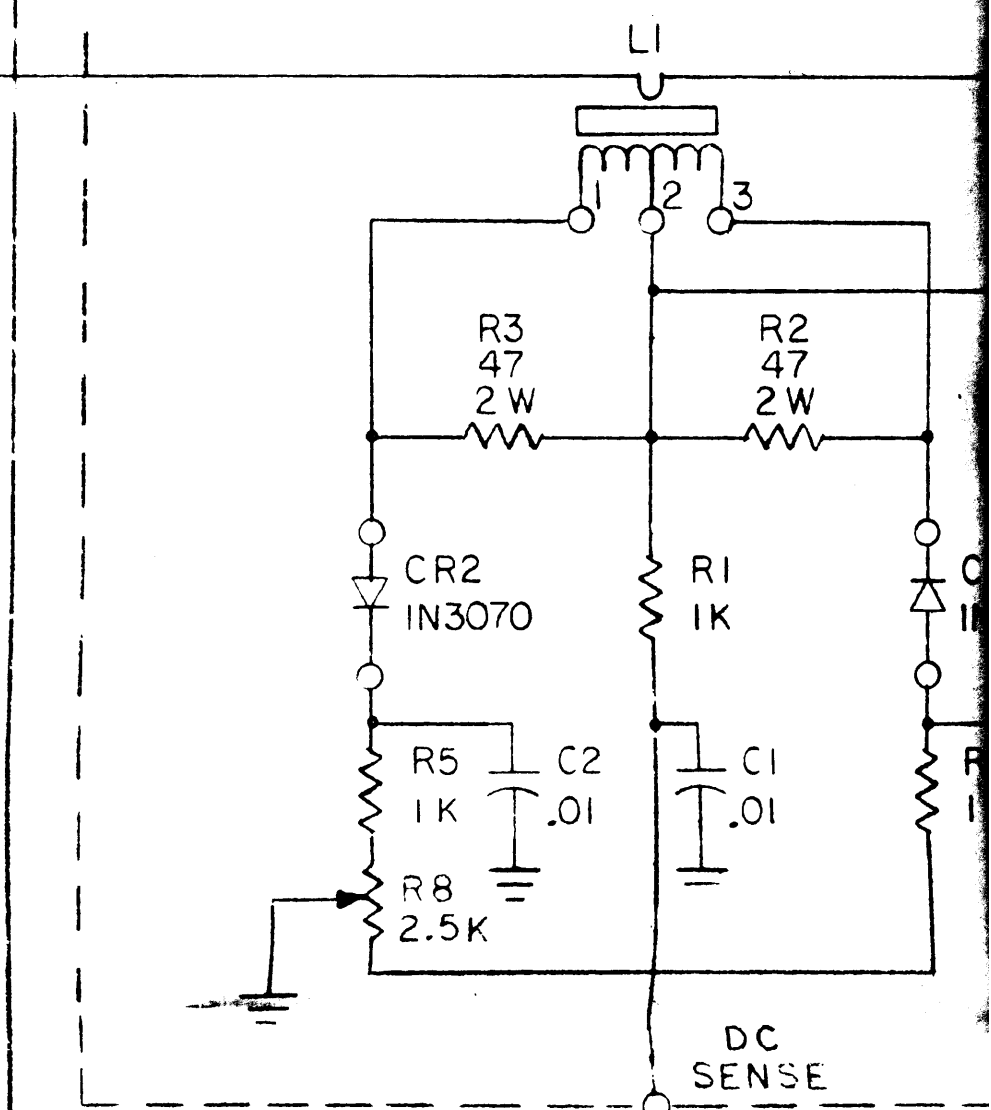
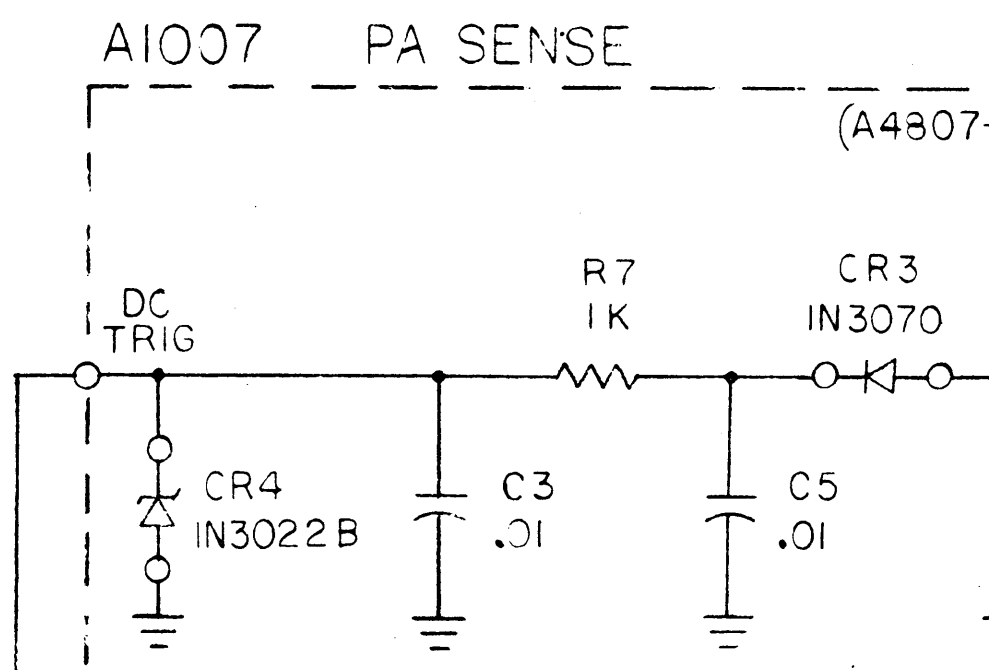
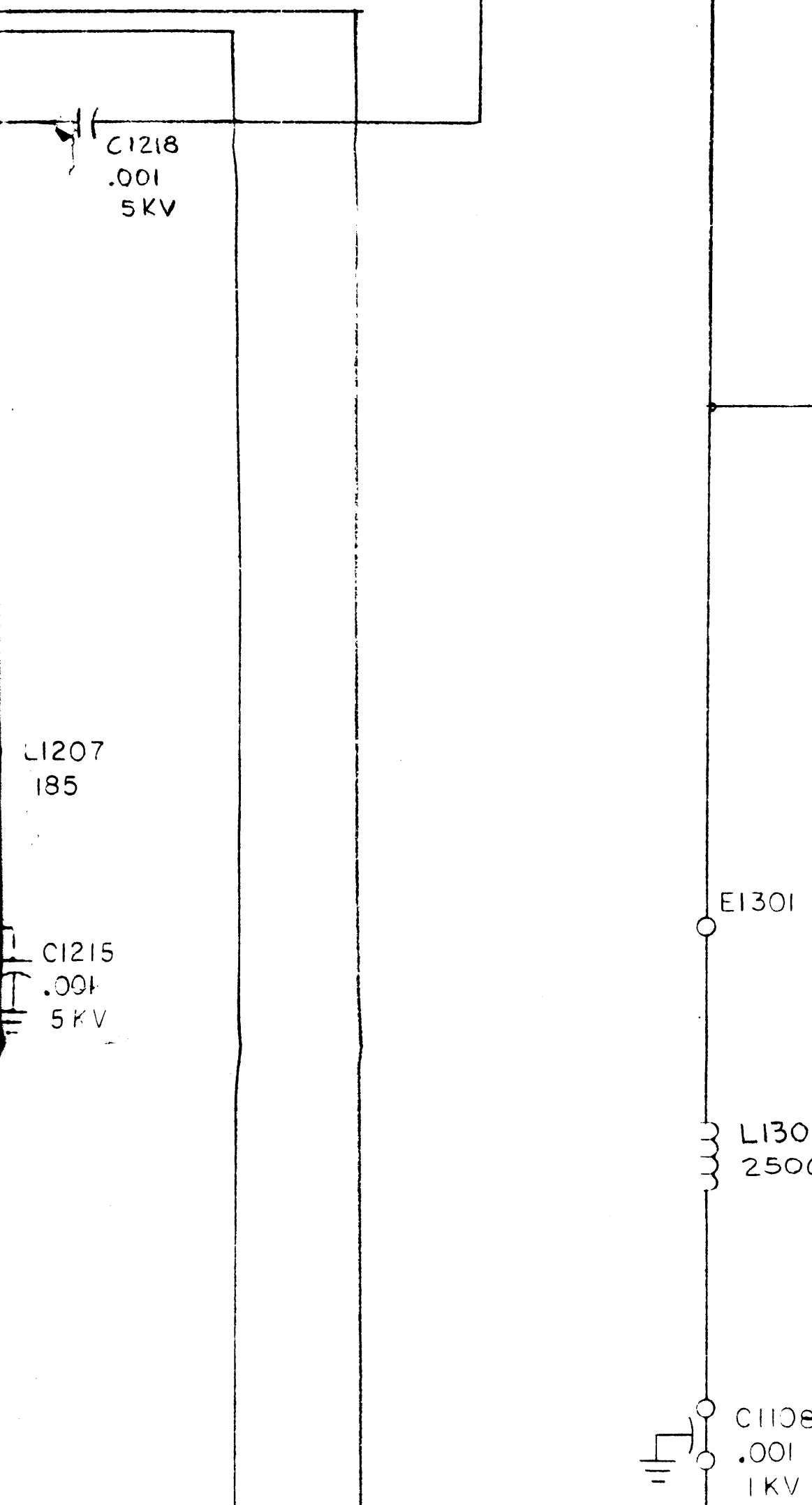
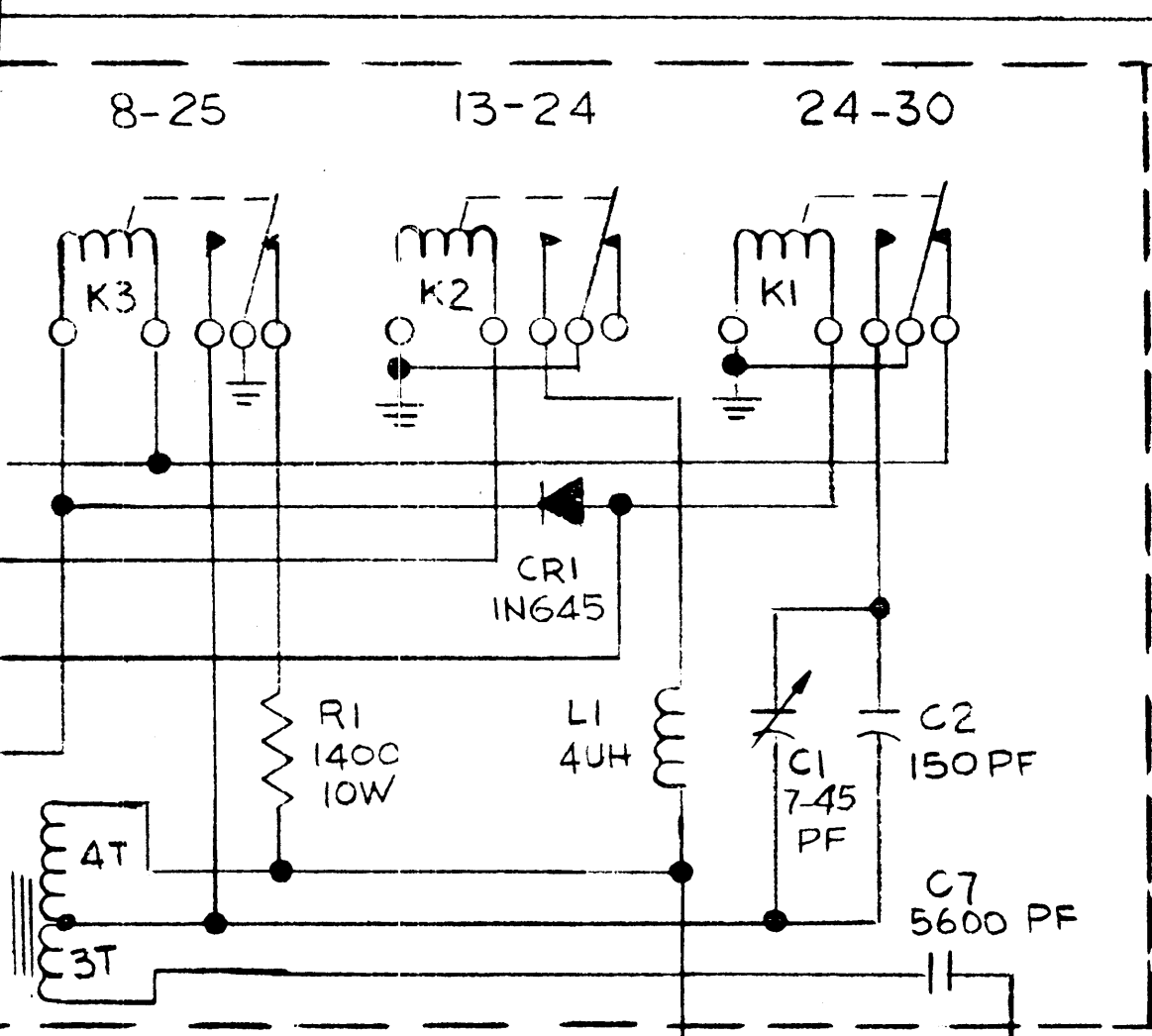

ENSE

(A4807-2/PC535)

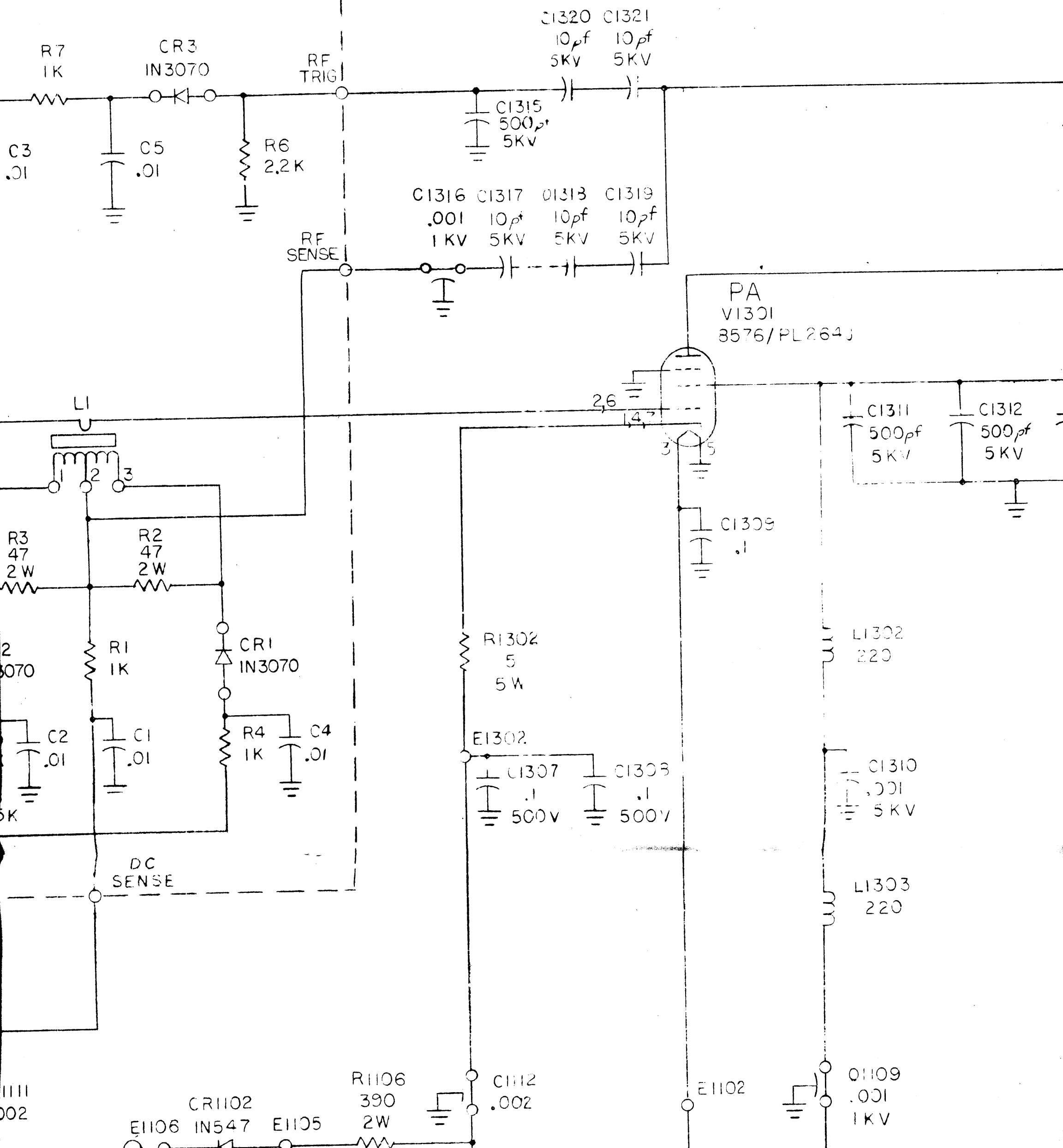

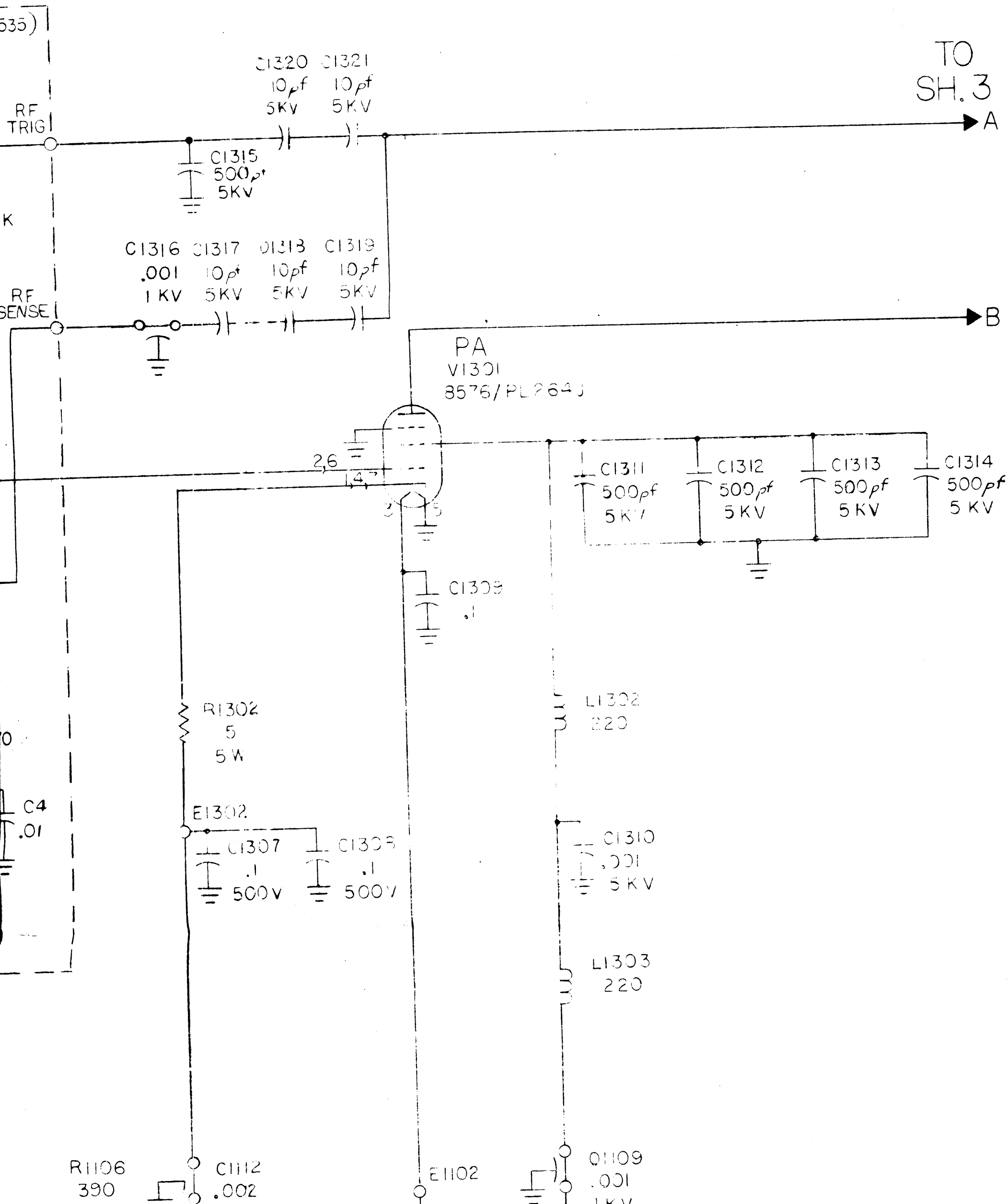

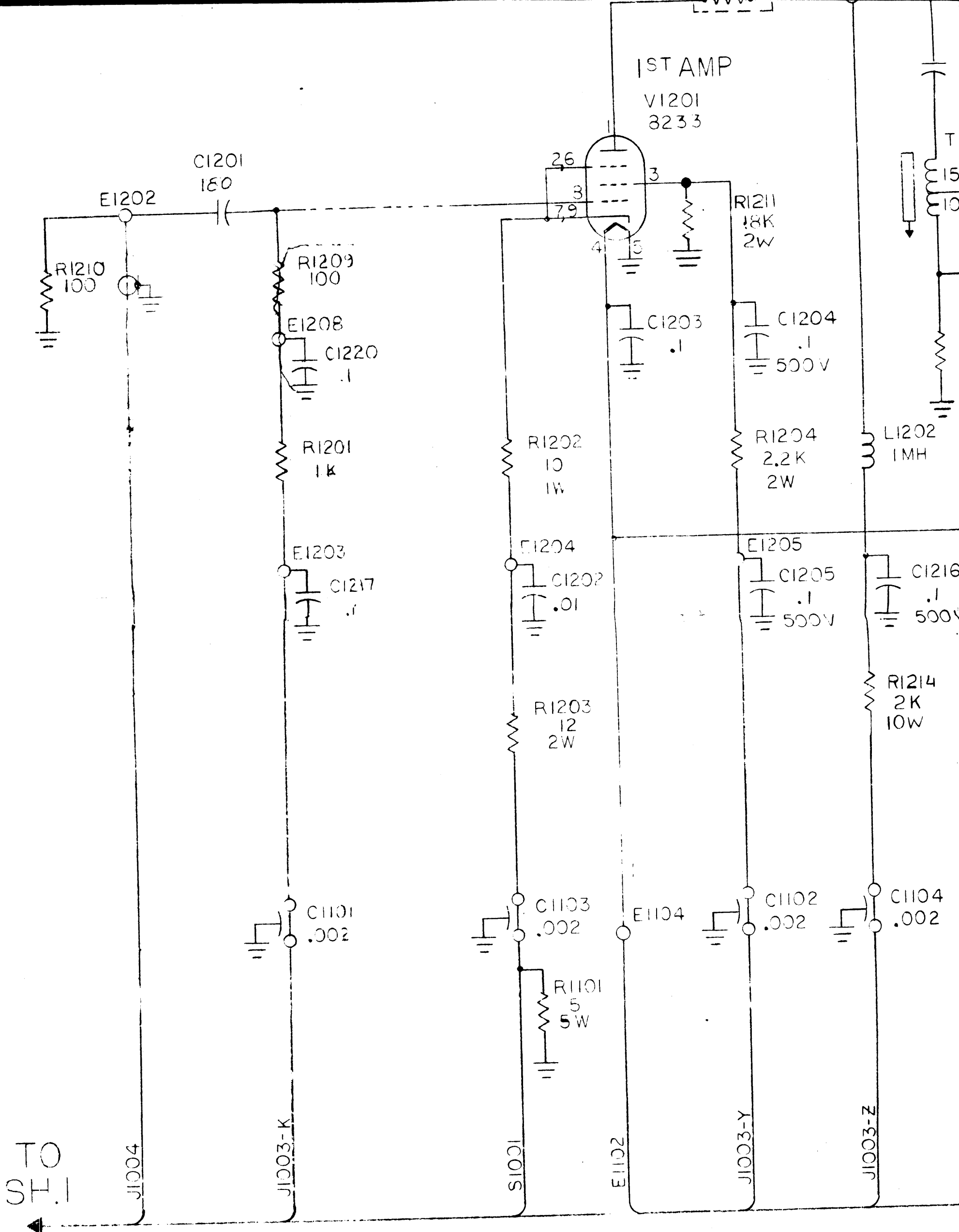

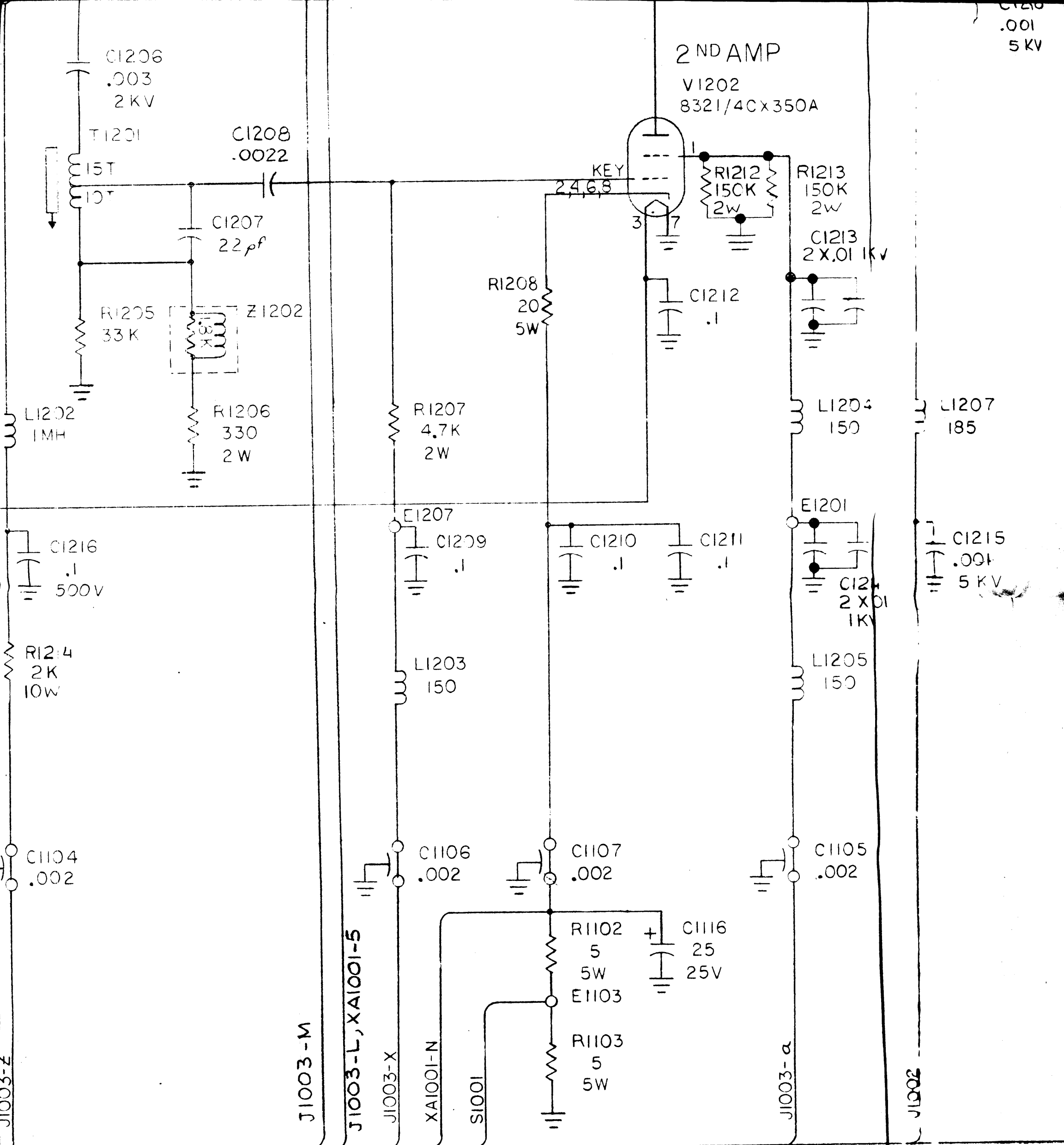

UNLESS OTHERWISE SPECIFIED:  
 1. ALL RESISTANCES ARE IN OHMS, 1/2 W.  
 2. ALL INDUCTANCES ARE IN MICROHENRIES.  
 3. ALL CAPACITANCES ARE IN MICROFARADS.  
 4. PARTIAL REFERENCE DESIGNATIONS ARE SHOWN. FOR COMPLETE DESIGNATION, PREFIX THE PART DESIGNATION WITH THE SUB-ASSEMBLY DESIGNATION.

C1215  
.001  
5KV

207  
35  
C1215  
001  
5KV

XA1001-L

J1008-21

J1003-W

J1007-j

J1007-1  
XA1001-A

J1007-n

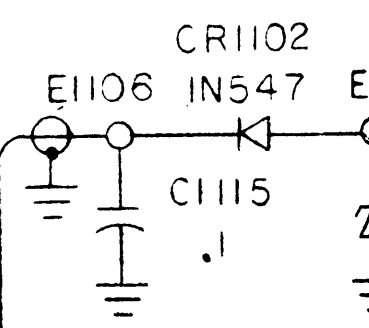
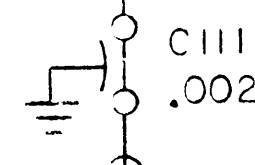
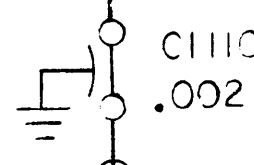
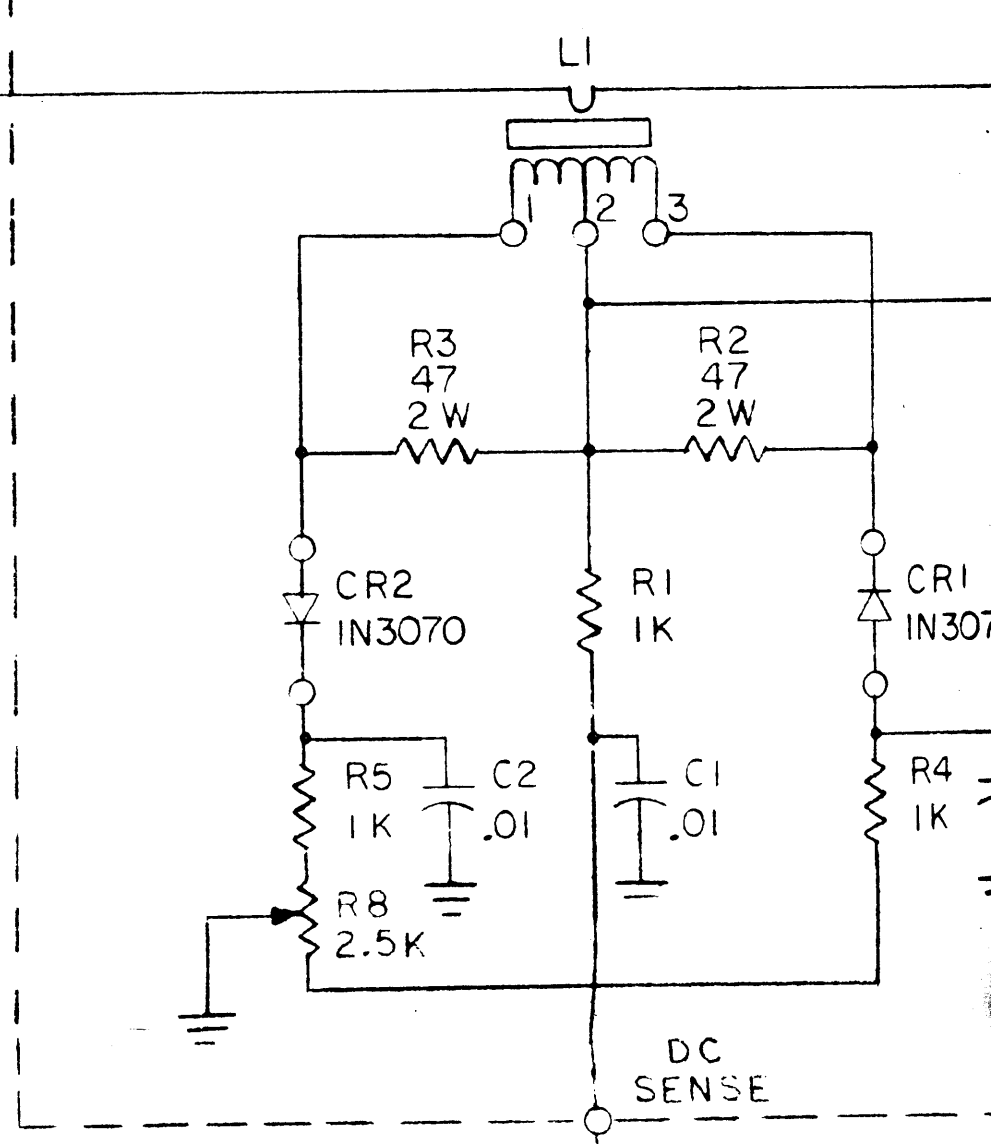

REVISIONS							
ZONE	LTR	DESCRIPTION	DATE	E.M.N.NO	DRAFT	CHKD	APPD
	X2	ADD C1304, R1303. DELE A1007C6	2/20/71				
	Z	ORIG RELEASE FOR PROD	10/11/71				
	A	ADDED R1208, 90, SW, C1306 WAS 220 R1302 WAS CONNECTED TO T1301, 3T	11/17/71	20486			
	B	ADD C1303	2/19/72	20534			
	C	DELE C1303, & ASSOCIATED NOTE	4/24/72	20626			
	D	CHG C1213 & C1214	5/3/72	20671			
	E	CHG C1201 VALUE WAS 300	10/13/72	20908			
	F	ADD R1211, R1214, R1212 & R1213	10/30/72	20933			
	G	SEE SHEET 1	1/3/74	21108			
	H	ADD R8 TO A1007	2/11/74	21138			
	K	DEL. T1301, C1301, 2, 3, 4, 5, C1306, K1301, K1302, R1301, R1303 ADD A1008 & L1305. SEE SH 1 & 2	5-21-76	21415			
	L	See Sheet 3 of 3	4-15-77	21407			
	M	SEE SHEET 3 OF 3	6-17-78	21652			
	N	SEE SHEET 1 OF 3	3-25-82	21931			

NOTICE  
THE TECHNICAL MATERIEL CORP  
This drawing is issued in confidence  
to manufacture anything shown hereon  
to the user. This drawing is loaned f

QTY MODEL  
TLA

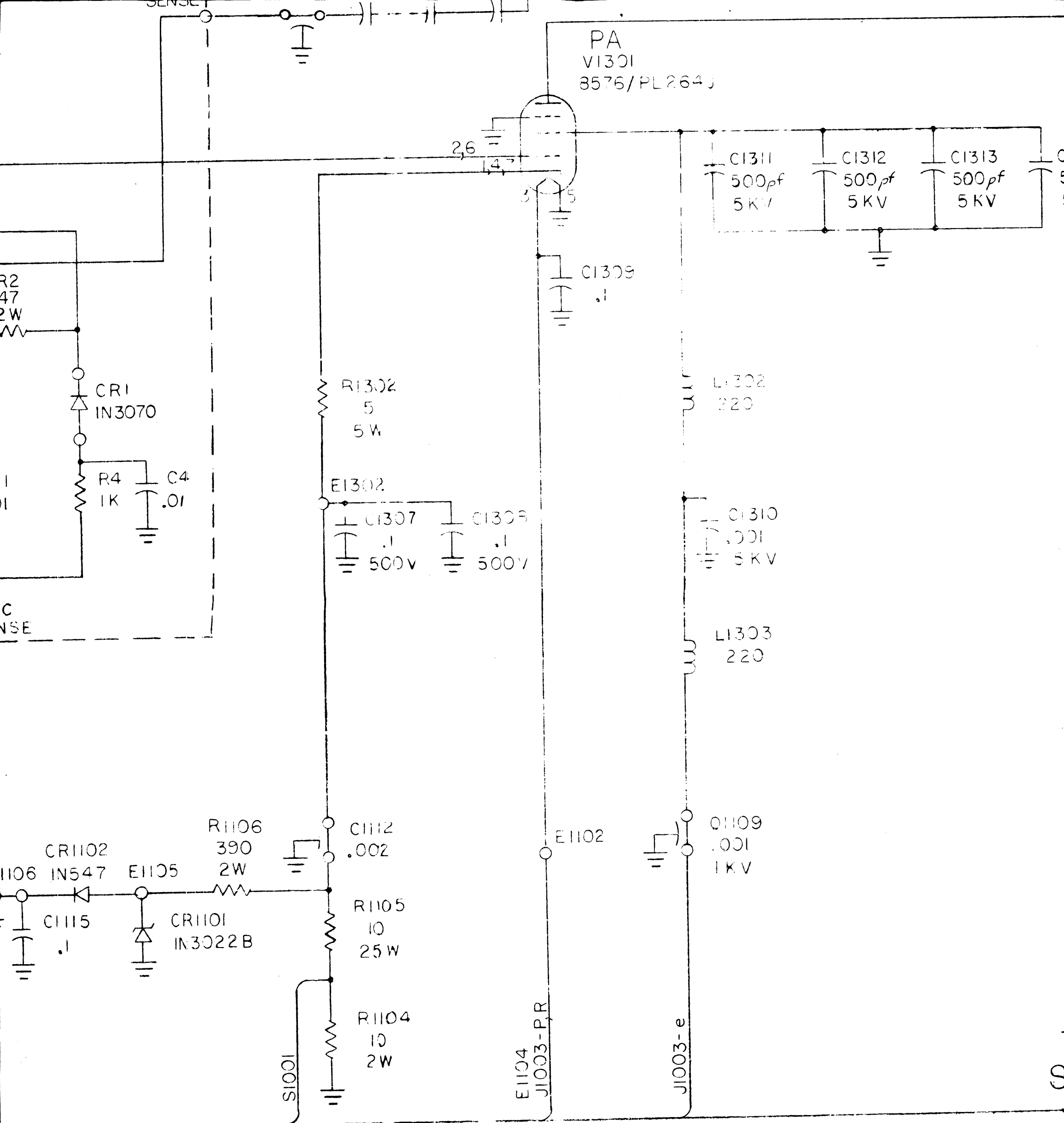

NOTICE TO PERSONS RECEIVING THIS DRAWING  
 THE TECHNICAL MATERIEL CORPORATION claims proprietary right in the material disclosed herein. This drawing is issued in confidence for engineering information only and may not be reproduced or used to manufacture anything shown hereon without permission from THE TECHNICAL MATERIEL CORPORATION to the user. This drawing is loaned for mutual assistance and is subject to recall at any time.

QTY	MODEL USED ON	ASSY
	TLAA-1K	

Schematic Diagram,  
 Power Amplifier TLAA-1K  
 (Sheet 2 of 3)



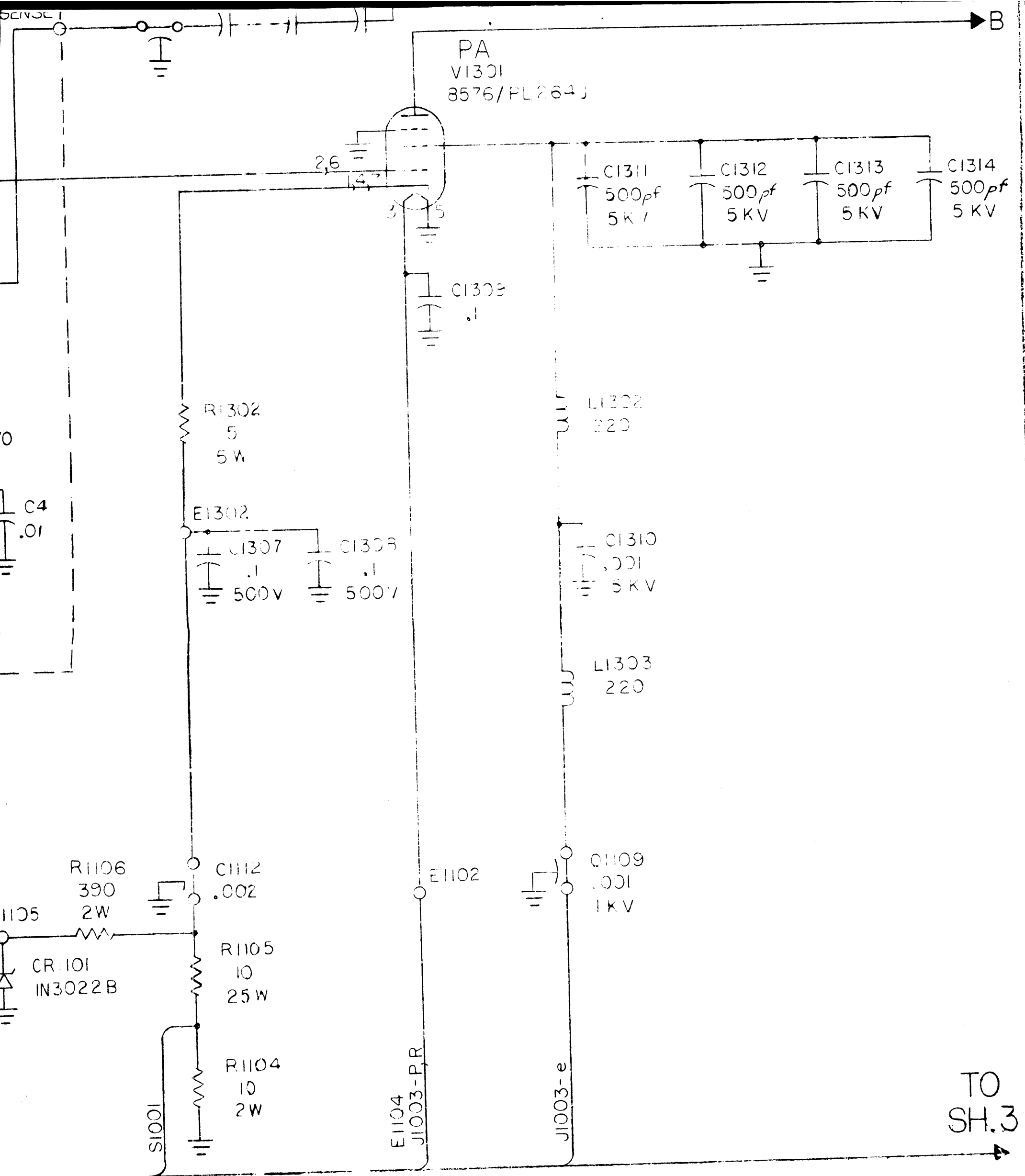

FOR THE USE OF PERSONS RECEIVING THIS DRAWING

THE CORPORATION claims proprietary right in the material disclosed herein and may not be reproduced or used for engineering information only without permission from THE TECHNICAL MATERIEL CORPORATION for mutual assistance and is subject to recall at any time.

USED ON	ASSY
AA-1K	

Schematic Diagram,  
Power Amplifier TLAA-1K  
(Sheet 2 of 3)

TO SH. 2

A1006 BAND

(AS160)

A

B

C1322  
.001  
5KV

C1323  
.001  
5KV

L1304

A1002 PA TUNE

(AY5132)

C1  
5-500 pf

L1306

L1307

L2

A1

(A4790/PC522) XA1002

P/O BI

MOT

BLK  
GRN  
RED/BLK  
RED

5

4

3

9

3

3

12

P/O BI

GEN

BRN  
BLU

5

1

S2

NC

C

NO

S1

NC

C

NO

.014

.01

.02

.01

.03

.01

C5

.04

.01

.06

.01

C7

.01

.08

.01

C10

.01

.09

.01

C12

.01

C11

.01

J1007-U

J1007-V

J1007-W

J1007-d

J1007-a

J1007-Y

J1007-X

J1007-Z

J1007-b

J1007-c

C5  
.001  
5KV

C3  
.001  
5KV

L1  
45

C1  
.001  
5KV

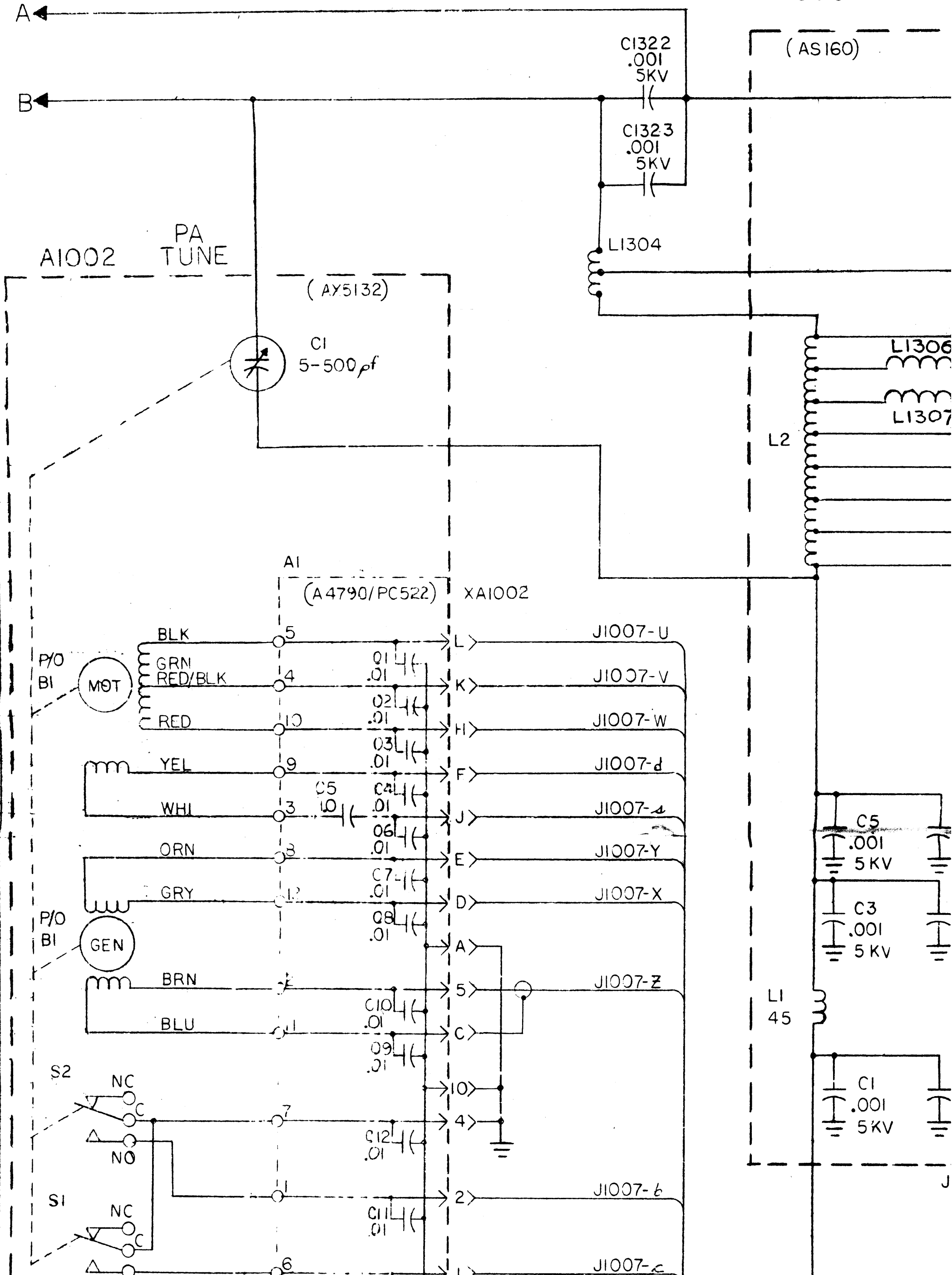

006 BANDSWITCH

(AS160)

L3

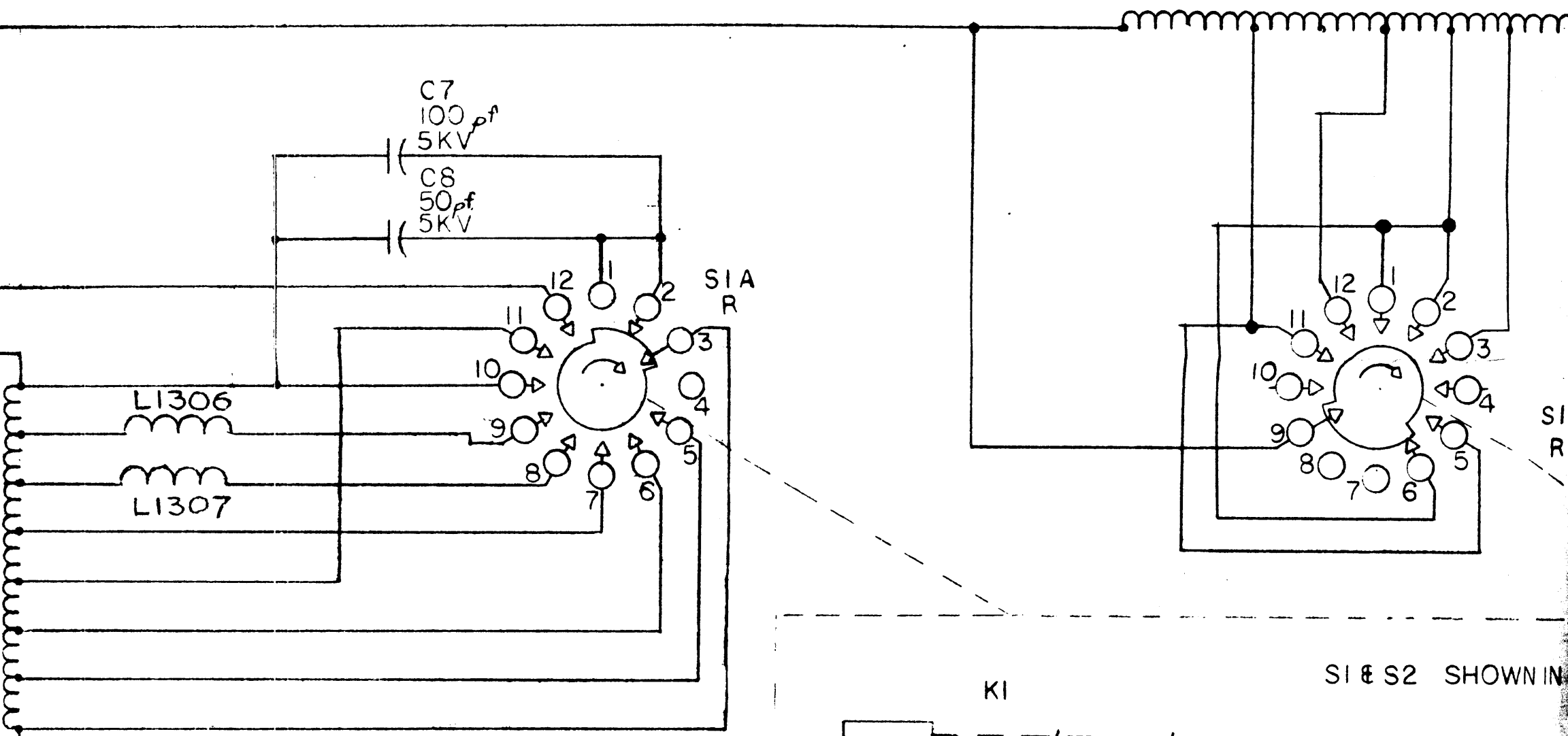

SI & S2 SHOWN IN

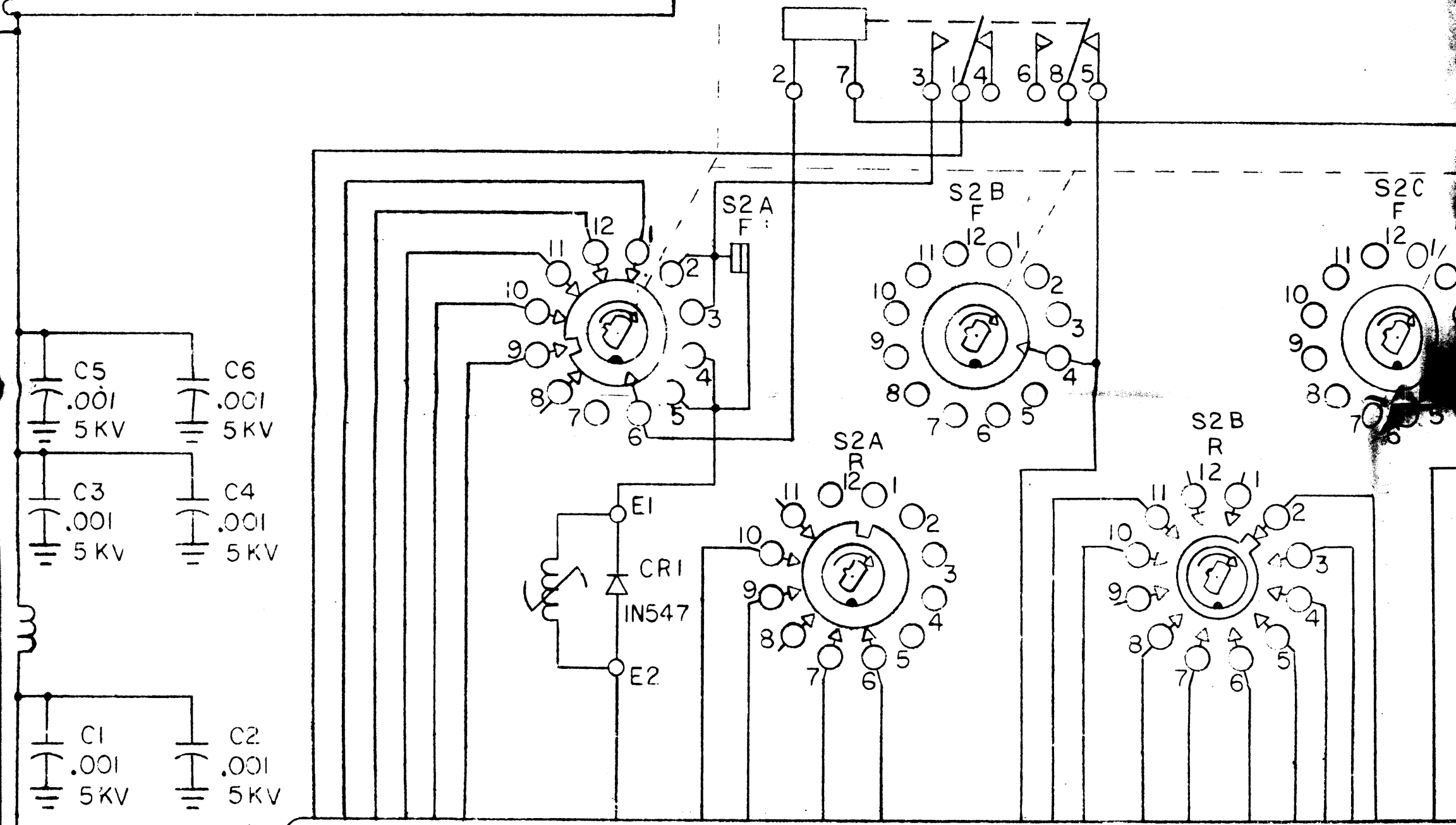

J1008

1 6 5 4 3 2 11 10 9 8 7 12 21 20 19 18 17 16 15 14 13 22

R1111  
20W

302  
A1001-K  
A1001-J  
A1001-H

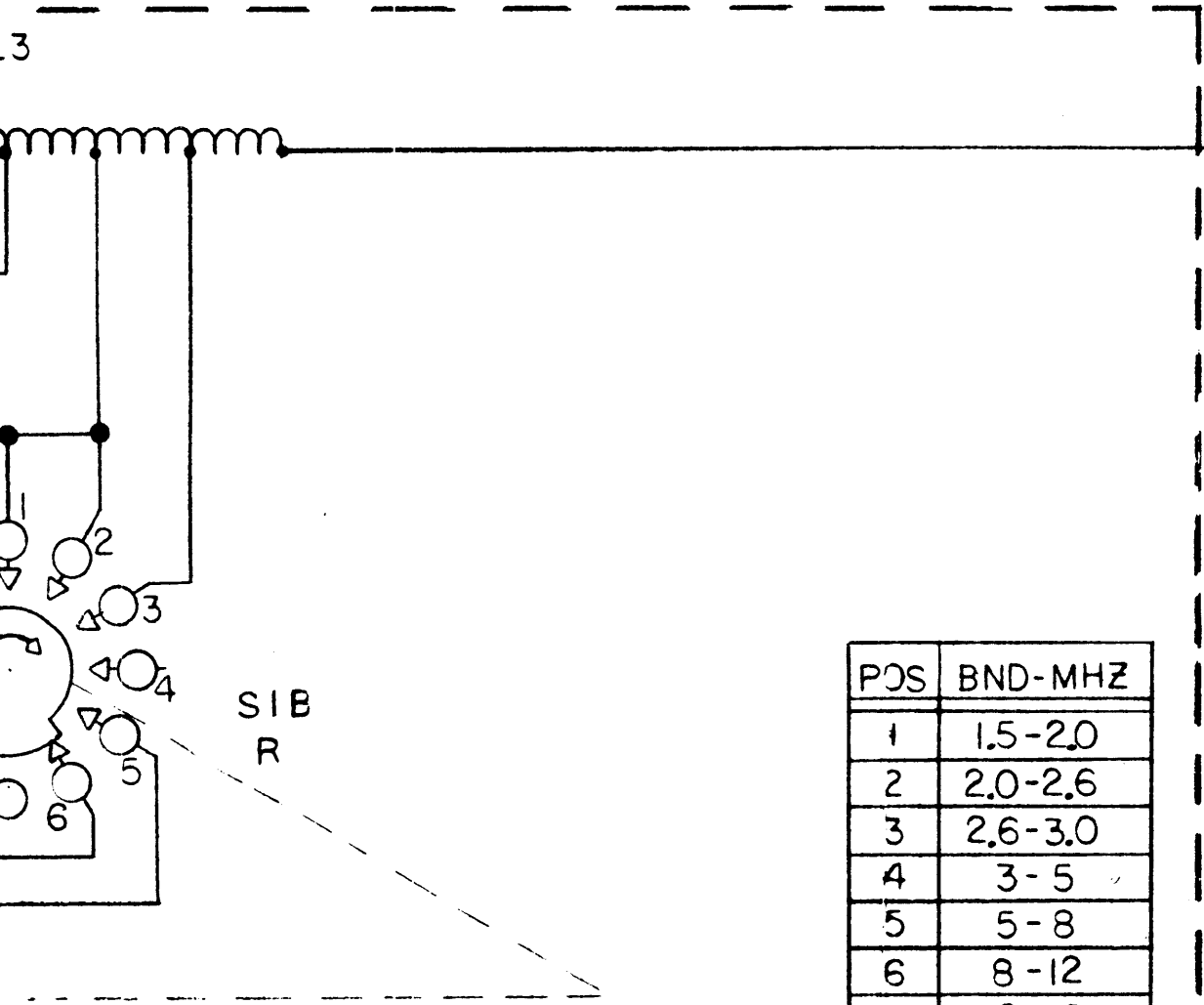

POS	BND-MHZ
1	1.5-2.0
2	2.0-2.6
3	2.6-3.0
4	3-5
5	5-8
6	8-12
7	12-16
8	*
9	16-24
10	24-30
11	*
12	*

S2 SHOWN IN POSITION 1, BAND 1.

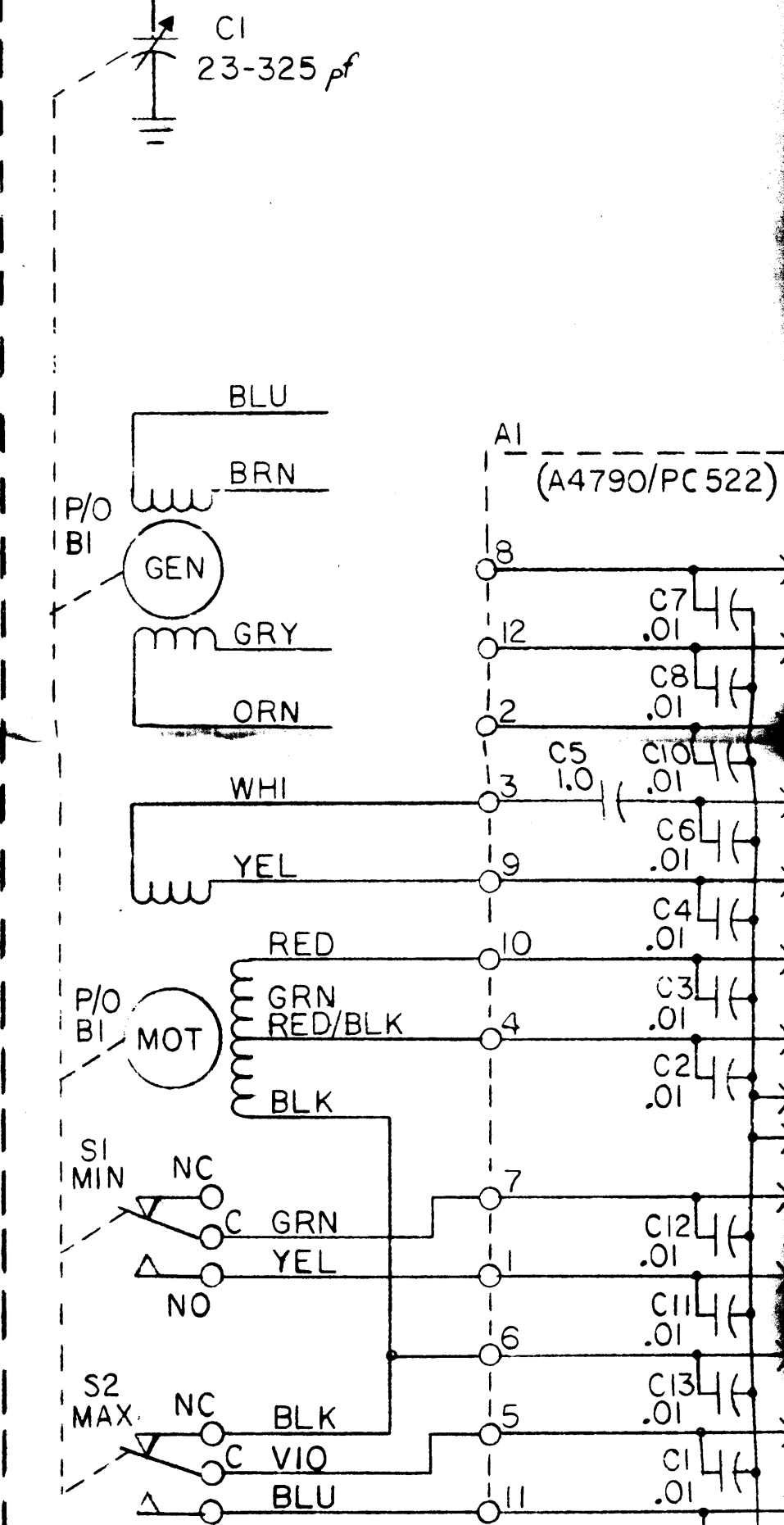
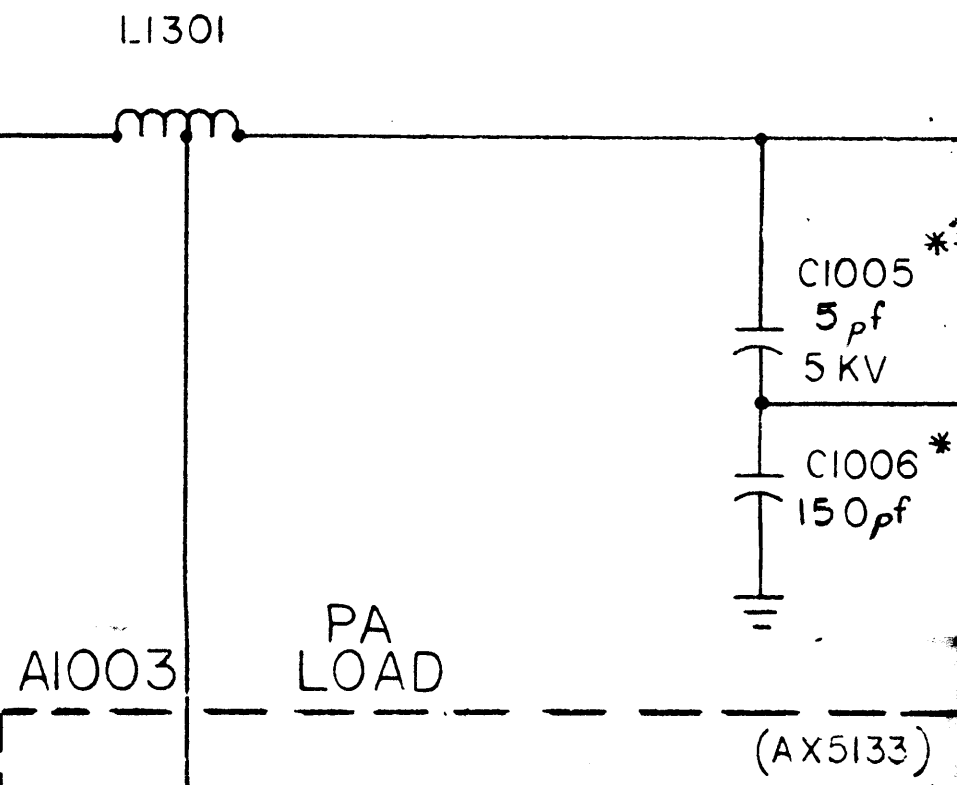
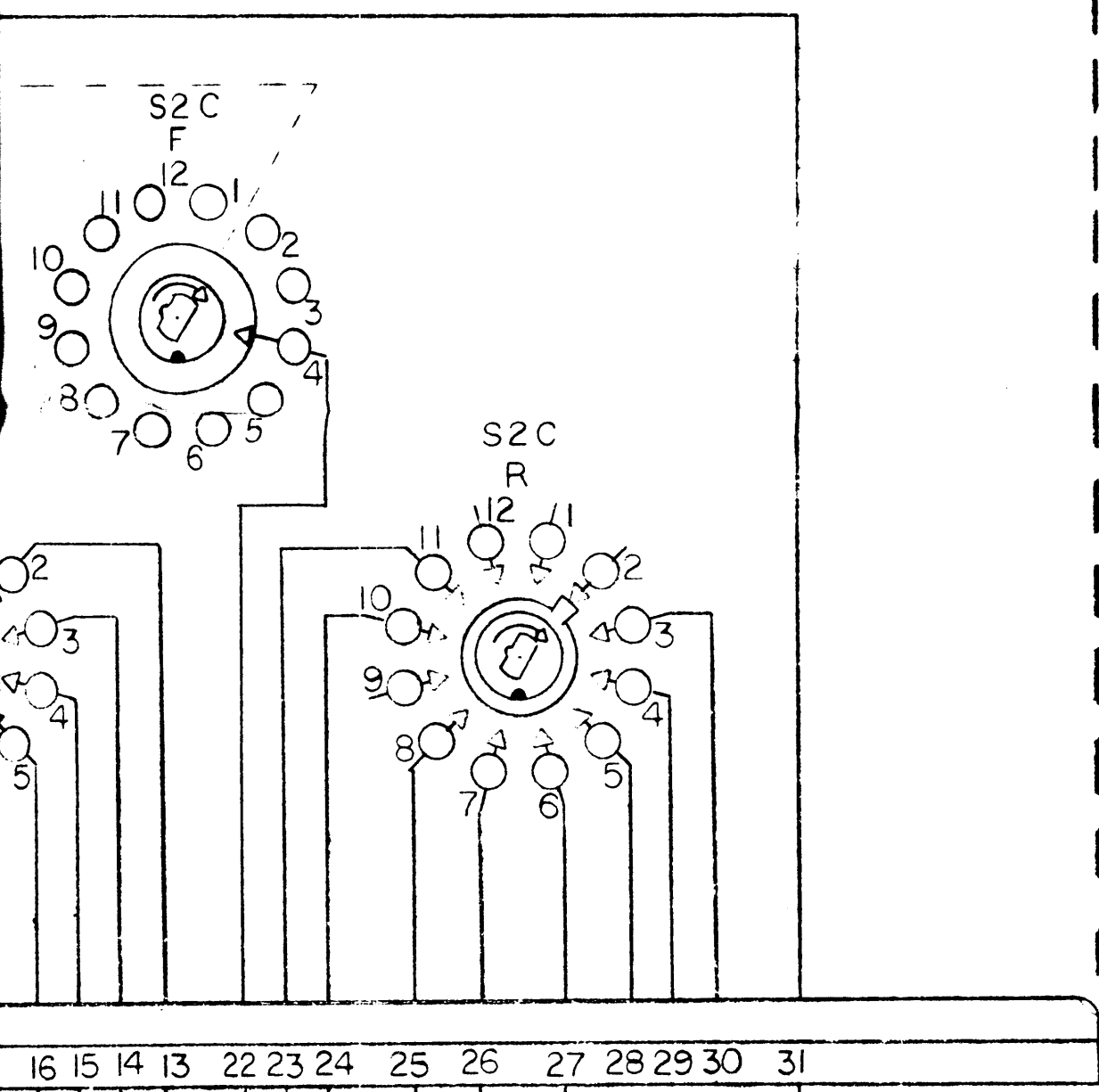

\*\*\*

A1005, C1005, C1006, DC1001 ARE MOUNTED IN THE SYSTEM IF THERE IS NO TFP-1K USED IN THE SYSTEM.

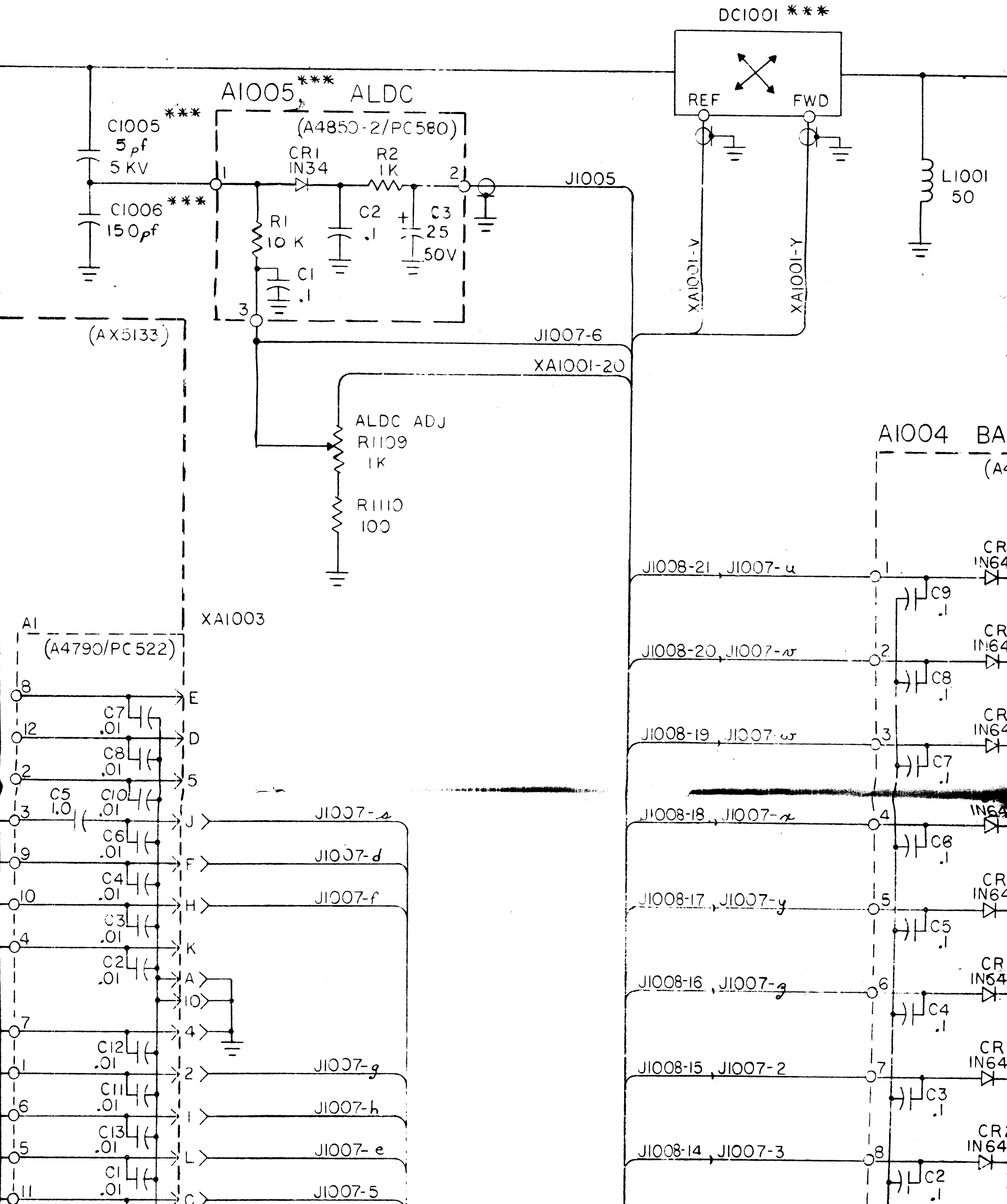

\*\*\* A1005, C1005, C1006, DC1001 ARE MOUNTED IN THE TLA IF THERE IS NO TFP-1K USED IN THE SYSTEM.

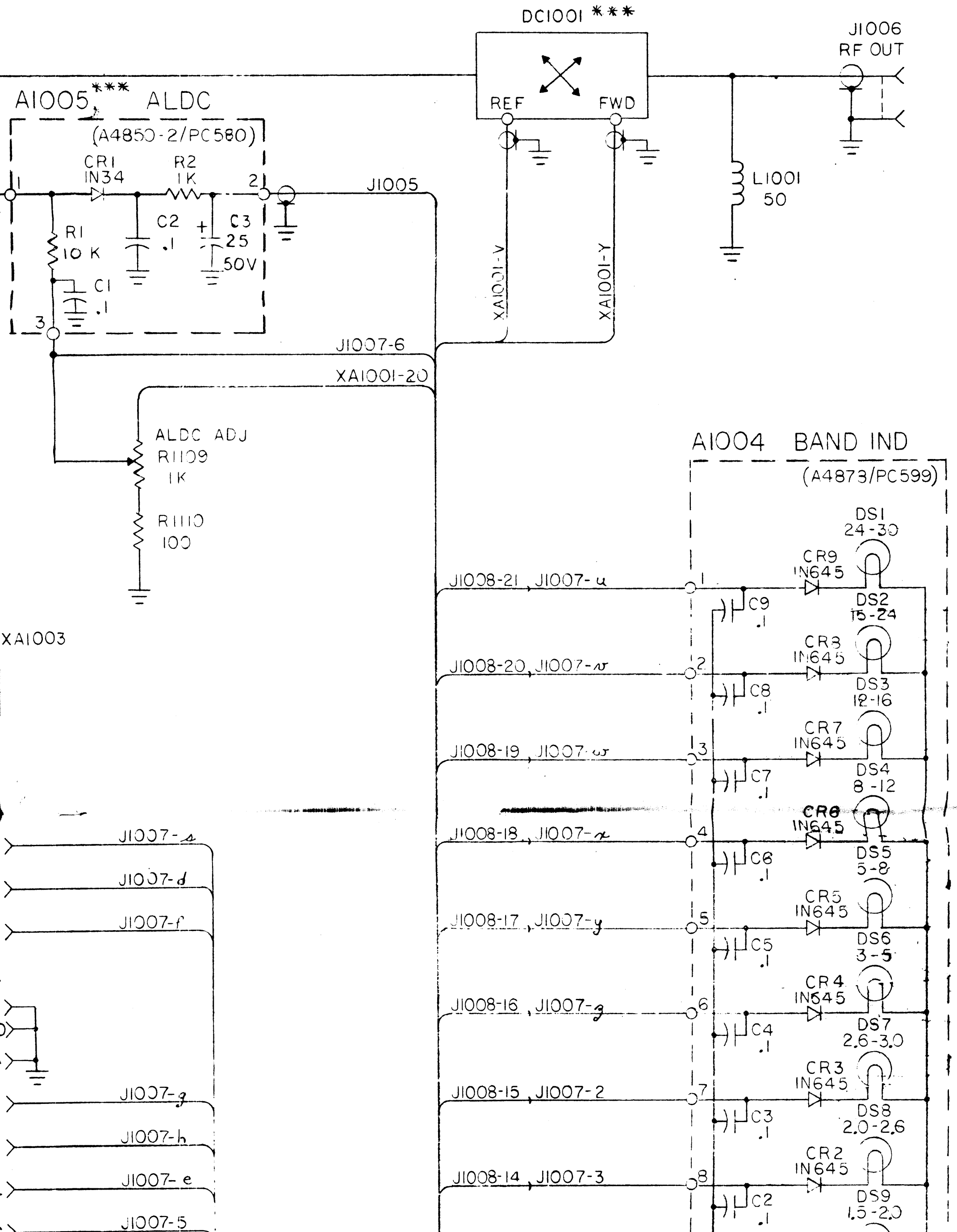

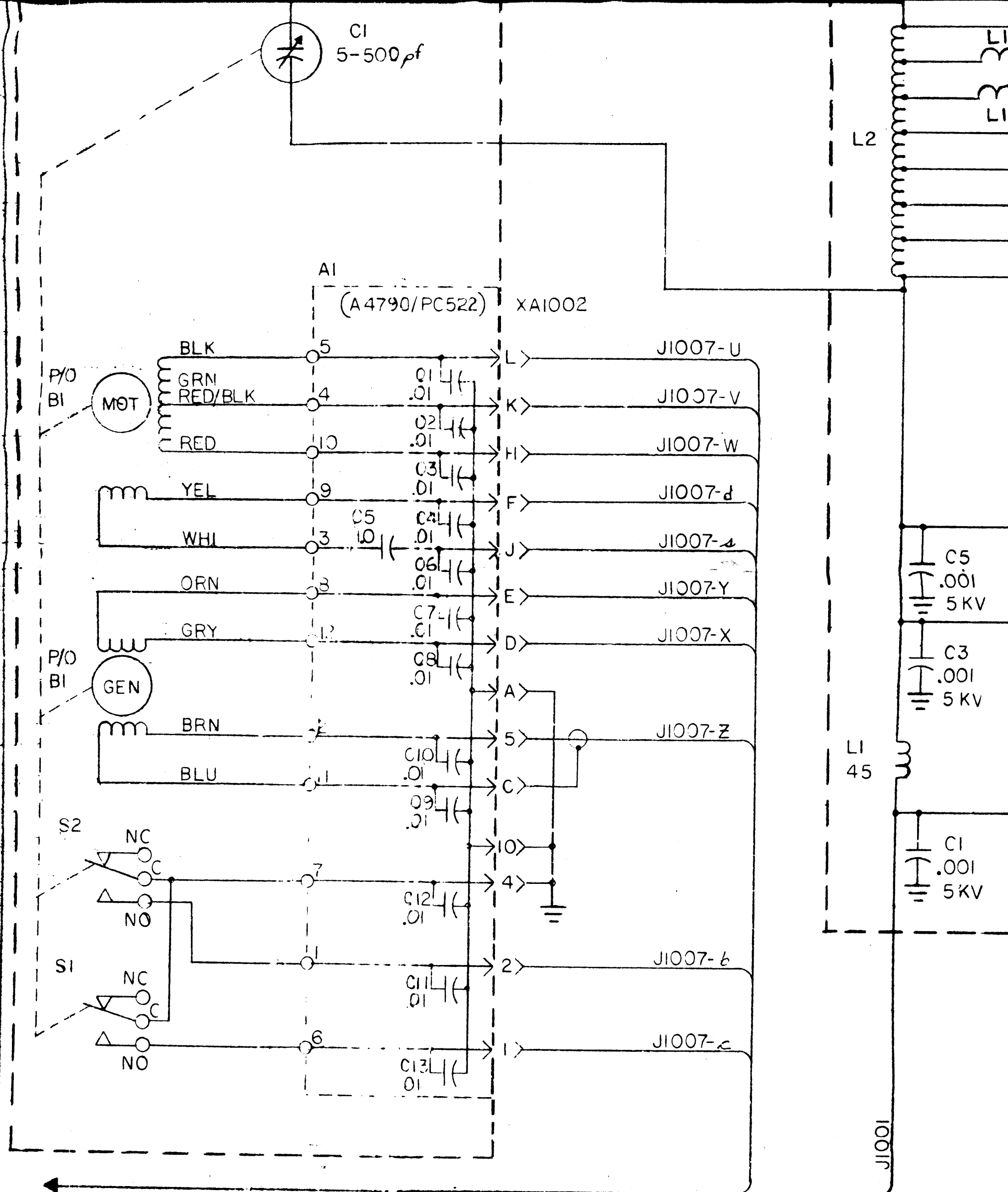

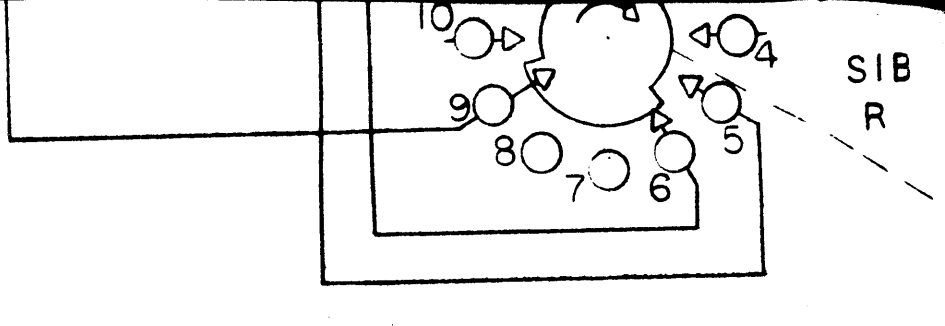
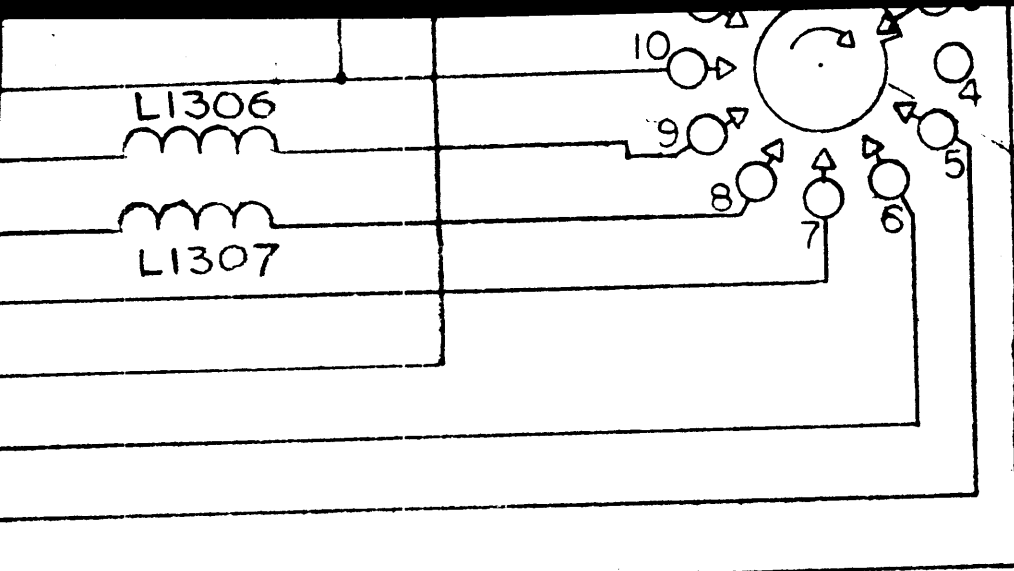

S1 & S2 SHOWN IN F

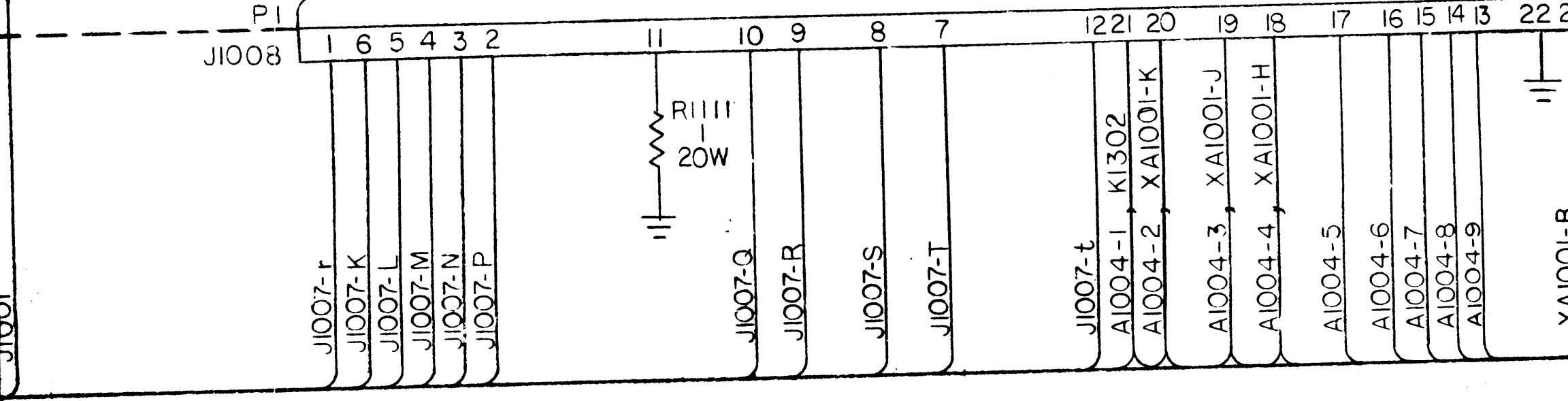
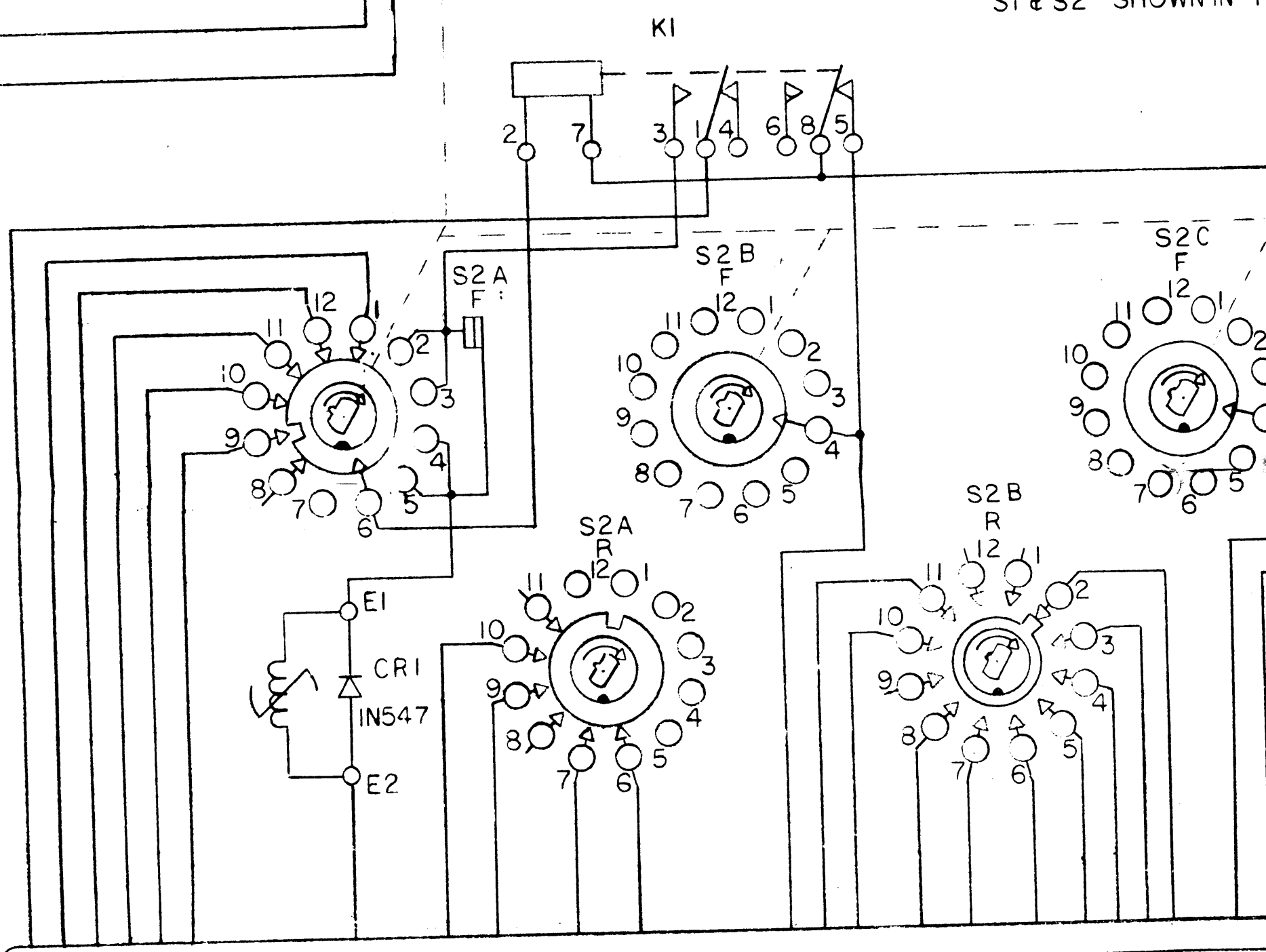
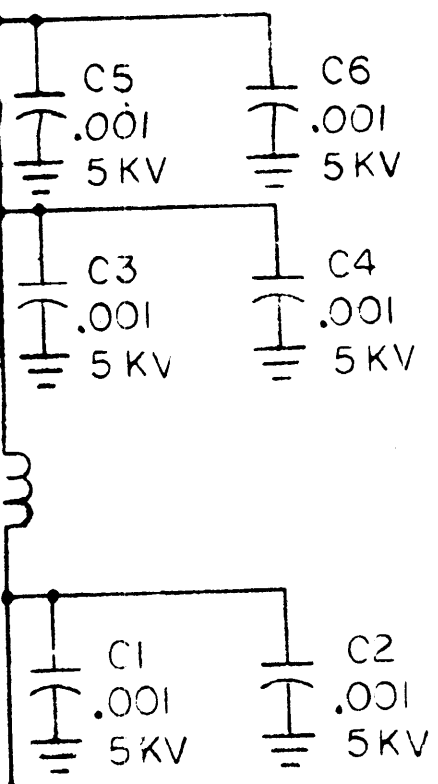



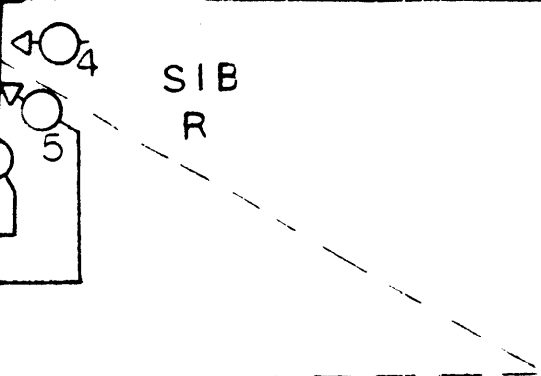

SHOWN IN POSITION 1, BAND 1.

POS	BND-MHZ
1	1.5-2.0
2	2.0-2.6
3	2.6-3.0
4	3-5
5	5-8
6	8-12
7	12-16
8	*
9	16-24
10	24-30
11	*
12	*

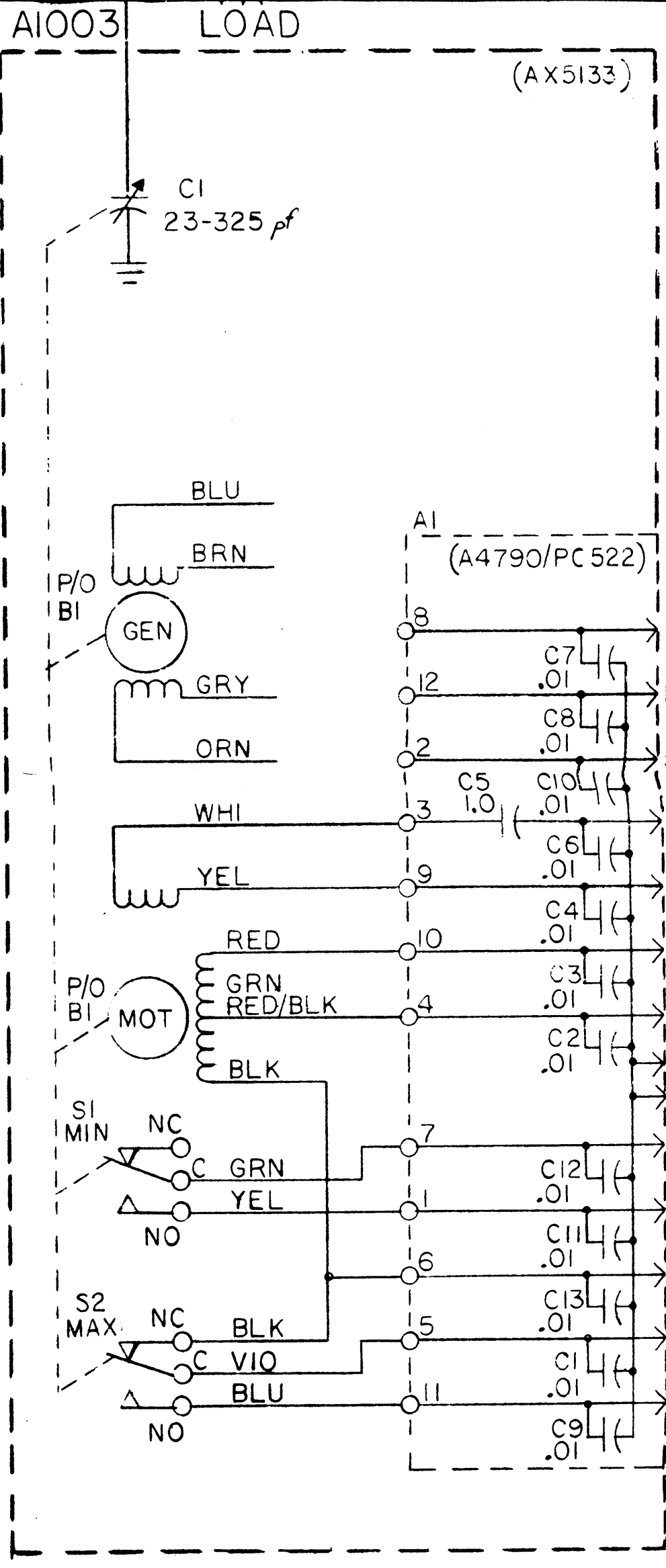
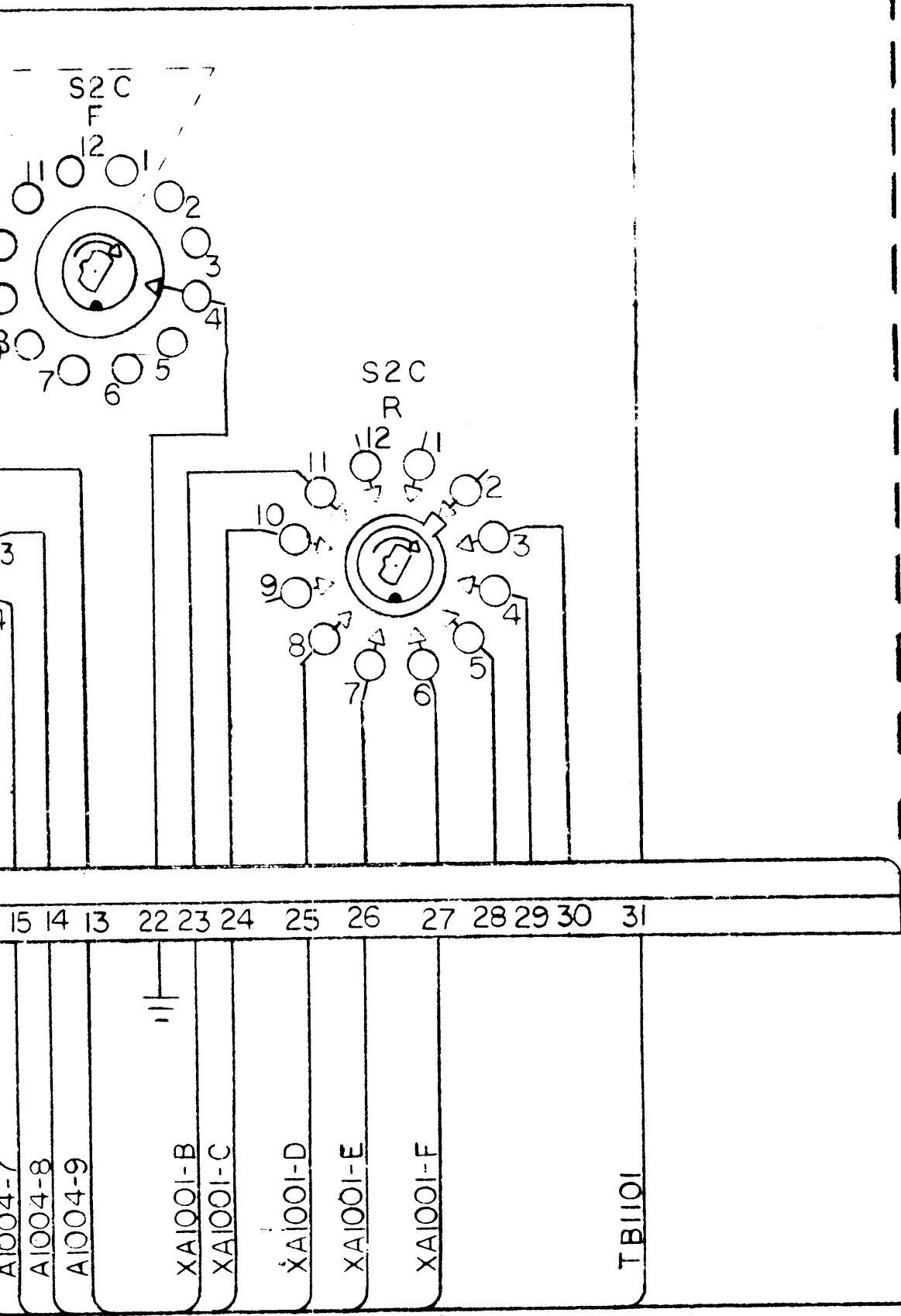

REVISIONS							
ZONE	LTR	DESCRIPTION	DATE	E.M.N.NO	DRAFT	CHKD	APPD
	X2	REVERSED A1002S1 & A1002S2	28-04-71	~			
	X	2K10 PINS FOR PPSD	18/11/71				
	A	SEE SHEET 1 & 2	11/19/71	20486			
	B	A1005C3 WAS 5/50V	2/9/72	20534			
	C	SEE SHEET 2	4/24/72	20626	GE		
	D	SEE SHEET 2	5-3-72	20671	GE		
	E	SEE SHEETS 1 & 2	10-13-72	20908	GE		
	F	SEE SHEET 2	10/30/72	20933	GE		
	G	SEE SHEET 1	11/3/71	21108	GE		
	H	SEE SHEET 2	2-11-74	21138	S.B.L.		
	K	C1005 WAS 3PF, C1006 WAS 30PF & R1 WAS 2.7K - SEE SHEETS 1 & 2	5-21-76	21415	GDL		
	L	A1001(ovw)CR5, Z1 PIN 6 Clarified	4-15-77	21407			
	M	L1306, L1307 ADD. ON S1B R COILS MODIFIED	6-17-78	21652	GDL		
	N	SEE SHEET 1 of 3	3-25-82	21931	RJ		
	P	See SHEET 1 of 3	5-6-83	22022	RAT		

THE TECHNICAL MATERIAL  
This drawing is issued in confidence to manufacture anything shown to the user. This drawing is loaned

QTY	MODE
	TL



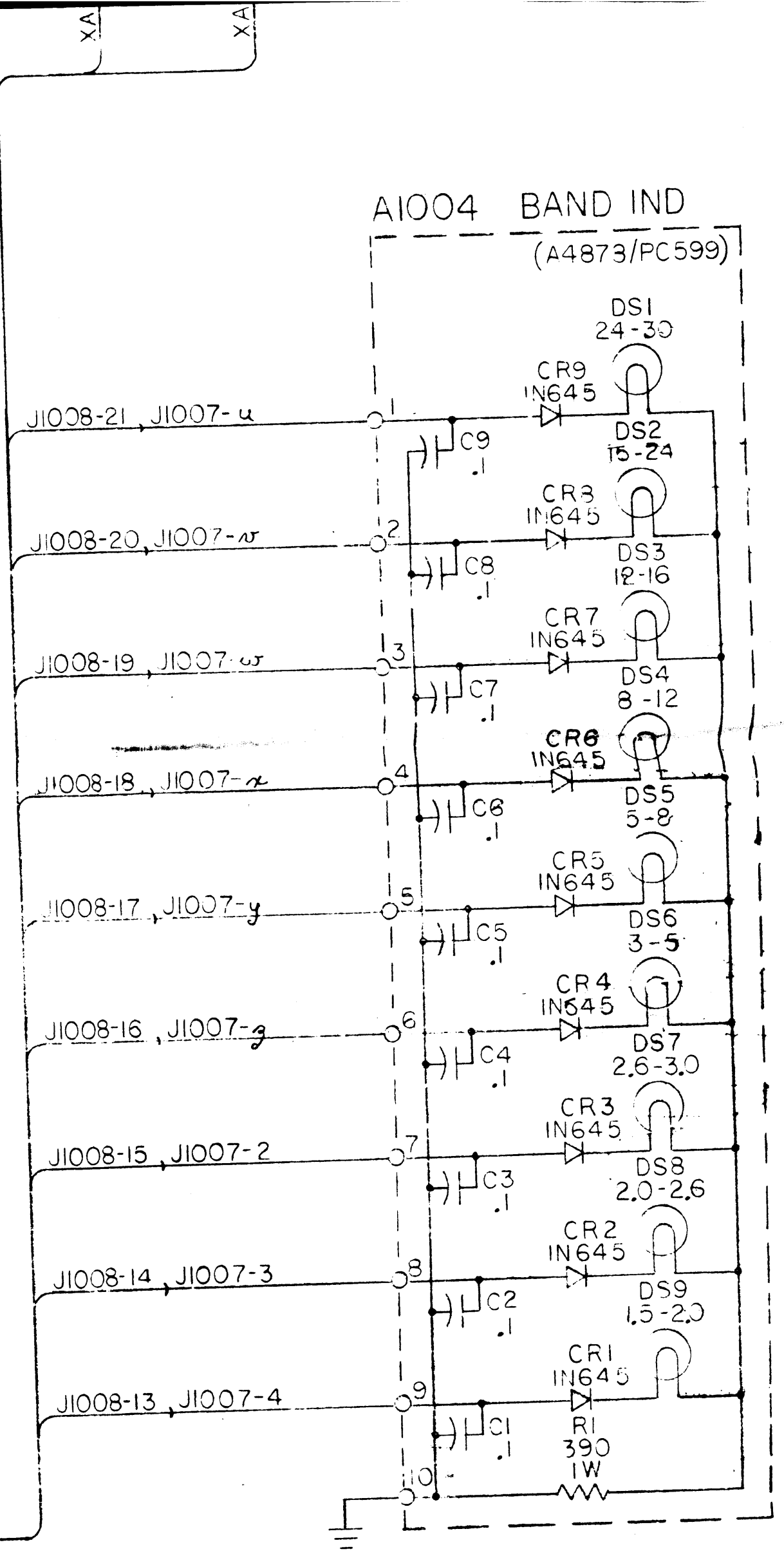
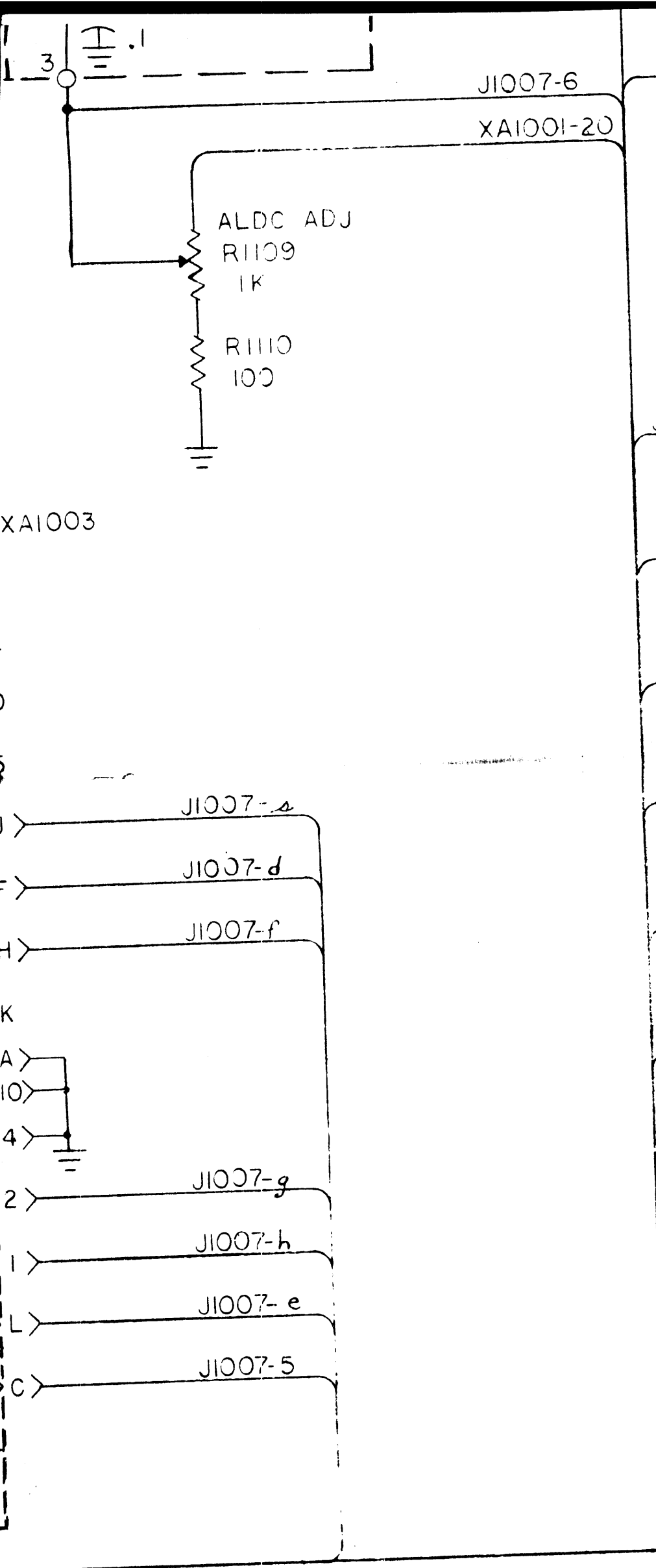

NOTICE TO PERSONS RECEIVING THIS DRAWING  
 MATERIAL CORPORATION claims proprietary right in the material disclosed hereon.  
 in confidence for engineering information only and may not be reproduced or used  
 shown hereon without permission from THE TECHNICAL MATERIEL CORPORATION  
 is loaned for mutual assistance and is subject to recall at any time

MODEL USED ON	ASS'Y
TLAA-1K	

Schematic Diagram,  
 Power Amplifier TLAA-1K  
 (Sheet 3 of 3)

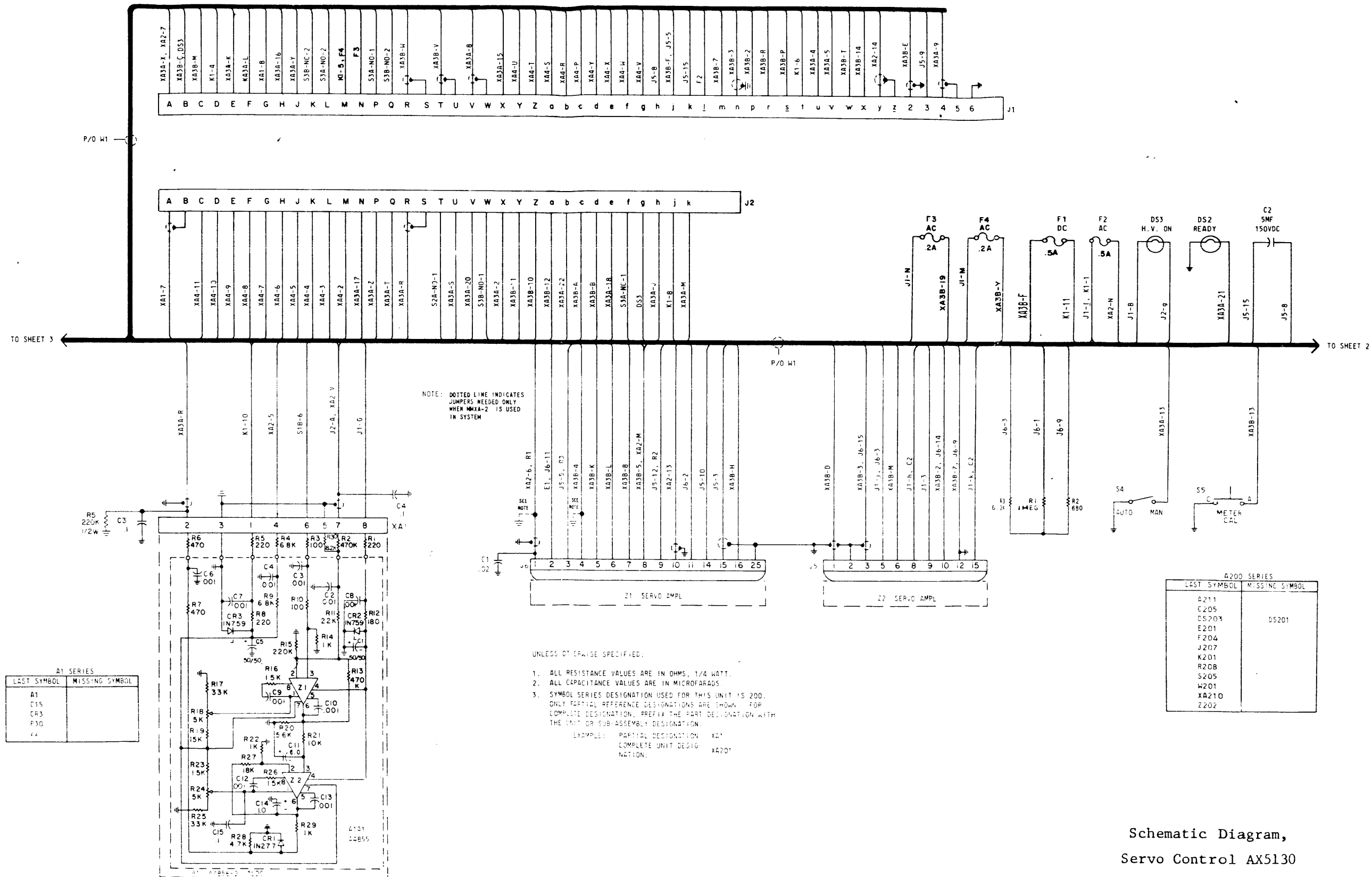

Schematic Diagram,  
Servo Control AX5130  
(Sheet 1 of 4)

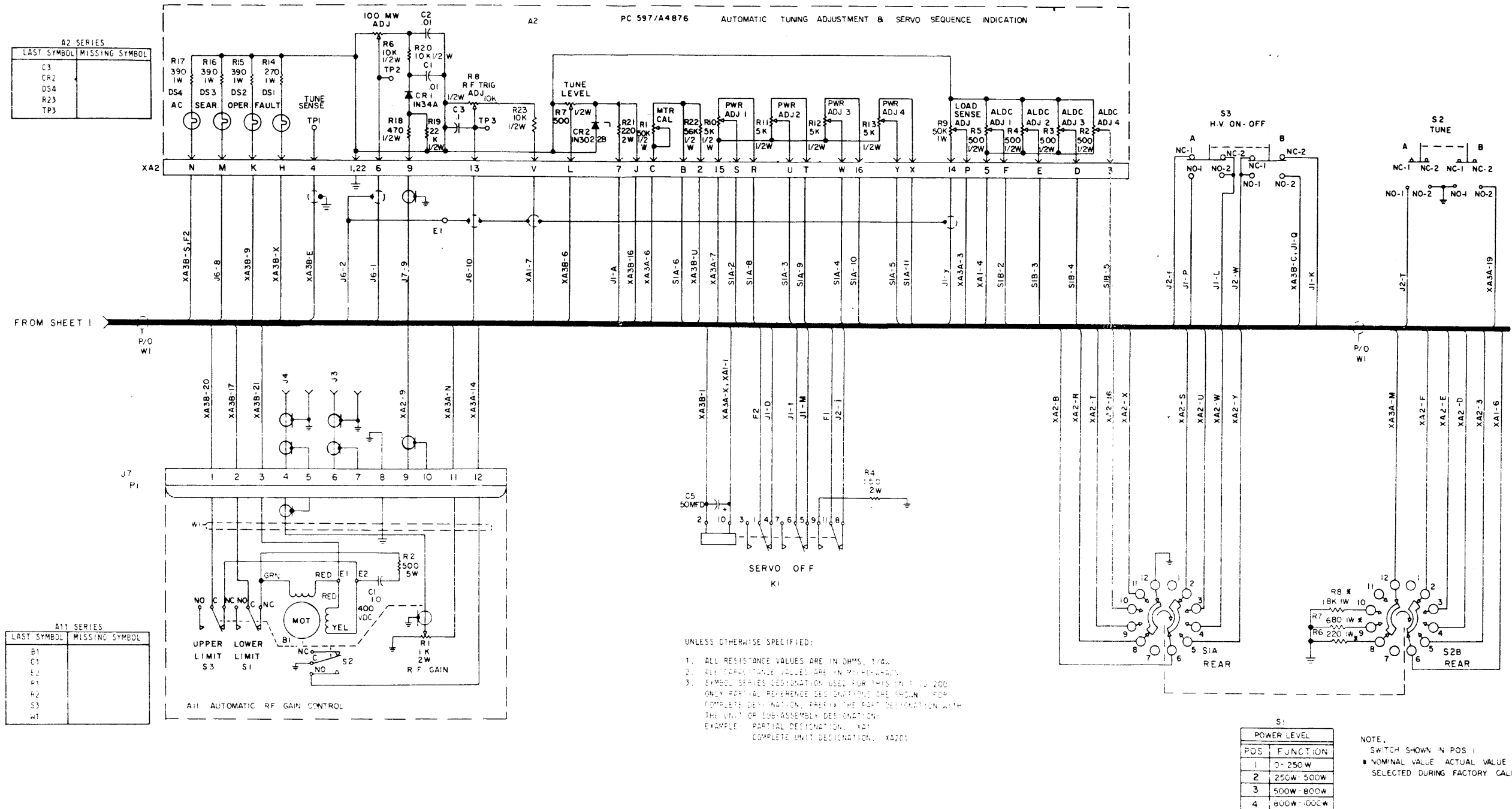

Schematic Diagram,  
Servo Control AX5130  
(Sheet 2 of 4)



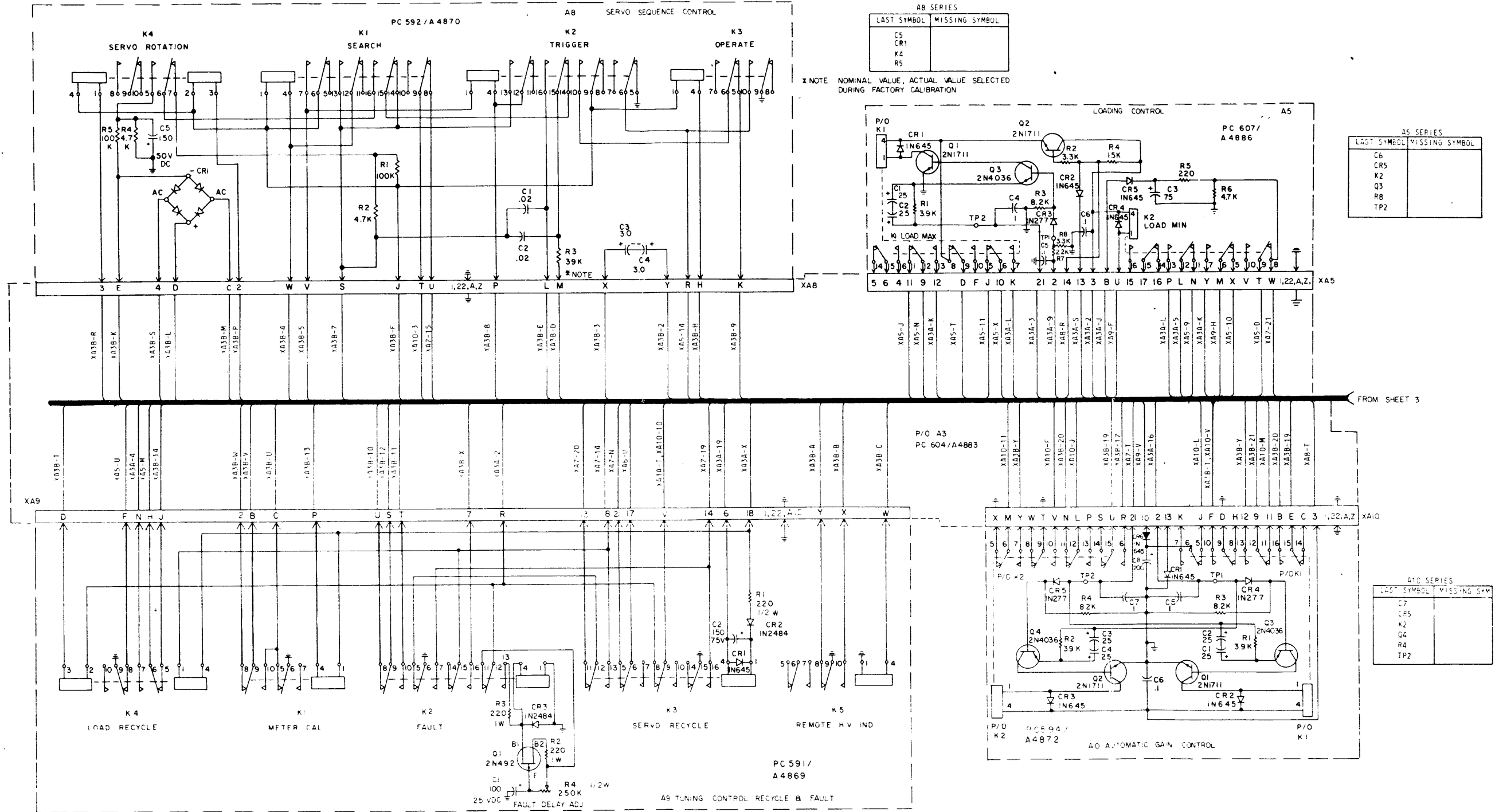

A8 SERIES

LAST SYMBOL	MISSING SYMBOL
C5	
CR1	
K4	
R5	

A5 SERIES

LAST SYMBOL	MISSING SYMBOL
C6	
CR5	
K2	
Q3	
RB	
TP2	

A10 SERIES

LAST SYMBOL	MISSING SYMBOL
C7	
CR5	
K2	
Q4	
R4	
TP2	

A9 SERIES

LAST SYMBOL	MISSING SYMBOL
CP	
CP3	
K5	
R4 Q1	

UNLESS OTHERWISE SPECIFIED:  
 1. ALL RESISTANCE VALUES ARE IN OHMS, 1/4W.  
 2. ALL CAPACITANCE VALUES ARE IN MICROFARADS.  
 3. SYMBOL SERIES DESIGNATION USED FOR THIS UNIT IS 200.  
 ONLY PARTIAL REFERENCE DESIGNATION ARE SHOWN. FOR COMPLETE DESIGNATION, PREFIX THE PART DESIGNATION WITH THE UNIT OR SUB ASSEMBLY DESIGNATION.  
 EXAMPLE: PARTIAL DESIGNATION: XA1  
 COMPLETE UNIT DESIGNATION: XA201

Schematic Diagram,  
 Servo Control AX5130  
 (Sheet 4 of 4)