

MASTER COPY
DO NOT DESTROY



TECHNICAL MANUAL

for

HARMONIC FILTER

MODEL TFP-2.5K



THE TECHNICAL MATERIEL CORPORATION
MAMARONECK, N. Y.

OTTAWA, CANADA



UNCLASSIFIED

TECHNICAL MANUAL

for

HARMONIC FILTER

MODEL TFP-2.5K



THE TECHNICAL MATERIEL CORPORATION
MAMARONECK, N.Y.

OTTAWA, ONTARIO

COPYRIGHT 1967
THE TECHNICAL MATERIEL CORPORATION

IN-9824

Issue Date: March 10, 1967

TABLE OF CONTENTS

<u>Paragraph</u>		<u>Page</u>
<u>SECTION 1-GENERAL INFORMATION</u>		
1-1.	Functional Description	1-1
1-2.	Physical Description	1-1
1-3.	Technical Specifications	1-2
<u>SECTION 2-INSTALLATION</u>		
2-1.	Unpacking and Handling	2-1
2-2.	Mechanical Installation	2-1
2-3.	Electrical Installation	2-2
<u>SECTION 3-OPERATOR'S SECTION</u>		
3-1.	Operating Instructions	3-1
<u>SECTION 4-PRINCIPLES OF OPERATION</u>		
4-1.	General	4-1
4-2.	Circuit Analysis	4-3
<u>SECTION 5-MAINTENANCE</u>		
5-1.	Preventive Maintenance	5-1
5-2.	Troubleshooting	5-2
5-3.	Repair and Replacement	5-7
<u>SECTION 6-PARTS LIST</u>		
6-1.	Introduction	6-1
<u>SECTION 7-SCHEMATIC DIAGRAMS</u>		

LIST OF ILLUSTRATIONS

<u>Figure</u>		<u>Page</u>
<u>SECTION 1-GENERAL INFORMATION</u>		
1-1.	Harmonic Filter, Model TFP-2.5K	1-0
<u>SECTION 2-INSTALLATION</u>		
2-1.	Tilt-Lock Slide Mechanism Details	2-2
2-2.	Typical Interconnection Diagram	2-3
<u>SECTION 3-OPERATOR'S SECTION</u>		
3-1.	Front Panel Control	3-1
<u>SECTION 4-PRINCIPLES OF OPERATION</u>		
4-1.	Simplified Block Diagram	4-2
<u>SECTION 5-MAINTENANCE</u>		
5-1.	Switch Assembly, AX664	5-6
5-2.	Bottom Chassis Component Layout	5-8
<u>SECTION 7-SCHEMATIC DIAGRAMS</u>		
7-1.	Schematic Diagram, TFP-2.5K	7-2/7-3

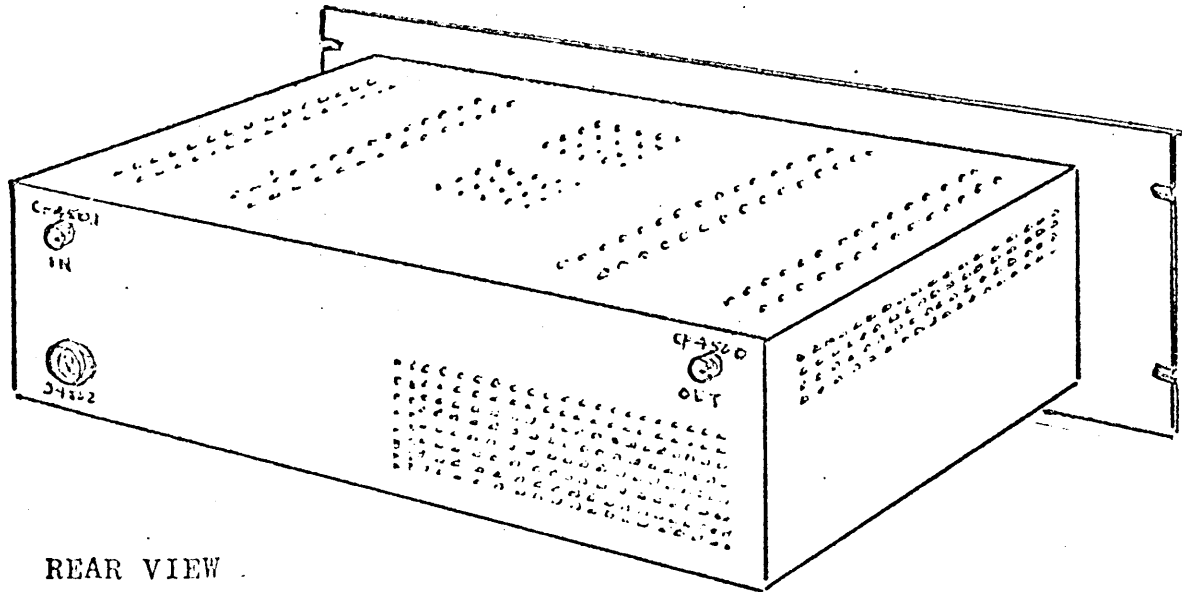

REAR VIEW

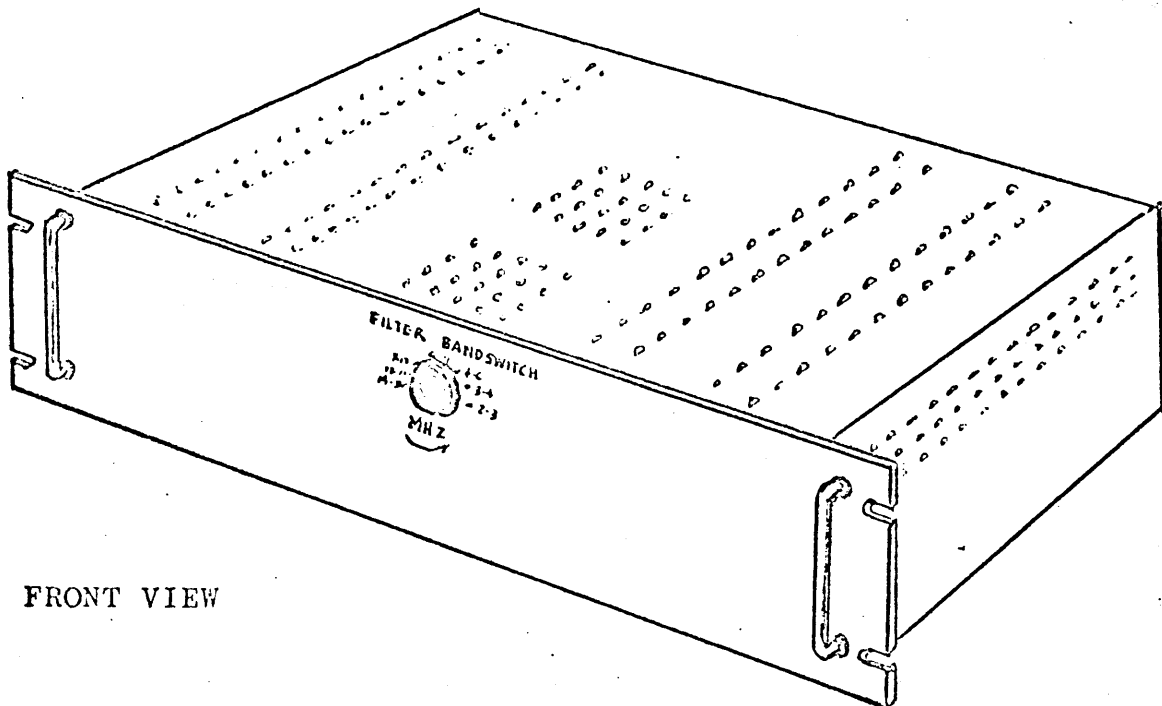

FRONT VIEW

Figure 1-1. Harmonic Filter, Model TFP-2.5K

SECTION I

GENERAL INFORMATION

1-1. FUNCTIONAL DESCRIPTION

Harmonic Filter, Model TFP-2.5K (figure 1-1) is a selectable harmonic filter unit, designed to operate in conjunction with a transmitter operating in the 2 to 30 megacycle (MHz) frequency range.

The TFP is functionally an in/out filter configuration. The transmitter operating frequency is routed through a frequency corresponding harmonic filter network, the output of which is harmonically suppressed to meet FCC harmonic suppression requirements.

Harmonic filtering in the 2 to 19 mc (MHz) frequency range is accomplished by six harmonic filter networks in the TFP; the 19 to 30 mc frequency range harmonic filter network is an externally located unit (AF107), normally mounted on the inside-rear of the equipment rack.

1-2. PHYSICAL DESCRIPTION

The TFP is equipped with a 19-inches wide front panel, suitable for mounting into any standard width equipment rack or console.

The unit measures 7-inches high supporting a 17-inches deep chassis.

The front panel displays one control; a seven-position FILTER BANDSWITCH rotary selector switch. The rear chassis contains three connectors; an r-f input connector CP4501, an r-f output connector CP4500, and a control-input cable connector J4502.

1-3. TECHNICAL SPECIFICATIONS

Harmonic Filter Range:

2 to 30 mc (MHz) in seven
selectable positions:
2-3 mc (AF106-1)
3-4 mc (AF106-2)
4-6 mc (AF106-3)
6-9 mc (AF106-4)
9-13 mc (AF106-5)
13-19 mc (AF106-6)
19-30 mc (AF107, externally located)

Dimensions:

19-inches wide X 7-inches
high X 17-inches deep.

Power Requirements:

-24 vdc from an external source
for relay and stepping switch
operation.

SECTION 2 INSTALLATION

2-1. UNPACKING AND HANDLING

The TFP is tested at the factory and is carefully packaged to prevent damage during shipment. Upon receipt of the equipment, inspect the packing case and its contents for damage that might have occurred during transit. Unpack the equipment carefully and inspect all packing material for parts that may have been shipped as loose items. With respect to damage to the equipment for which the carrier is liable, The Technical Materiel Corporation will assist in describing methods of repair and the furnishing of replacement parts.

2-2. MECHANICAL INSTALLATION

The TFP is equipped with a standard 19-inch wide front panel and is designed for installation in an equipment cabinet. Refer to figure 2-1 and install the unit in the rack as follows:

a. Pull out center sections of tracks, located in the equipment rack, until they lock in extended position.

b. Position slide mechanisms of TFP in tracks, and ease unit into rack until release fingers engage holes in tracks.

c. Depress release fingers and slide unit completely into rack.

NOTE

To prevent the cables from snagging, attach cable retractors (located inside the rack) to the cables before sliding the unit into the rack.

d. Make necessary cable and electrical connections as described in paragraph 2-3.

e. Secure front panel of TFP to rack with screws and washers.

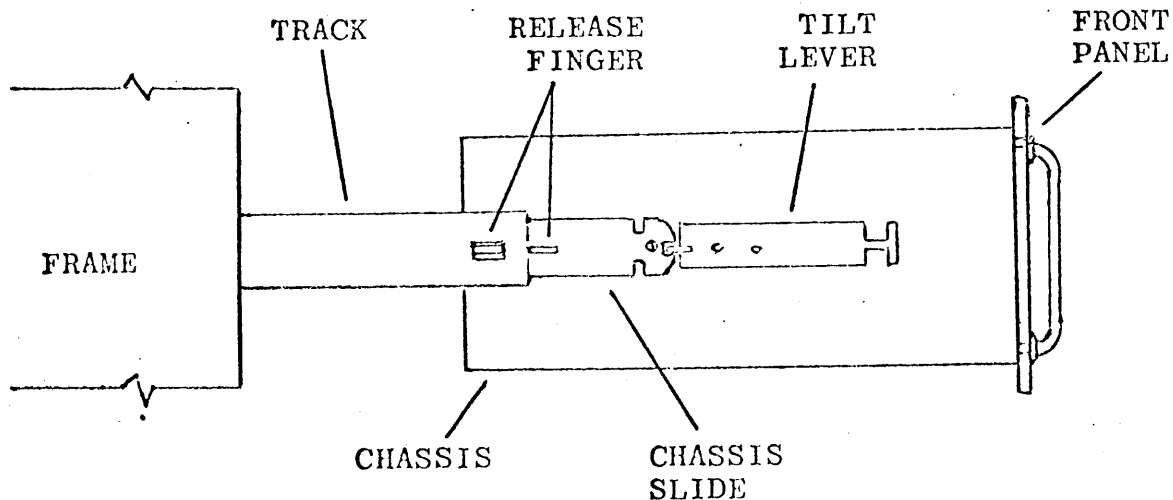

Figure 2-1. Tilt-Lock Slide Mechanism Details

2-3. ELECTRICAL INSTALLATION

a. POWER REQUIREMENTS - The TFP operates from voltages received from the associated transmitter system, -24 vdc for relay and stepping switch solenoid operation.

b. INTERCONNECTIONS - Refer to the interconnect cabling diagram provided in the associated system manual and make the cabling connections between the TFP and related units as indicated. All connections to the TFP are made at the rear panel.

See figure 2-2 for a typical interconnection diagram of the TFP in relation to a typical transmitter system configuration.

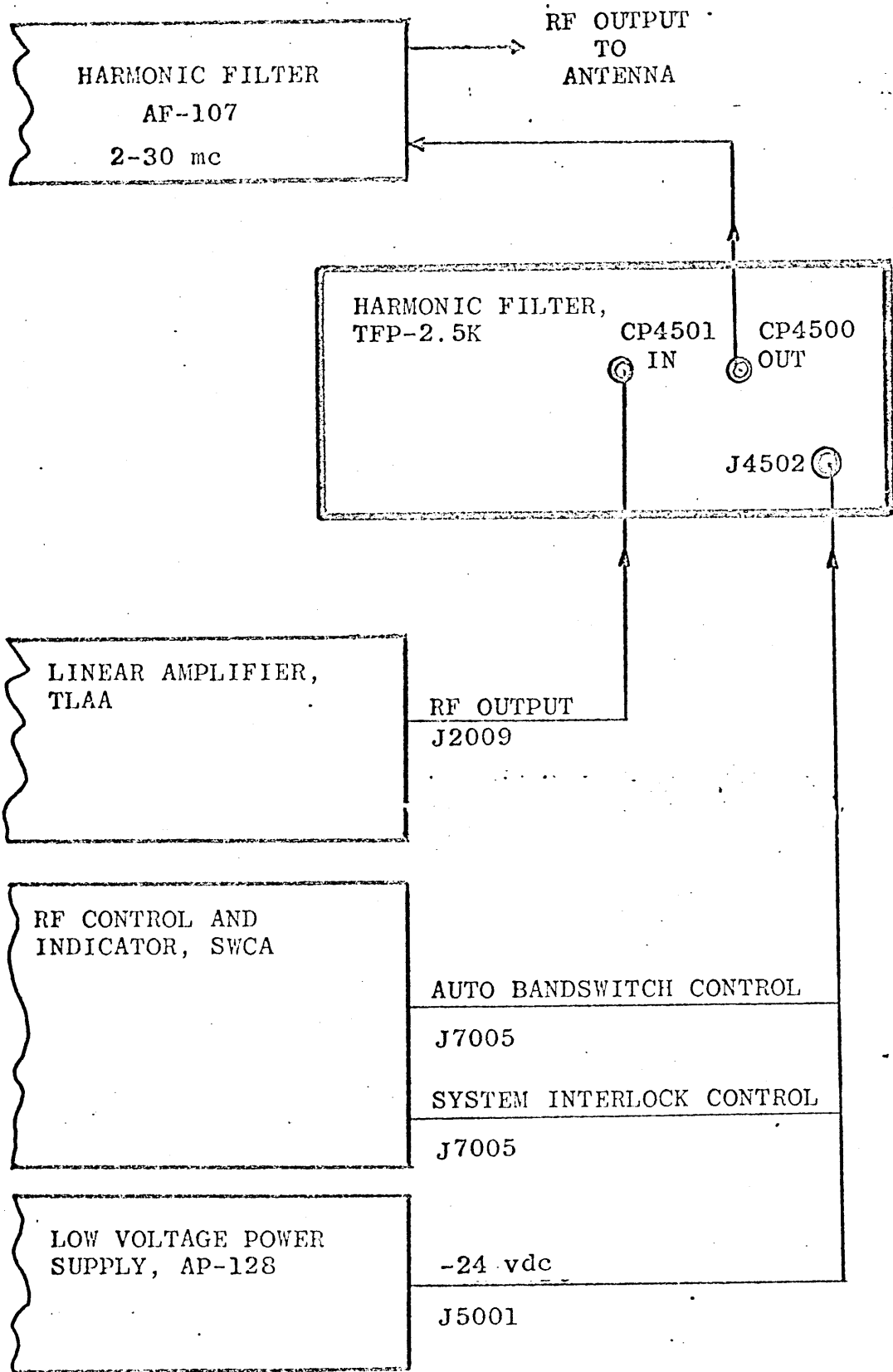

Figure 2-2. Typical Interconnection Diagram

SECTION 3

OPERATOR'S SECTION

3-1. OPERATING INSTRUCTIONS

The TFP contains one operating control: a front panel mounted, seven-position FILTER BANDSWITCH rotary solenoid switch. The 2 to 30 mc frequency range is covered in seven positions: 2-3 mc, 3-4 mc, 4-6 mc, 6-9 mc, 9-13 mc, 13-19 mc and 19-30 mc. See figure 3-1.

The FILTER BANDSWITCH control is used to select the appropriate harmonic filter network corresponding to the transmitter operating frequency. Selection may be made either manually or automatically

Manual selection is accomplished by manually setting the FILTER BANDSWITCH control to the same frequency band setting as that of the transmitter's frequency bandswitch control. Should the FILTER BANDSWITCH be mistakenly set to the improper filter network setting, the transmitter will react to an open-interlock condition

Automatic selection is accomplished by a positioning signal, initiated by the transmitter's frequency bandswitch control, automatically positioning the FILTER BANDSWITCH control to the proper setting.

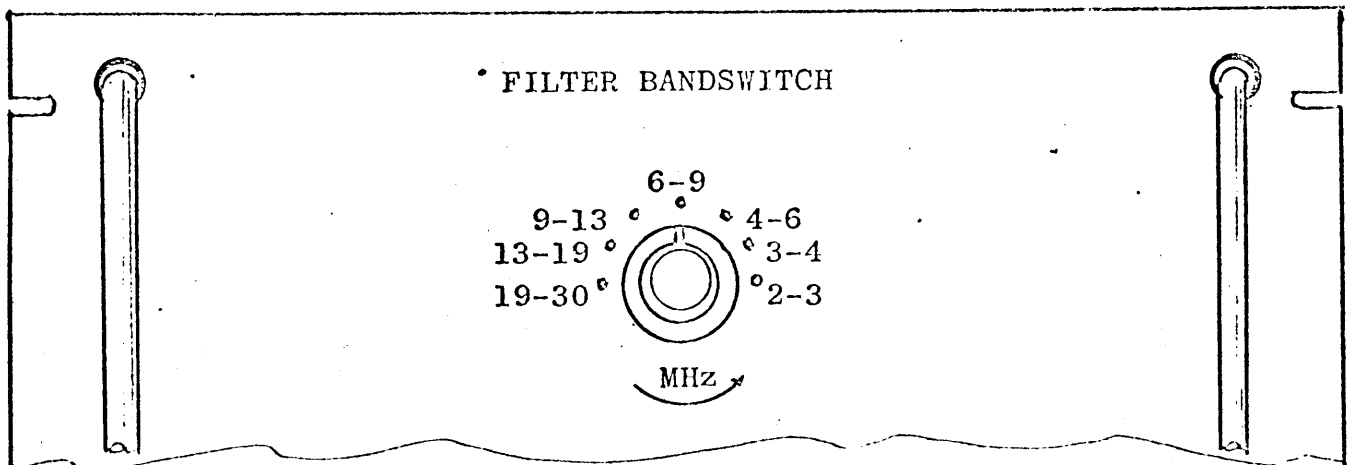

Figure 3-1. Front Panel Control

SECTION 4

PRINCIPLES OF OPERATION

4-1. GENERAL

The TFP is functionally an in/out filter configuration. The selected transmit frequency, in the 2 to 30 mc range, is applied at the input of the TFP, routed through a corresponding frequency harmonic filter network, and out to the transmitter system's antenna directional coupler.

The TFP is configured to cover the 2 to 30 mc frequency range in seven separate harmonic filter networks. These seven filter networks (2-3 mc, 3-4 mc, 4-6 mc, 6-9 mc, 9-13 mc, 13-19 mc and 19-30 mc) are selected by the front panel mounted FILTER BANDSWITCH control. The FILTER BANDSWITCH control is a seven-position, solenoid-controlled rotary stepping switch, receiving the proper filter frequency positioning control voltages from the transmitter system's r-f control and indicator unit. The FILTER BANDSWITCH control, being slave-controlled by the transmitter, is automatically set to the proper harmonic filter setting corresponding to the selected transmit operating frequency.

The FILTER BANDSWITCH may also be set to the desired setting manually. However, to ensure that the FILTER BANDSWITCH control is set at the proper position, corresponding to the selected transmit operating frequency, a safety interlock system is employed. If the FILTER BANDSWITCH is incorrectly positioned, the transmitter will not operate.

See figure 4-1 for a simplified block diagram.

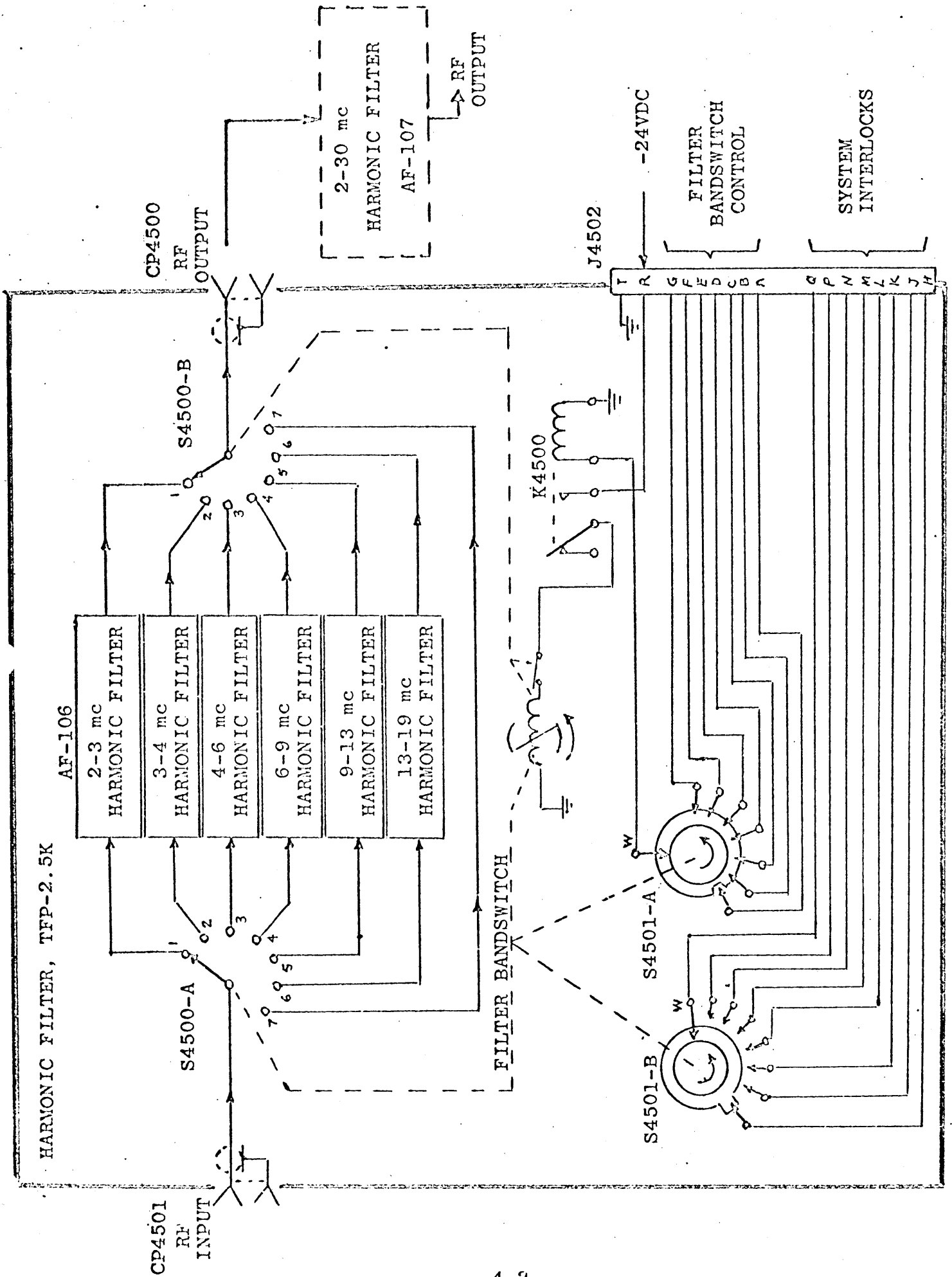

Figure 4-1. Simplified Block Diagram

4-2. CIRCUIT ANALYSIS

The selected transmit frequency r-f output, from the transmitter system's linear amplifier section, is applied to the wiper of the VILTER BANDSWITCH control (S4500-A) via r-f input connector CP4501. The FILTER BANDSWITCH control, set either manually or automatically to the correct filter position corresponding to the selected transmit frequency range, routes the r-f through a harmonic filter network (AF106).

The filtered output, harmonically suppressed, is then routed, through an externally mounted 2 to 30 mc harmonic filter (AF107) to the transmitter system's antenna. This final harmonic filter network (AF107) is employed for all operating frequencies and acts as the seventh harmonic filter network for the FILTER BANDSWITCH 19-30 mc position.

Automatic FILTER BANDSWITCH positioning is accomplished by a control voltage, initiated in the transmitter system's r-f control and indicator unit, acting upon the stepping switch solenoid of the FILTER BANDSWITCH control.

This is achieved by a voltage potential, initiated at the transmitter system's r-f control and indicator unit, routed to a particular switch position of S4500-A. This voltage, appearing at a position corresponding to the transmitter system's operating frequency band, is routed through the wiper of S4500-A to the solenoid of relay K4500.

Energizing relay K4500 in turn closes a set of normally open contacts. The closed contacts of relay K4500 then route a -24 vdc potential, from the system's power supply, to the FILTER BANDSWITCH

stepping switch solenoid. The stepping switch solenoid will then rotate the FILTER BANDSWITCH control until it reaches the pre-determined switch position corresponding to the transmitter system's operating frequency band. Stopping the FILTER BANDSWITCH at the pre-determined setting is accomplished when the slotted portion of the S4501-A switch ring, rotated by the stepping switch solenoid, reaches the voltage bearing contact. At this point, the energizing voltage for the relay solenoid of K4500 is removed, deenergizing it and thereby removing the -24 vdc control voltage from the stepping switch solenoid.

Interlock switch protection, preventing the failure of mistuned positioning of the FILTER BANDSWITCH to correspond with the transmitter system's operating frequency band, is performed by switch S4501-B. This switch, ganged to the FILTER BANDSWITCH S4500-A, S4500-B and S4501-A, is connected to the system interlocks via the system r-f control and indicator unit. Failure of the FILTER BANDSWITCH to correlate with the system transmit frequency band setting will cause the transmitter system to react to an open-interlock condition.

The FILTER BANDSWITCH positioning control voltage, stepping switch control solenoid voltage and system interlock wiring are all routed via connector J4502.

SECTION 5 MAINTENANCE

5-1. PREVENTIVE MAINTENANCE.

In order to prevent equipment failure due to dust, dirt or other destructive elements, it is suggested that a schedule of preventive maintenance be set up and adhered to.

At periodic intervals, the equipment should be removed from its mounting for cleaning and inspection. The wiring and all components should be inspected for dirt, dust, corrosion, grease or other harmful conditions. Remove dust with a soft brush or vacuum cleaner. Remove dirt or grease with any suitable cleaning solvent. Use of carbon tetrachloride should be avoided due to its highly toxic effects. Trichlorethylene or methyl chloroform may be used, providing the necessary precautions are observed.

WARNING

When using toxic solvents, make certain that adequate ventilation exists. Avoid prolonged or repeated breathing of the vapor. Avoid prolonged or repeated contact with skin. Flammable solvents shall not be used on energized equipment or near any equipment from which a spark may be received. Smoking, "hot work", etc. is prohibited in the immediate area.

CAUTION

When using trichlorethylene, avoid contact with painted surfaces, due to its paint removing effects.

5-2. TROUBLESHOOTING

When a piece of equipment has been operating satisfactorily and suddenly fails, the cause of failure may be due to symptoms of past failures or due to component aging.

The first step in troubleshooting is to ascertain that proper equipment voltages are present and that all interconnecting cables are secure and functional.

If the above mentioned checks fail to locate the fault, and the fault is known to be that of the TFP, disconnect all interconnecting cables and remove unit from its mounting. Remove access cover and perform a visual check. Observe for trouble-causing conditions such as arcing, grease, dirt, dust or other harmful conditions. Observe for loose connections, broken or burned wires, charred or discolored components. Proceed with the following troubleshooting procedures.

In order to isolate the trouble-causing condition in the TFP, the technician should perform a systematic continuity check of the various TFP component sections. These sections may be categorized as: the harmonic filter sections (AF106), stepping switch S4501, relay K4500, filter bandswitching circuit (S4500) and their associated harness and cable wiring.

The first logical step is to ascertain that the inter-system cabling is correct, operative, and that the required voltages and terminations to the TFP are correct and available. After a general over-all visual inspection of the unit, proceed with a continuity check of the filter bandswitching circuit (S4500) and its associated inter-cabling and wiring.

Refer to figure 5-1 and proceed with a continuity check starting from the input connector CP4501. Continuity should be present from CP4501 to the wiper of S4500-A. Proceed by measuring for continuity from CP4501 to the switch S4500-A output terminals E4512 through E4517 (switching the FILTER BANDSWITCH control through the 2-3 to 13-19 positions respectfully). Continuity through all six positions indicates that the input circuit to the harmonic filter sections is functional.

Perform a similar continuity check for the harmonic filter output circuit. This is performed by measuring from the output connector CP4500 to switch S4500-B output terminals E4518 through E4523. This check is similar to the preceding input continuity check, switching the FILTER BANDSWITCH through the 2-3 to 13-19 positions.

To check the seventh switch position, set the FILTER BANDSWITCH control at 19-30; measure for continuity from CP4500 to CP4501.

Continuity across all of the preceding described points establishes the functional condition of the harmonic filter input/output circuit.

To check the condition of relay K4500, the technician may remove the relay from it's socket and measure for continuity and resistance across it's terminals. The relay solenoid, measured across terminals 2 and 7 should read approximately 400 ohms. Continuity should be present across terminals 5 and 8 and terminals 4 and 1. An open-condition should therefore be measured across terminals 6 and 8 and terminals 3 and 1.

A similar check of the relay K4500 plug-in socket should follow. Terminal 2 of relay K4500 plug-in socket should measure continuity to ground. Terminal 7 should measure continuity to the wiper terminal of switch wafer S4501-A. Terminal 6 should measure continuity to pin R of connector J4502. Terminal 8 should measure continuity to the input of the stepping-switch contactor arm. Terminals 1,3 and 4 are intentionally unused.

The stepping-switch wafers S4501-A and S4501-B contacts are all directly wired to connector J4502. To check the S4501-A section, proceed as follows. Check for continuity from the wiper (terminal 7 of relay K4500 plug-in socket) to connector J4502. Continuity should be measured across pins A through G of connector J4502, except at the pin corresponding to the selected FILTER BANDSWITCH setting, i.e., when set at the 2-3 position an open indication should be measured from the wiper to pin A of J4502, all other pins B through G should measure continuity. Repeat this check through all seven FILTER BANDSWITCH positions.

To check the S4501-B section, proceed as follows. Check for continuity from the wiper of S4501-B (pin Q of J4502) to the pin corresponding to the FILTER BANDSWITCH setting, i.e., when set at the 2-3 position, continuity should be measured at pin H of J4502, measuring an open indication at the remaining pins. Repeat this check through all seven FILTER BANDSWITCH positions.

The stepping-switch solenoid of S4500 operates from an externally-produced -24 volts d-c. Therefore, the surest method for checking the condition of the motor is to apply a -24 volts d-c potential to the input contactor arm via terminal 8 of relay

K4500 plug-in socket, with relay removed. Application of -24 volts d-c to the stepping switch solenoid should cause it to operate. While the switch wiper is rotating, visually inspect the components, i.e., switch wafers, shaft, shaft-couplers, etc, for smooth and trouble-free operation.

Assuming that all preceding checks failed to locate the fault, it may be assumed that the fault lies in the harmonic filter sections. The faulty harmonic filter section should be evident to the particular FILTER BANDSWITCH control range used when the fault occurred.

Remove the suspected harmonic filter section and inspect, check and replace the faulty component.

The preceding checks may be further enhanced or shortened as to the technicians own methods, troubleshooting techniques and short-cuts. Use of the schematic diagram in section 7 and the parts list in section 6 should be used as a guide and reference.

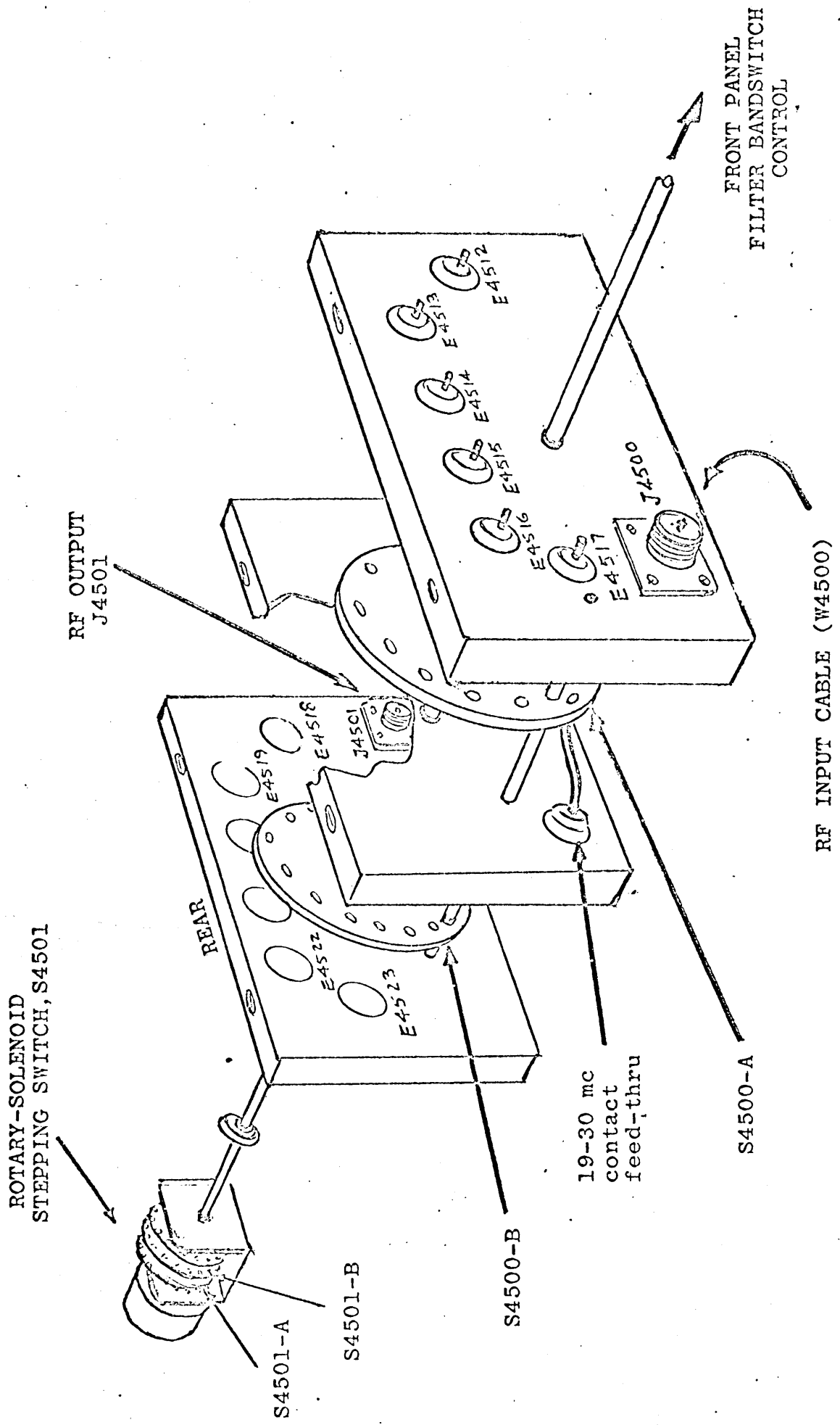

Figure 5-1. Switch Assembly, AX664

5-3. REPAIR AND REPLACEMENT

Maintenance of the TFP will consist mainly of component replacement, requiring no tuning or aligning. It should be noted that when replacing components having many wires connected, such as switches, relays, etc., the wires should first be tagged and marked for accurate identification when replacing.

When replacing components, the technician should observe for exact or equivalent replacements, by referring to the parts list in section 6.

Positioning and polarity of certain components should be observed before removing, so that the replacement component will fit and operate correctly. See figure 5-2 for component locations.

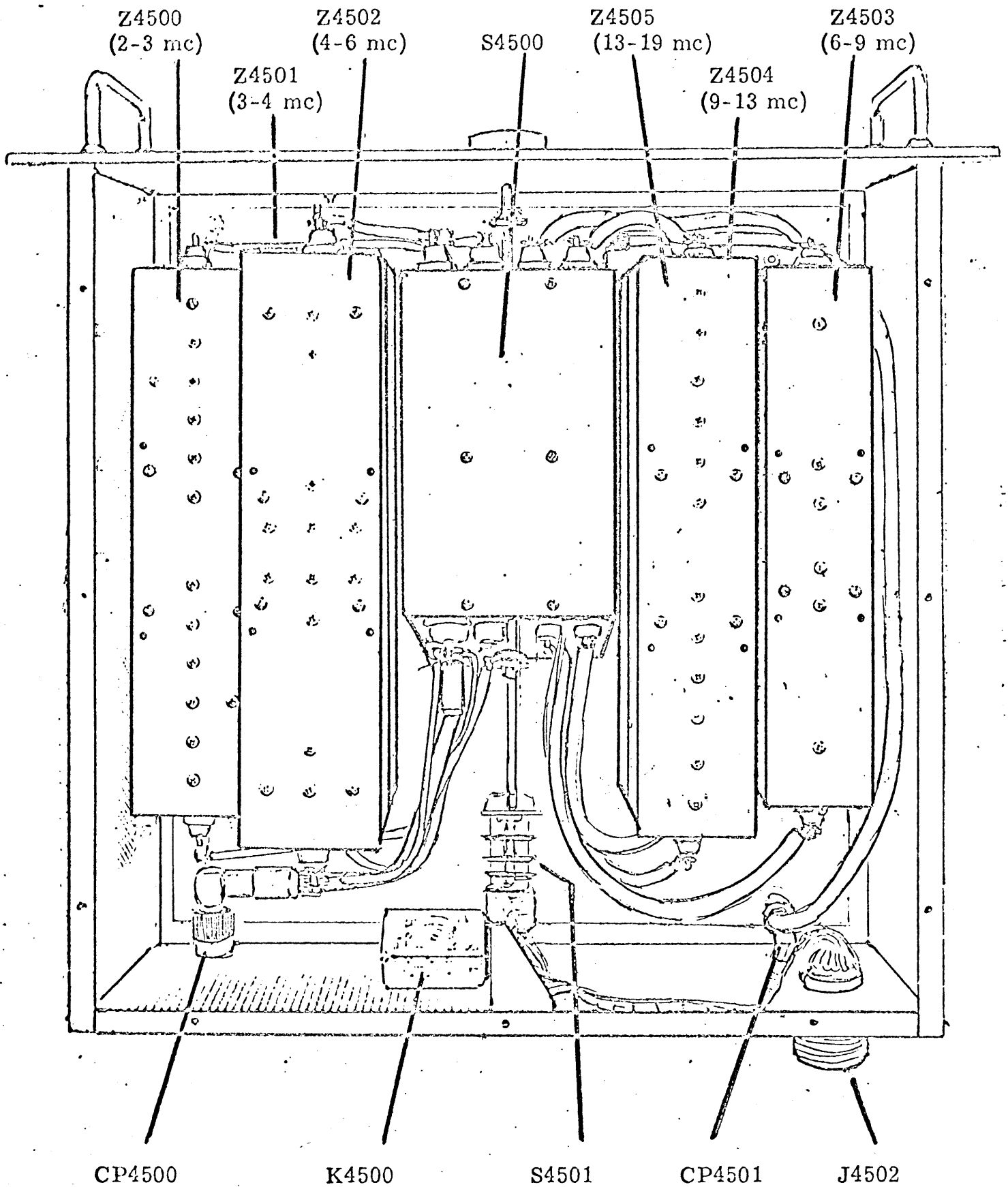

Figure 5-2. Bottom Chassis Component Layout.

SECTION 6 PARTS LIST

6-1. INTRODUCTION

The parts list presented in this section is a cross-reference list of parts identified by a reference designation and TMC part number. In most cases, parts appearing on schematic diagrams are assigned reference designations in accordance with MIL-STD-16. Wherever practicable, the reference designation is marked on the equipment, close to the part it identifies. In most cases, mechanical and electro-mechanical parts have TMC part numbers stamped on them.

To expedite delivery when ordering any part, specify the following:

- a. Reference symbol.
- b. Description as indicated in parts list.
- c. TMC part number.
- d. Model and serial numbers of the equipment containing the part being replaced; this can be obtained from the equipment nameplate.

For replacement parts not covered by warranty (refer to warranty sheet in front of manual), address all purchase orders to:

The Technical Materiel Corporation
Attention: Sales Department
700 Fenimore Road
Mamaroneck, New York

PARTS LIST

for

HARMONIC FILTER, TFP-2.5K

REF SYMBOL	DESCRIPTION	TMC PART NUMBER
C4500	CAPACITOR, FIXED, CERAMIC DIELECTRIC: 500 uuf, $\pm 10\%$; 5,000 WVDC.	CC109-36
C4501 thru C4514	Same as C4500	
C4515	CAPACITOR, FIXED, CERAMIC DIELECTRIC: 100 uuf, $\pm 10\%$; 5,000 WVDC.	CC109-28
C4516	Same as C4515	
C4517	Same as C4515	
C4518 thru C4525	Same as C4500	
C4526 thru C4528	Same as C4515	
C4529	Same as C4500	
C4530	Same as C4500	
C4531 thru C4533	Same as C4515	
C4534 thru C4536	Same as C4500	
C4537	Same as C4515	
C4538 thru C4540	Same as C4500	
C4541 thru C4544	Same as C4515	
C4545 thru C4551	Same as C4500	

PARTS LIST

for

HARMONIC FILTER, TFP-2.5K

REF SYMBOL	DESCRIPTION	TMC PART NUMBER
C4552 thru C4555	Same as C4515	
C4556	Same as C4500	
C4557	Same as C4515	
C4558	Same as C4500	
C4559 thru C4566	Same as C4515	
C4567	CAPACITOR, FIXED, CERAMIC DIELECTRIC: 50 uuf, $\pm 10\%$; 7,500 WVDC.	CC109-19
C4568 thru C4570	Same as C4515	
C4571	Same as C4567	
C4572	Same as C4515	
C4573	Same as C4515	
CP4500	ADAPTER, HN to HN	UG1019/U
CP4501	Same as CP4500	
CR4500	ABSORBER, OVERVOLTAGE: operation voltage range 28 to 33 volts; max. reverse voltage 10 VDC; current rating 750 ma; 1 watt Zener; tantalum capacitor 1 uf, 35 WVDC;	DD111-1
E4500	INSULATOR, FEEDTHRU: consits of a teflon insulator one brass, nickel plated 10-32 X 1 1/2" phillips- head screw, two flat washers, one split washer, and two hex nuts.	AX663
E4501 thru E4523	Same as E4500	
J4500	RECEPTACLE, HN TYPE	UG560*/U
J4501	Same as J4500	

PARTS LIST

for

HARMONIC FILTER, TFP-2.5K

REF SYMBOL	DESCRIPTION	TMC PART NUMBER
J4502	CONNECTOR, PLUG, MALE; part of W4502.	MS3102A24-28B
K4500	RELAY, ARMATURE: 24 VDC, 400 ohms; contacts rated for 10 amps resistive, 5 amps inductive at 115 VAC or 26 VDC; nominal coil power required 1 to 2 watts; 500 V RMS; plug-in type; inclosed clear plastic case.	RL168-2C10-24DC
L4500	COIL, RADIO FREQUENCY; fixed; 3.9 uh.	CL401-4
L4501	COIL, RADIO FREQUENCY; fixed; 3.9 uh.	CL401-5
L4502	Same as L4500	
L4503	COIL, RADIO FREQUENCY; fixed; 2.7 uh.	CL401-6
L4504	COIL, RADIO FREQUENCY; fixed; 2.9 uh.	CL401-7
L4505	Same as L4503	
L4506	COIL, RADIO FREQUENCY; fixed; 1.9 uh.	CL401-8
L4507	COIL, RADIO FREQUENCY; fixed; 2.1 uh.	CL401-9
L4508	Same as L4506	
L4509	COIL, RADIO FREQUENCY; fixed; 1.2 uh.	CL401-10
L4510	COIL, RADIO FREQUENCY; fixed; 1.3 uh.	CL401-11
L4511	Same as L4509	
L4512	COIL, RADIO FREQUENCY; fixed; .93 uh.	CL401-12
L4513	COIL, RADIO FREQUENCY; fixed; 1.0 uh.	CL401-13
L4514	Same as L4512	
L4515	COIL, RADIO FREQUENCY; fixed, .58 uh.	CL401-14
L4516	COIL, RADIO FREQUENCY; fixed; .67 uh.	CL401-15
L4517	Same as L4515	
P4500	PLUG, RIGHT ANGLE; HN TYPE	PL253-1
P4501	Same as P4500	
P4502	Same as P4500	

PARTS LIST

for

HARMONIC FILTER, TFP-2.5K

REF SYMBOL	DESCRIPTION	TMC PART NUMBER
P4503	PLUG; HN TYPE	UG59*/U
S4500	Consists of 2 switch wafers and amotorized 3 wafer switch coupled together by extension shafts and fixed and flexible couplers.	P/O AX664
S4501		P/O AX664
W4500	CABLE, RF consists of RG165/U and P4500 and P4503	CA480-149-27
W4501	CABLE, RF consisto of RG165/U and P4501 & P4502	CA480-148-10.5
W4502	BRANCHED WIRING HARNESS	CA1330
XK4500	SOCKET, RELAY: 8 contacts, saddle type.	TS101P01
Z4500	HARMONIC FILTER; 2-3 mc	AF106-1
Z4501	HARMONIC FILTER; 3-4 mc	AF106-2
Z4502	HARMONIC FILTER; 4-6 mc	AF106-3
Z4503	HARMONIC FILTER; 6-9 mc	AF106-4
Z4504	HARMONIC FILTER; 9-13 mc	AF106-5
Z4505	HARMONIC FILTER; 13-19 mc	AF106-6

SECTION 7
SCHEMATIC DIAGRAMS

SECTION 7
SCHEMATIC DIAGRAMS

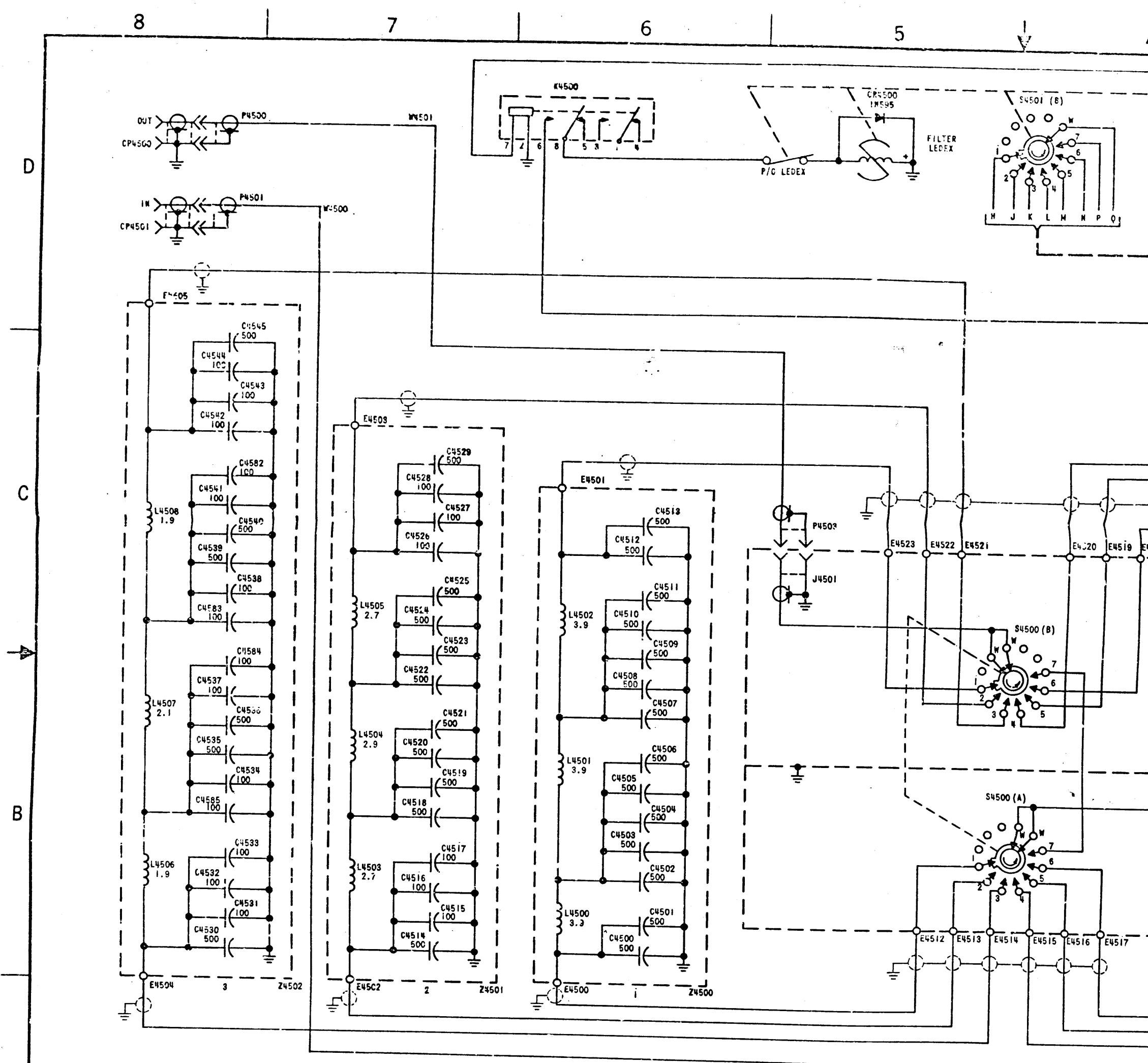

4000 SERIES	
LIST SYM.	WISCONSIN SYM.
C4505	
CP4500	
CP4501	
CR4500	
C4523	
K4502	
K4500	
L4517	
P4500	
P4501	
W4502	
Z4501	

S4500 BAND MHz	
POS.	FUNCTION
1	2-3
2	3-4
3	4-6
4	5-9
5	9-13
6	13-19
7	19-30

UNLESS OTHERWISE SPECIFIED:
 1. ALL COILS ARE IN UF
 2. ALL CAPACITORS ARE IN PF

QTY	UNIT	TRF-
		MISC
		APP

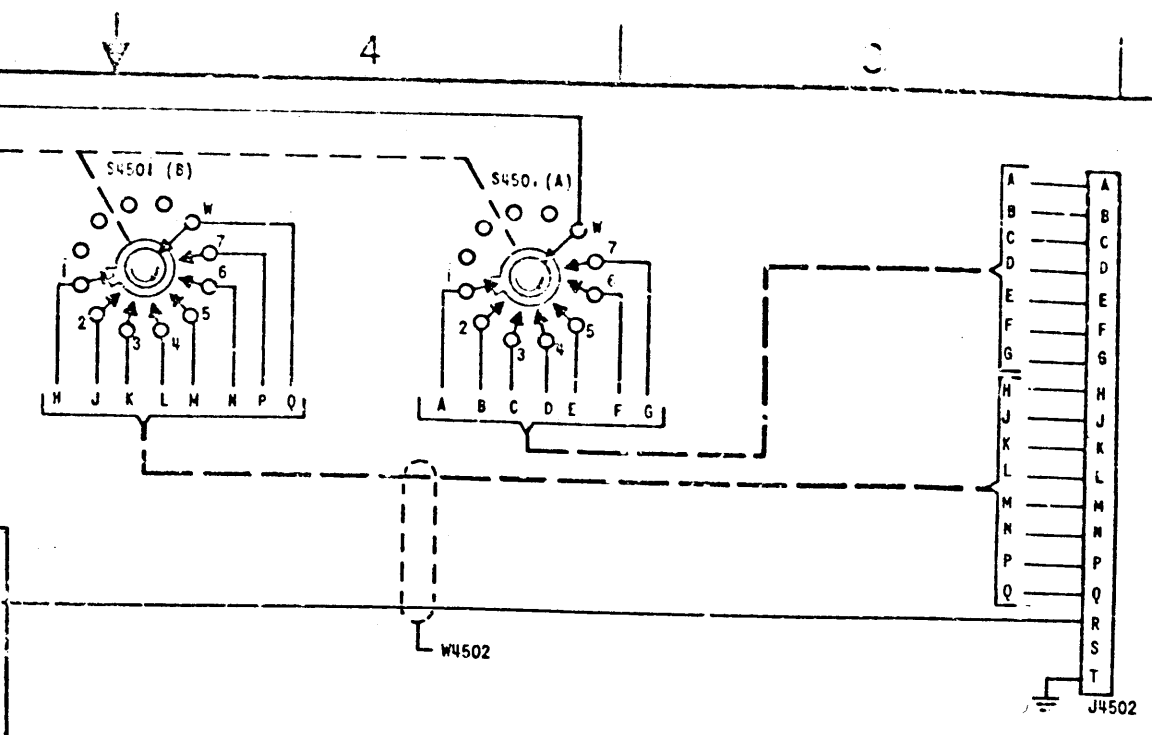

REVISIONS						
REV.	LET.	DESCRIPTION	DATE	BY	CHKD.	APPD.
X2		REVISED & REDRAWN	4-2-68			

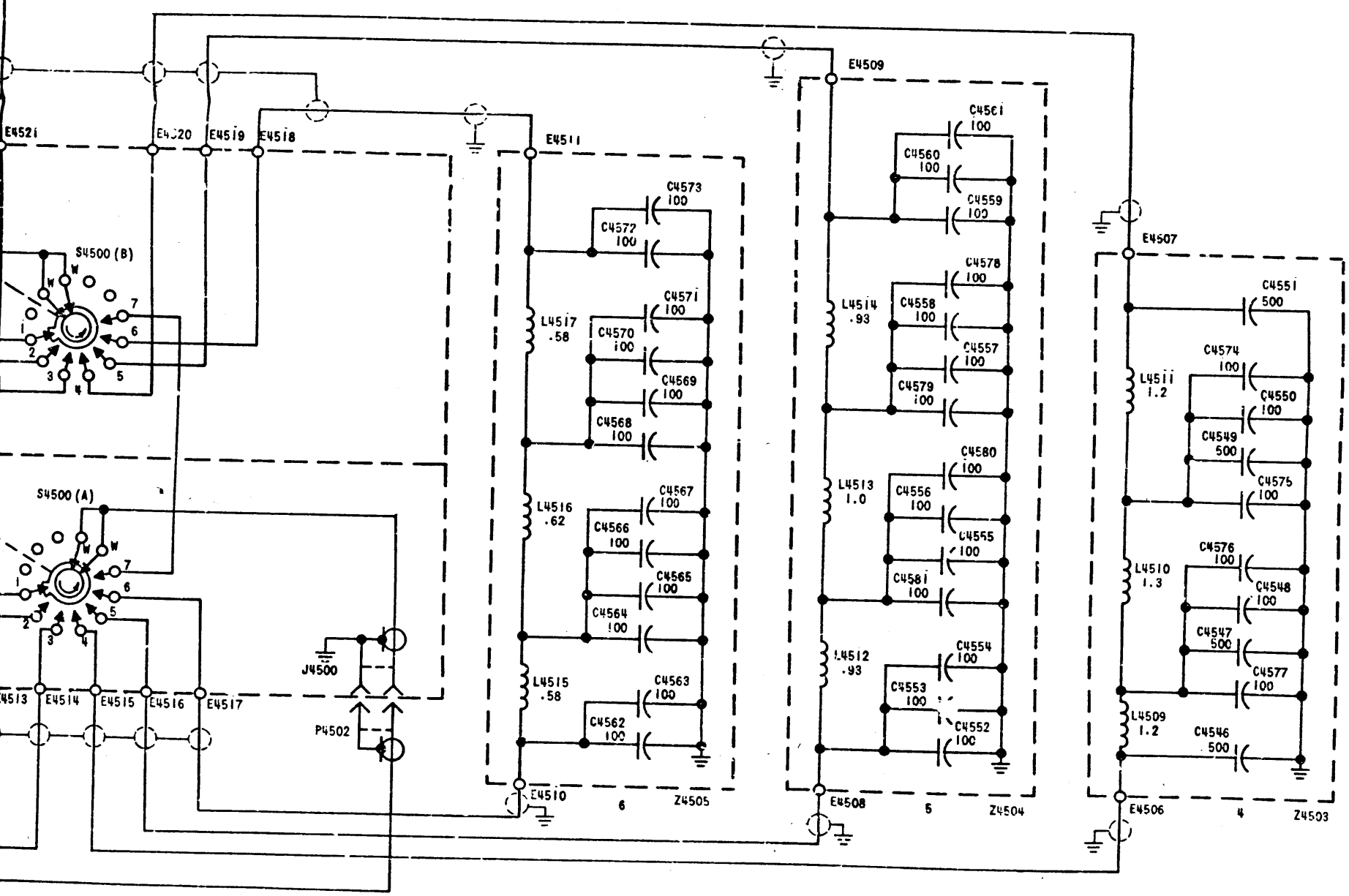

B CK1306

1	TFP-2.5K	AF106
QTY / UNIT	MODEL USED ON	ASSY. NO.
APPLICATION		

UNLESS OTHERWISE SPECIFIED DIMENSIONS ARE IN INCHES AND INCLUDE CHEMICALLY APPLIED OR PLATED FINISHES

TOLERANCES ON

DECIMALS	FRACTIONS
X = .05	± 1/64
XX = .01	ANGLES
XXX = .005	± 0° 30'

MATERIAL

FINISH

QTY. REC.	ITEM	PART NO.	DESCRIPTION	SYMBOL
F. BUDETTI				
LIST OF MATERIAL				
THE TECHNICAL MATERIEL CORP. MAMARONECK, NEW YORK				
DIAGRAM, SCHEMATIC				
D 32679 CK1306				ISSUE