

## SALES SERVICE BULLETIN NUMBER 156B

Rhombic Terminal Unit, Models RTB

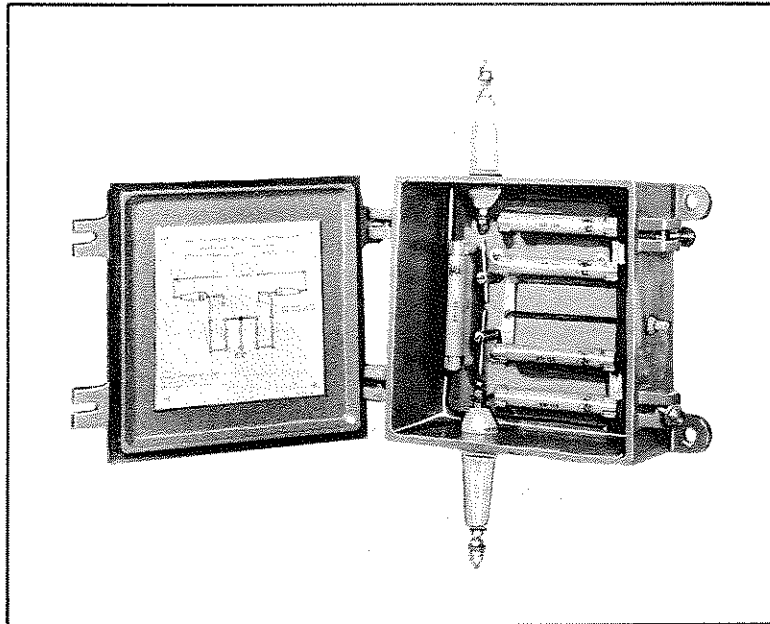

Rhombic Terminal Unit, Model RTB

The Models RTB Rhombic Terminal Units were designed to complement the Models RAC Rhombic Antenna Couplers, and provide rugged and proper connections for the antenna.

The series has recently been redesigned to provide additional resistance coverage and center taps on all units. The table on the reverse side will indicate those standard units available.

The Model RTB consists of 2 or 4 resistors as required, to provide terminations of 280, 600 or 700 ohms, plus a spare resistor mounted within the case. The resistors are plug-in, ferrule type for ease of maintenance and replacement.

A built-in lightning arrester prevents the build up of static charges which might damage associated equipment.

### TECHNICAL SPECIFICATIONS:

<b>TERMINATION RESISTANCE:</b>	280, 600 or 700 ohms, center tapped. Other values available on request.
<b>EQUIPMENT CASE:</b>	Weather resistant, cast of aluminum alloy.
<b>INPUT TERMINALS:</b>	Two ceramic insulators properly spaced to accommodate Rhombic terminals.
<b>GROUND CONNECTION:</b>	A coaxial ground connection is provided on the bottom of the case.

**MOUNTING:** Pole mounting by means of four heavy cast mounting flanges. Four 1/2" dia. holes on 7-3/4" x 10-1/4" mounting centers.

**DIMENSIONS:** 9 x 9 x 5 inches

**WEIGHT:** 18 pounds

**SHIPPING WEIGHT:** 35 pounds

**COMPONENTS AND CONSTRUCTION:** Equipment is manufactured in accordance with JAN/MIL specifications wherever practicable.

**MODELS AVAILABLE**

MODEL NO.	TERMINATION	RESISTOR PART NUMBER
RTB-3	280 ohms	2 each RR-115-140
RTB-4	700 ohms	4 each RR-115-175
RTB-5	600 ohms	4 each RR-115-150

**ADDITIONAL REPLACEMENT PARTS**

Hardware Kit	BM-212
Insulator Assy.	A-102
Cover Gasket	GA-103

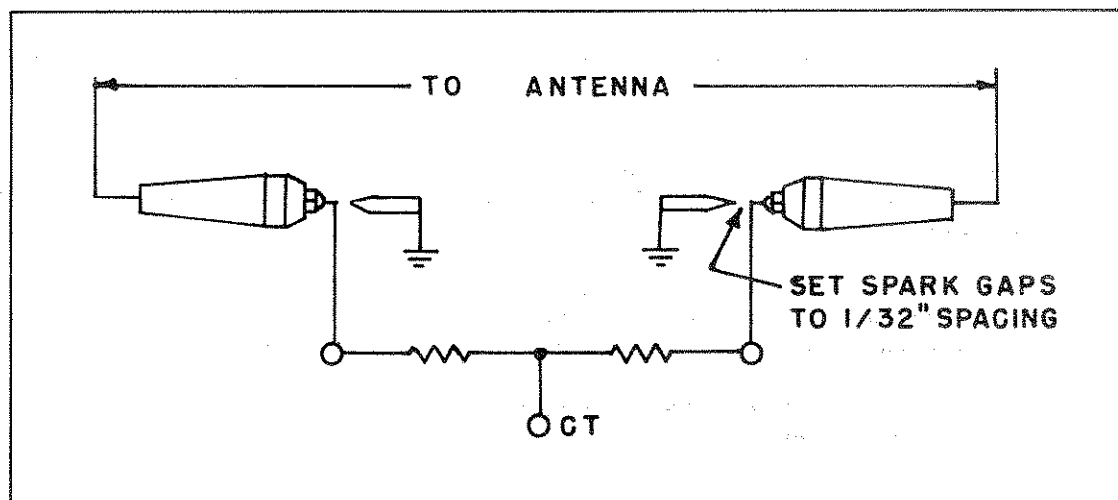

Rhombic Terminal Unit, Model RTB

COPYRIGHT, 1958  
THE TECHNICAL MATERIEL CORP.

PH-RTB-4

**THE TECHNICAL MATERIEL CORPORATION**

700 FENIMORE ROAD

MAMARONECK, NEW YORK

CABLE  
TEPEI  
MAMARONECK, N.Y.

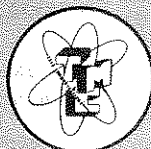

COMMUNICATION ENGINEERS

IN CANADA:  
TMC (CANADA) LTD.  
OTTAWA, ONTARIO