

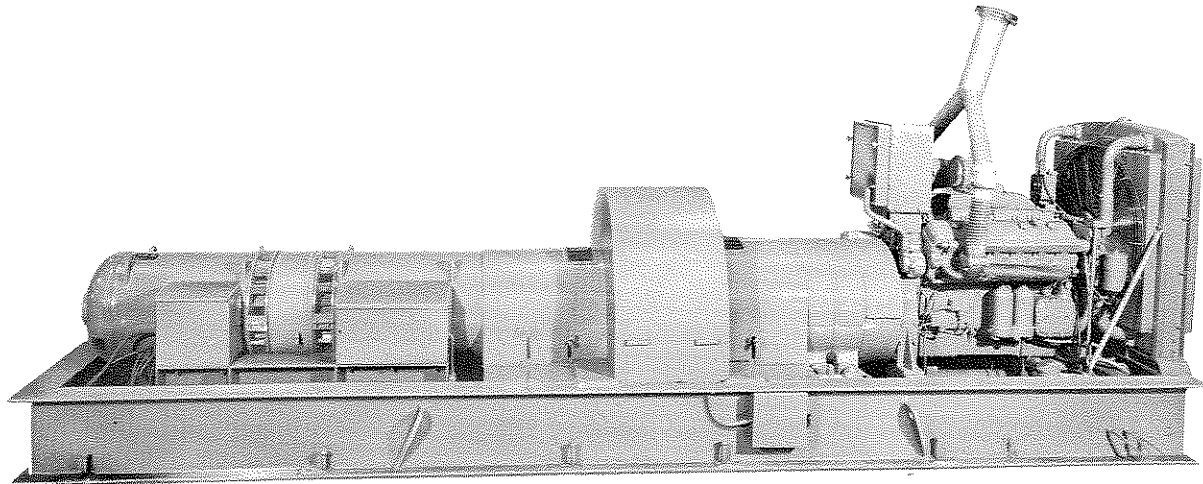

DEC 27 1963
TECHNICAL BULLETIN NUMBER 505

"Precise No Break" Systems
TMC Model PFS 200 PNB
(PU-583/G)



Model PFS 200 PNB

The TMC Power Distribution "No Break" generators are continuous power systems which provide uninterrupted sine-wave generation of power with precise regulation of output voltage and frequency. The Precise No-Break generators assure electrical isolation of critical loads from commercial or other primary power sources which are subject to variation. Constant monitoring of input and output voltage, frequency, and motor current by solid state sensing units and solid state regulators maintains output voltage to within $\pm 1\%$ and output frequency within one-sixth of a cycle under conditions of no load to full rated load.

Electrical isolation from commercial power lines allows customer selection of load frequency, without regard to commercial power line frequency, thus permitting the use of standard electronic and asynchronous terminal equipment.

Model PFS 200 PNB (PU-583/G) consists of a diesel engine, an eddy-current clutch, a flywheel, a synchronous motor and an alternator mounted in-line on a common rigid base and the electrical controls required for operation. The engine is equipped with an electrically actuated, hydraulic starting system with high cranking torque which enables the engine to reach operating speed in 1-1/2 seconds; and a secondary, back-up starting system utilizing the inertia of the flywheel. The isochronous engine governor has two modes of operation—electrical control utilizing a

solid state load and frequency sensing unit and centrifugal control. The specially designed motor and alternator are brushless with rotating fields for minimum RF interference. The electrical controls of the Model PFS-200 PNB include motor operated circuit breakers, monitoring meters, solid state sensing units and sealed relays.

This system has been furnished to many overseas and U. S. installations and is providing power to critical communication systems. These systems have met or exceeded customer requirements and have provided continuous power through as many as twenty commercial power drop-outs daily.

These systems are also available with 100, 150, 250, and 300 kw capacity, with many customer options of voltages and frequencies.

ELECTRICAL SPECIFICATIONS

RATED POWER:	250 KVA, 0.8 PF with 10% overload for 1 hour.
OUTPUT:	120/208 volt or 240/416 volt, 60 cycle, 3 phase.
VOLTAGE REGULATION:	$\pm 1\%$ from 0 load to 100% load.
VOLTAGE TRANSIENTS: NO LOAD TO F.L. F.L. TO NO LOAD	Less than 9% dip. Less than 7.5% rise
FREQUENCY REGULATION:	1/6 of 1%.
FREQUENCY TRANSIENTS:	Less than 1% droop after failure of primary power.
INPUT:	208 or 480 volt, 60 cycle, 3 phase.
SAFETY FEATURES:	Engine lock-out control, engine protection shutdown, flywheel bearing overtemperature protection, alternator failure protection and fuse protection of control circuits.

COMPONENTS

ENGINE:	GM Detroit Diesel 7123-7000 (12V71N)
STARTING SYSTEM: PRIMARY: SECONDARY:	Automatic Hydrostarter with 5 accumulators. Engagement to the inertia flywheel.
GOVERNOR:	Woodward EG-B1, electric load and frequency sensing with centrifugal backup.
CLUTCH:	Eaton eddy current, special design.
COUPLINGS:	Internal gear type
INERTIA FLYWHEEL:	Single forged steel, SAE 4340, vacuum poured, 56" x 24".
FLYWHEEL BEARINGS:	Oversized tapered bearings sized for 300,000 hours operation.

MOTOR:	TMC Power 300 HP brushless synchronous motor special design for no-back loading into a direct short, manufactured by Delco Products.
ALTERNATOR:	Brushless synchronous alternator with rotating field, manufactured by Delco Products.
BASE:	Fabricated steel with machined mounting surfaces.

CONTROLS

CABINETS:	Two NEMA free standing cabinets, dead front.
BREAKERS:	Motor-operated molded case breakers for alternator to load and for primary to load (generator set bypass).
MOTOR CONTACTORS:	NEMA—size solenoid operated contractors
METERS:	1% accuracy, 4½", 270° meters for voltage, current, power, frequency and elapsed time; also synchroscope.
VOLTAGE REGULATOR:	Instant response solid state three transistor model.

Standard equipment includes solid state sensing and monitoring devices, automatic synchronizers, heavy duty sealed relays, current and potential transformers, terminal blocks and fuse blocks.

OTHER TECHNICAL DATA

INSTALLATION DATA:	
GENERATOR LENGTH:	22' 6"
GENERATOR WIDTH:	5' 8"
GENERATOR HEIGHT:	6' 11"
CABINETS:	30" x 30" x 70"
WEIGHT:	39,000 lbs. (approx.)
ENVIRONMENTAL CONDITIONS:	Unit is designed to operate in any ambient temperature from -40° C to +50° C and normal environmental humidity conditions.

OPTIONAL EQUIPMENT

The following options are available at extra cost and may be added to the system:

1. Remote monitoring
2. Remote monitoring and remote operation
3. Alarm system
4. Tie-in control of existing standby generators for non-critical service.
5. Integrated fuel systems
6. Pre-fabricated environmental shelters

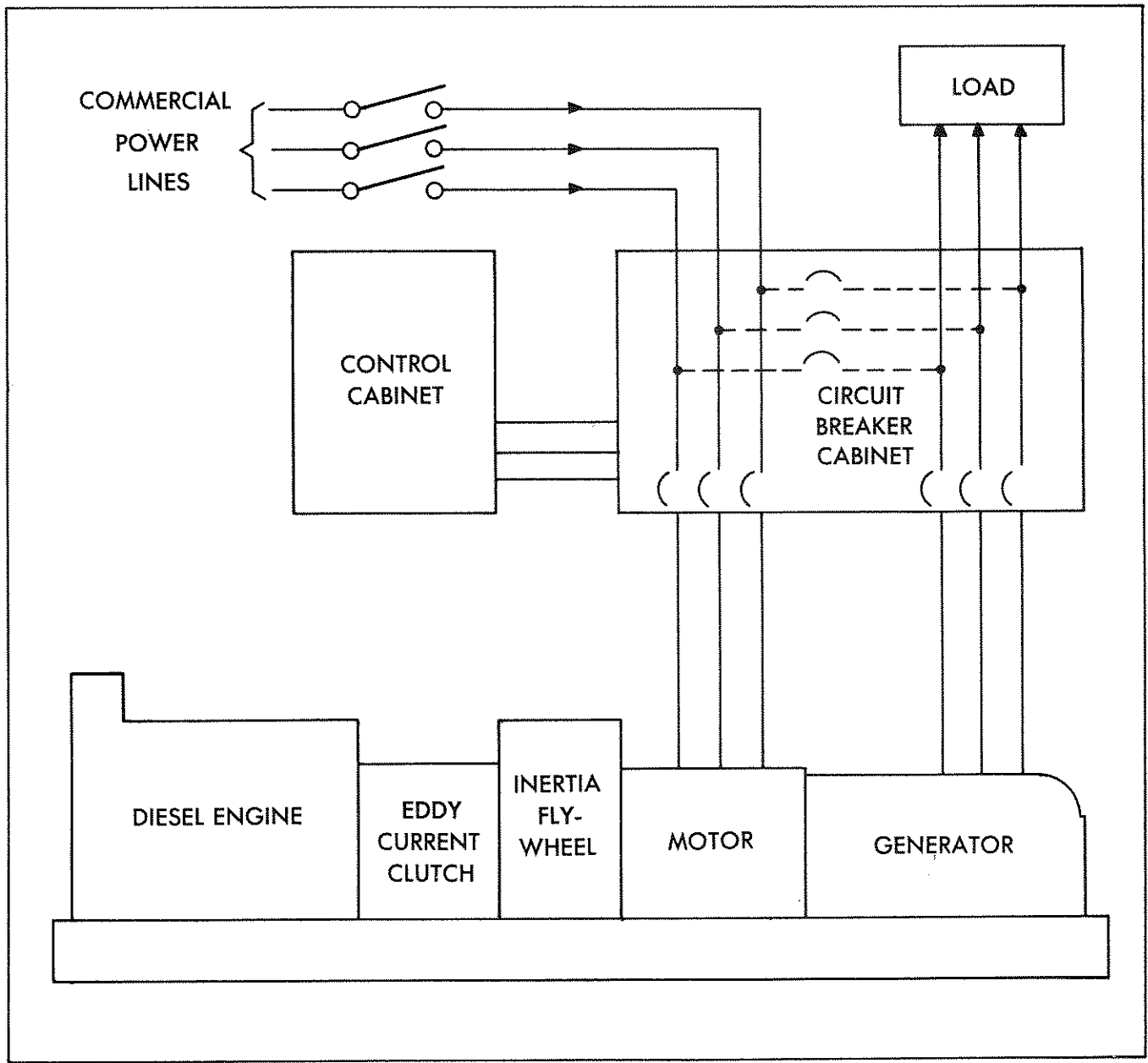

FUNCTIONAL BLOCK DIAGRAM "PRECISE NO-BREAK" POWER SYSTEM

COPYRIGHT 1963
THE TECHNICAL MATERIEL CORP.

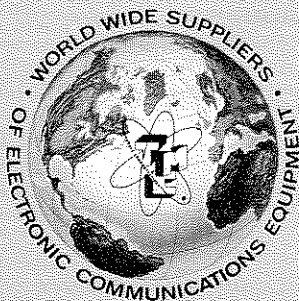

T.M.C. POWER DISTRIBUTION INC.

A SUBSIDIARY OF THE TECHNICAL MATERIEL CORPORATION

4412-4414 WHEELER AVE.

ALEXANDRIA, VIRGINIA