

A-1084

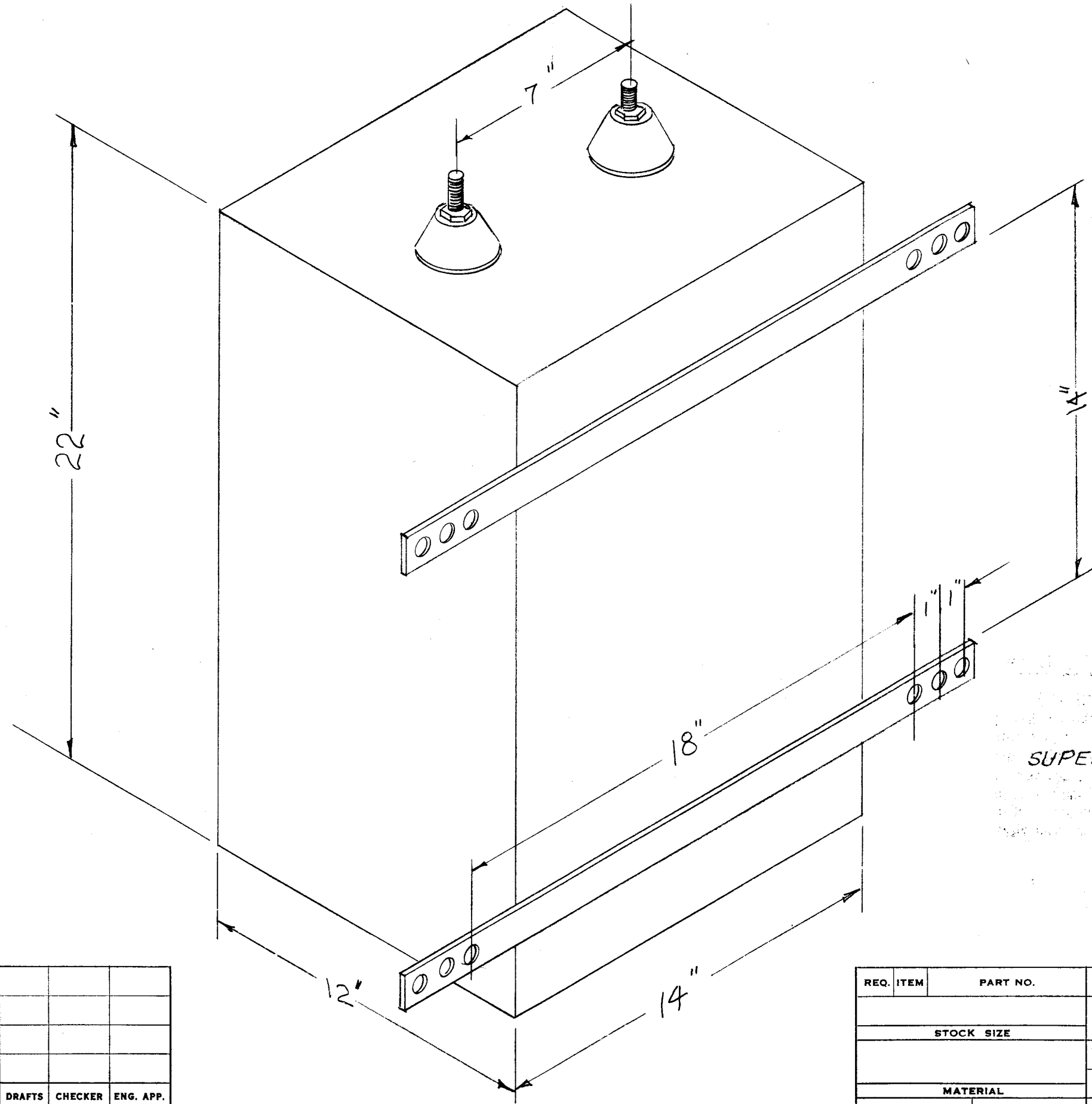

NOTICE TO PERSONS RECEIVING THIS DRAWING

THE TECHNICAL MATERIEL CORPORATION claims proprietary right in the material disclosed hereon. This drawing is issued in confidence for engineering information only and may not be reproduced or used to manufacture anything shown hereon without permission from THE TECHNICAL MATERIEL CORPORATION to the user. This drawing is loaned for mutual assistance and is subject to recall at any time.

Property of:
THE TECHNICAL MATERIEL CORPORATION
MAMARONECK, NEW YORK

SUPERCEDED BY A-1220

ISSUE	ITEM	CHANGED FROM	DATE	CH. NO.	DRAFTS	CHECKER	ENG. APP.
TOLERANCES			SCALE:				
DEC. DIM. ±			MAXIMUM ALLOWABLE TOLERANCES HAVE BEEN DETERMINED AND ANY DEVIATIONS WILL BE CAUSE FOR REJECTION.				
FRAC. DIM. ±			REMOVE ALL BURRS AND SHARP EDGES				
ANGULAR DIM. ±							

REQ. PER UNIT	TER-3500	PROJECT NO.	ASS'Y. NO.	DATE
	MODEL			9/2/55
USED ON				

REQ. ITEM	PART NO.	DESCRIPTION	SYMBOL
THE TECHNICAL MATERIEL CORP. MAMARONECK, NEW YORK			
STOCK SIZE			
PHYSICAL DIMENSIONS			
MATERIAL			
MODEL TER-3500			
TYPE & TEMPER	HEAT TREAT. SPEC.	DRAWN	CHECKED
		<i>JND</i>	<i>APP</i>
FINISH & SPEC. NO.	ELEC. DES. APP.	MECH. DES. APP.	
			A-1084