

A-1555

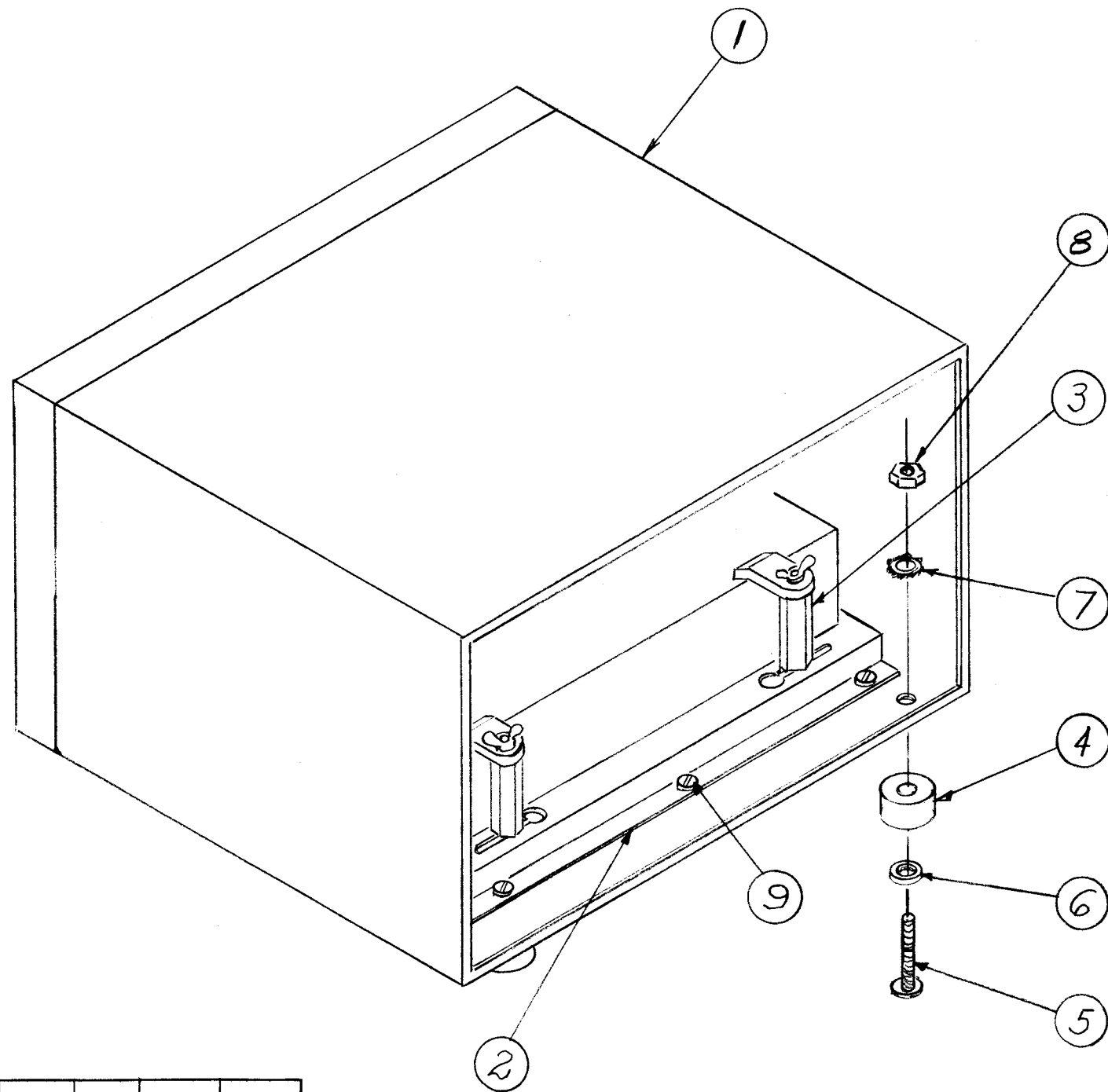

NOTICE TO PERSONS RECEIVING THIS DRAWING

THE TECHNICAL MATERIEL CORPORATION claims proprietary right in the material disclosed hereon. This drawing is issued in confidence for engineering information only and may not be reproduced or used to manufacture anything shown hereon without permission from THE TECHNICAL MATERIEL CORPORATION to the user. This drawing is loaned for mutual assistance and is subject to recall at any time.

Property of:

THE TECHNICAL MATERIEL CORPORATION
MAMARONECK, NEW YORK

6	9	SFB0832SC6	SCREW, SELF TAPPING
4	8	NTH1032BC12	NUT, HEX
4	7	LWE10MRC	LOCKWASHER, EXT.
4	6	FW10HBC	WASHER, FLAT
4	5	SCBS1032BC20	SCREW, MACHINE
4	4	PX-277	MOUNT, CASE & SPEAKER
2	3	A-1523-3	CHASSIS, CLAMP ASSY
1	2	MS-1288	SUPPORT, CHASSIS
1	1	MS-1287	CABINET, ELECTRICAL

REQ. ITEM	PART NO.	DESCRIPTION	SYMBOL
CRO		THE TECHNICAL MATERIEL CORP. MAMARONECK, NEW YORK	
STOCK SIZE		CABINET, ELECTRICAL ASSY	
CRO		MATERIAL	
CRO	CRO	6-19-58	JHE
TYPE & TEMPER	HEAT TREAT. SPEC.	DRAWN	CHECKED
CRO		JHE	FINAL APPROVAL
FINISH & SPEC. NO.		ELEC. DES. APP.	MECH. DES. APP.
			A-1555

ISSUE	ITEM	CHANGED FROM	DATE	CH. NO.	DRAFTS	CHECKER	ENG. APP.
TOLERANCES			SCALE:				
DEC. DIM. ±			MAXIMUM ALLOWABLE TOLERANCES HAVE BEEN DETERMINED AND ANY DEVIATIONS WILL BE CAUSE FOR REJECTION.				
FRAC. DIM. ±			REMOVE ALL BURRS AND SHARP EDGES				
ANGULAR DIM. ±							

1	MSR-4			6-19-58
1	MSR-3			6-19-58
1	MSR-1			6-19-58
REQ. PER UNIT	MODEL	PROJECT NO.	ASSY. NO.	DATE
USED ON				