

IF IT IS FOUND DESIRABLE TO CHANGE ANY TOLERANCE OR OTHER DETAIL SPECIFIED ON THIS DRAWING NOTIFY THE PURCHASER PROMPTLY.

MAXIMUM ALLOWABLE TOLERANCES HAVE BEEN DETERMINED AND DEVIATIONS WILL BE CAUSE FOR REJECTION. REMOVE ALL BURRS AND SHARP EDGES

A-211 A

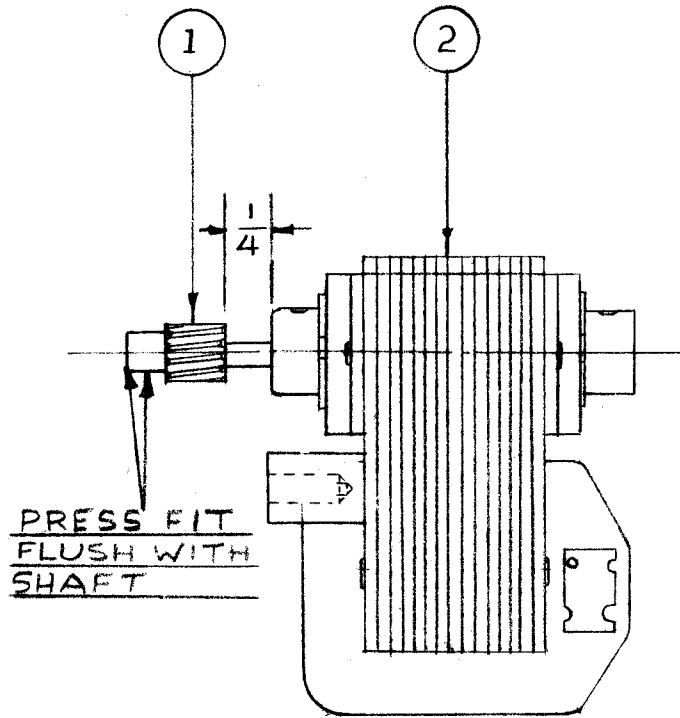
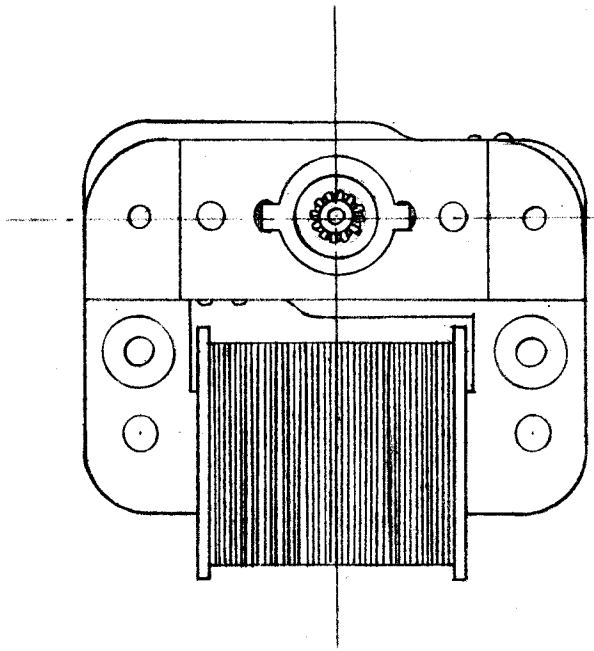

1	2	MO-101-2	MOTOR	
1	1	GR-104	PINION GEAR	
REQ.	ITEM	PART NO.	DESCRIPTION	SYMBOL
—//—			THE TECHNICAL MATERIEL CORP. MAMARONECK. NEW YORK	
STOCK SIZE				
—//—		//	MOTOR ASSEMBLY	
MATERIAL		WEIGHT PER PC.		
—//—				
TYPE & TEMPER		16 10-23-52		<i>PMB</i>
—//—				
HEAT TREAT. SPEC.		<i>ADe 11/6/52</i>		
—//—				
FINISH & SPEC. NO.				

A	1	ITEM 2 WAS MO-101-1	1/19/54	1	16	JAD	WDC
ISSUE	ITEM	CHANGED FROM	DATE	CN. NO.	DRAFTS	CHECKER	ENG. APP.
TOLERANCES		SCALE: FULL SIZE					
ALL OTHERS	DEC. DIM. ± FRAC. DIM. ± ANGULAR DIM. ±	DRILL, PUNCH, COMMERCIAL STOCK SIZES AND MANUFACTURERS TOLERANCES ARE NOT INCLUDED.					

TWR-115	151	A-237	10-23-52
MODEL	PROJECT NO.	ASS'Y. NO.	DATE

USED ON



A-211