

STEP-1
PART-1 (2REQ.)

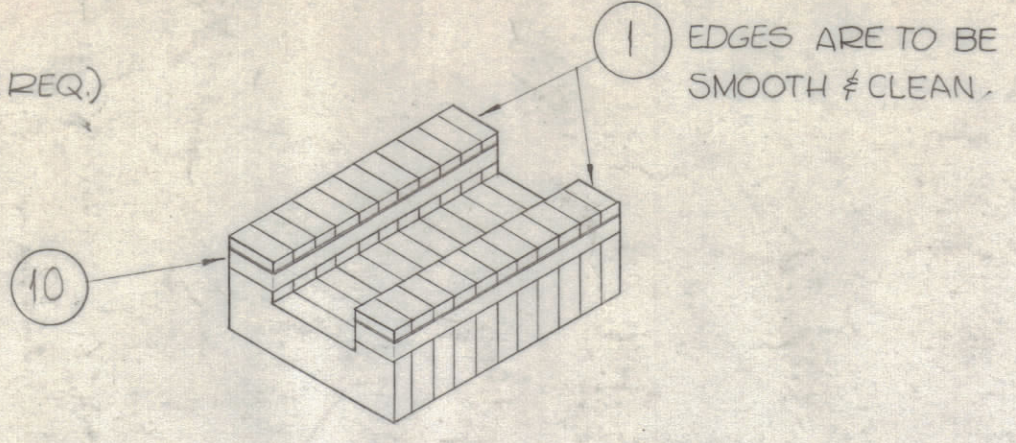

TAPE 11 PIECES OF ITEM 1, USING 2 LAYERS OF ITEM 10 AS SHOWN.

STEP-2
PART-2 (1REQ.)

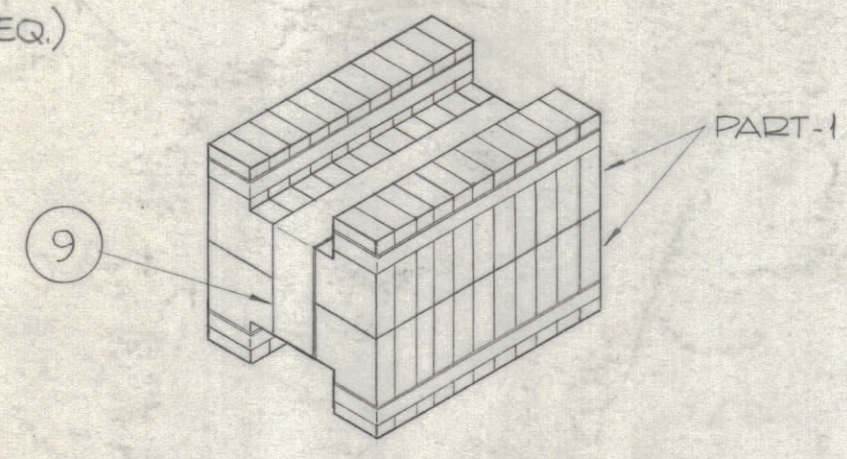

TAPE 2 PART-1 PIECES TOGETHER, USING 2 LAYERS OF ITEM 9 AS SHOWN.

STEP-3
PART-3 (2REQ.)

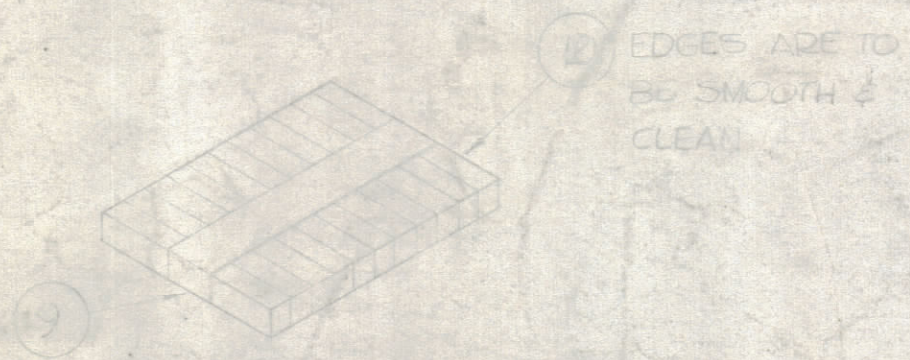

USING ITEM 9, TAPE 11 PIECES OF ITEM 2 TOGETHER AS SHOWN.

STEP-3
PART-3 (2REQ.)

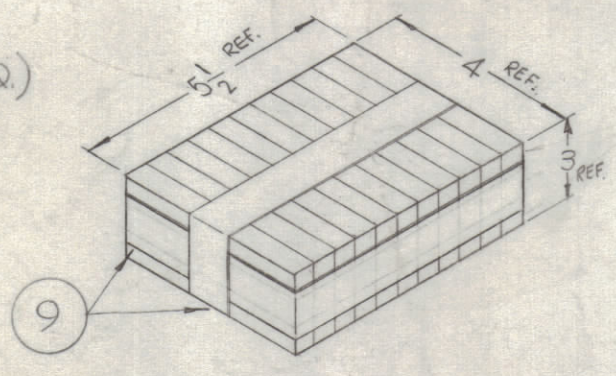

USING 2 LAYERS OF ITEM 9, TAPE 33 PIECES OF ITEM 2, AS SHOWN.

STEP-4
PART-4 (2REQ.)

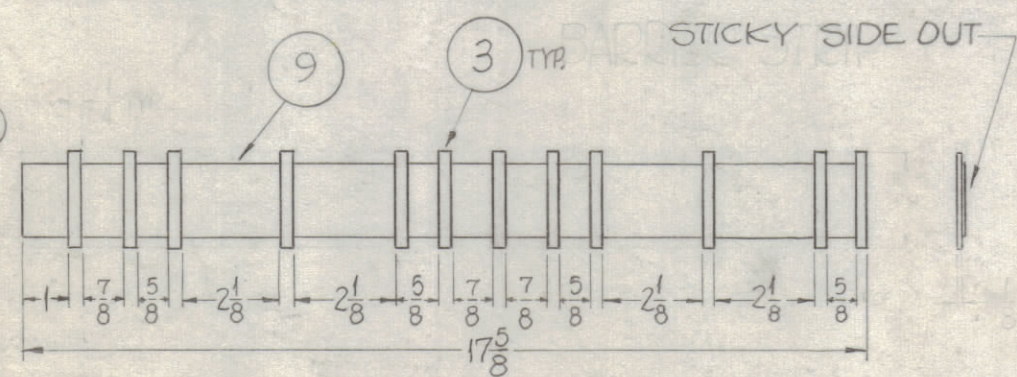

ATTACH ITEM 3 TO ITEM 9 USING 1 LAYER AS SHOWN.

STEP-5
PART-5 (2REQ.)

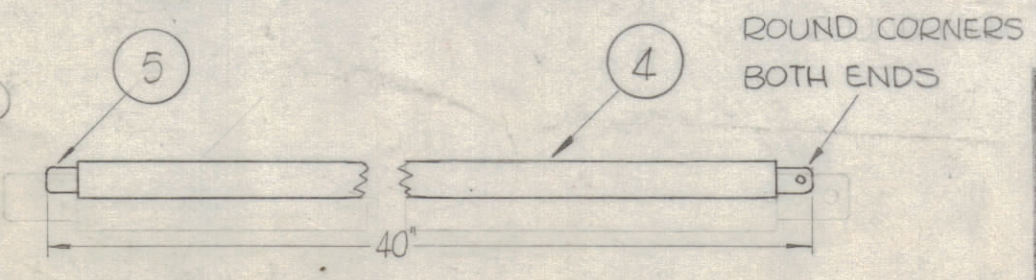

ASSEMBLE ITEM 5 TO ITEM 4 AS SHOWN.

STEP-6
PART-7 (2REQ.)

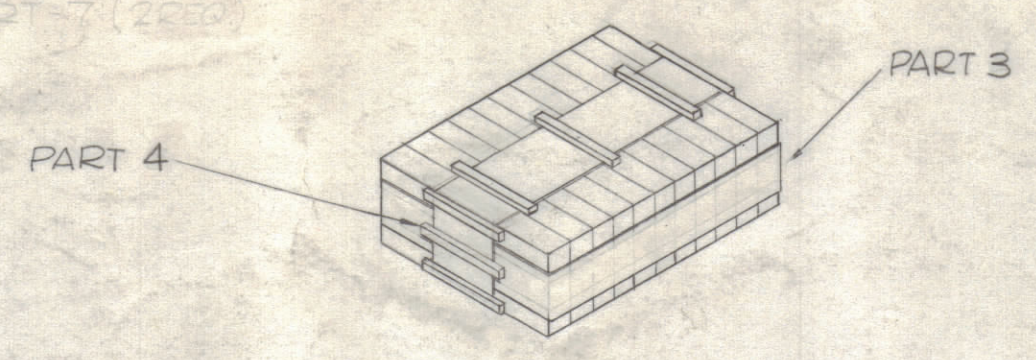

ATTACH PART 4 TO PART 3 AS SHOWN.

STEP-7

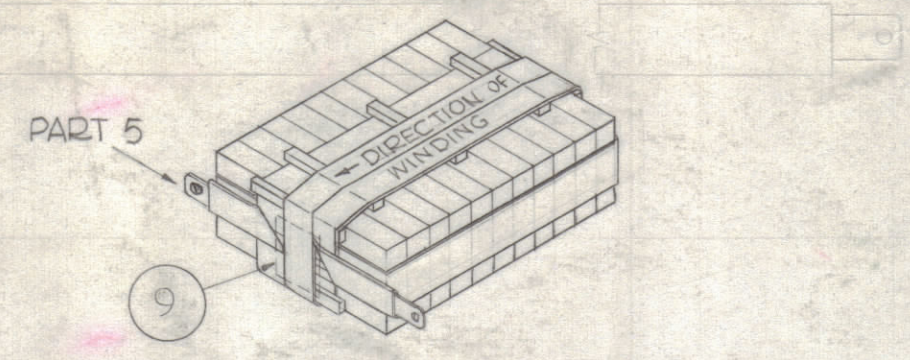

WIND 2 COMPLETE TURNS OF PART 5 OVER PART 4 & SECURE WITH A 6" STRIP OF ITEM 9 AS SHOWN.

STEP-8

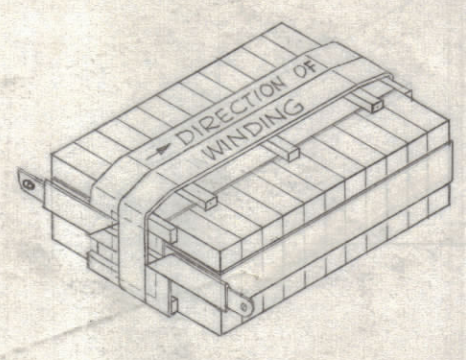

SAME AS STEP-7, ONLY, WIND PART 5 IN THE OPPOSITE DIRECTION.

STEPS- 9,10,11

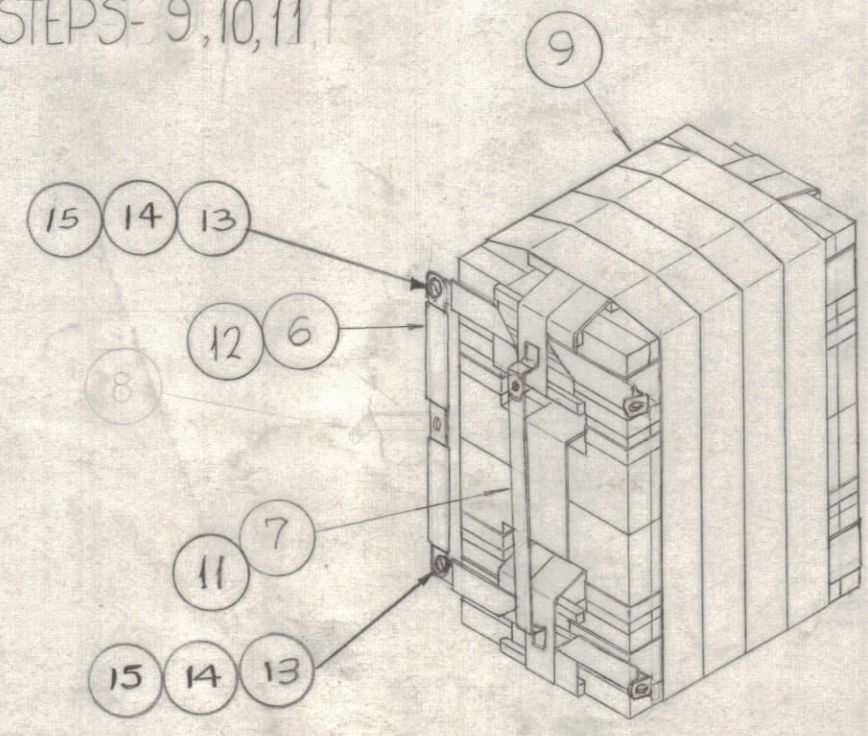

- ASSEMBLE STEPS 2,7,8 AND SECURE WITH 2 TURNS OF ITEM 9
- BOLT ITEM 6 TO PART 5 AS SHOWN
- SOLDER ITEM 7 BY TAPPING PART 5 AS SHOWN.
- SOLDER ITEM 8 TO PART 5 AS SHOWN.

NOT TO BE RELEASED
W/O AUTHORIZATION

AUTH-BY: _____
DATE: _____

NOTES

1	GPT-200K(AK-392)	A-3159
Q'TY./UNIT	MODEL USED ON	ASS'Y. NO.
SCALE	CODE	
	A	

THE CONTENTS OF THIS DRAWING ARE THE EXCLUSIVE PROPERTY OF THE TECHNICAL MATERIEL CORP. ITS UNAUTHORIZED USE OR REPRODUCTION IN WHOLE OR IN PART IS STRICTLY FORBIDDEN.

REVISIONS						
ZONE	SYM	DESCRIPTION	DATE	E.M.N. NO.	DRAFT	CHKD
		ORIGINAL RELEASE FOR PRODUCTION	3-6-64			
B5	A	STEPS 9,10 & 11; BOLT IT. 6 WAS "SOLDER IT. 6"	4-13-65	13884		
	B	IT. 13, 14, 15 ADDED	6/1/67	14162		



REQ'D.	ITEM	PART NUMBER	DESCRIPTION	SYMBOL
2	15	NTH1032BN12	NUT, PLAIN, HEX	
2	14	LWS10MRN	WASHER, LK, SPLIT	
2	13	SCBP1032BN7	SCR, MACHINE	
2	12	PX-370-50-7-2.500	INSULATION, SLEEVING, TEFLON	NATURAL
1	11	PX-370-50-7-7	INSULATION, SLEEVING, TEFLON	NATURAL
X	10	TA-108-5	TAPE, GLASS (14'-7")	
X	9	TA-108-9	TAPE, GLASS (40'-0")	
X	8	BS-100-	SOLDER, SOFT TO PLATE	
1	7	MS-3216	STRAP, CONNECTING	
1	6	MS-783-12-64-5	STRAP, COPPER	
1	5	MS-783-12-320-5	STRAP, COPPER	
1	4	PX-370-50-7-38	TEFLON, TUBING	
24	3	PX-615-1	SPACER, TEFLON	
66	2	CI-125-1-Q1	I CORES	
22	1	CI-101-5-Q1	C CORES.	

F. BUDETTI LIST OF MATERIAL				
THE TECHNICAL MATERIEL CORP. MAMARONECK, NEW YORK				
TITLE TR-180 ASS'Y				
MATERIAL		FINISH		
UNLESS OTHERWISE SPECIFIED DIMENSIONS ARE IN INCHES AND INCLUDE CHEMICALLY APPLIED OR PLATED FINISHES		DRAWN SRG DATE 6-25-63		
DECIMALS .X ± .05 .XX ± .01 .XXX ± .005		CHECKED aa gpb DATE 3/16-64		
FRACTIONS ± 1/64 ANGLES ± 0° 30'		MECH. DES. he DATE 3/16/64		
		FINAL APPROVAL DATE 4/22/64		
		SHEET A-3158		
		REV. LTR. B		

A-3158 B