

A-3239

THE CONTENTS OF THIS DRAWING ARE THE EXCLUSIVE PROPERTY OF THE TECHNICAL MATERIEL CORP. ITS UNAUTHORIZED USE OR REPRODUCTION IN WHOLE OR IN PART IS STRICTLY FORBIDDEN.

NOTE:
IF SHIMS ARE TO BE USED UPON ASS'Y,
LENGTH OF SHIM TO BE DETERMINED BY MFG.
FOR FIT OF PARTS INVOLVED.

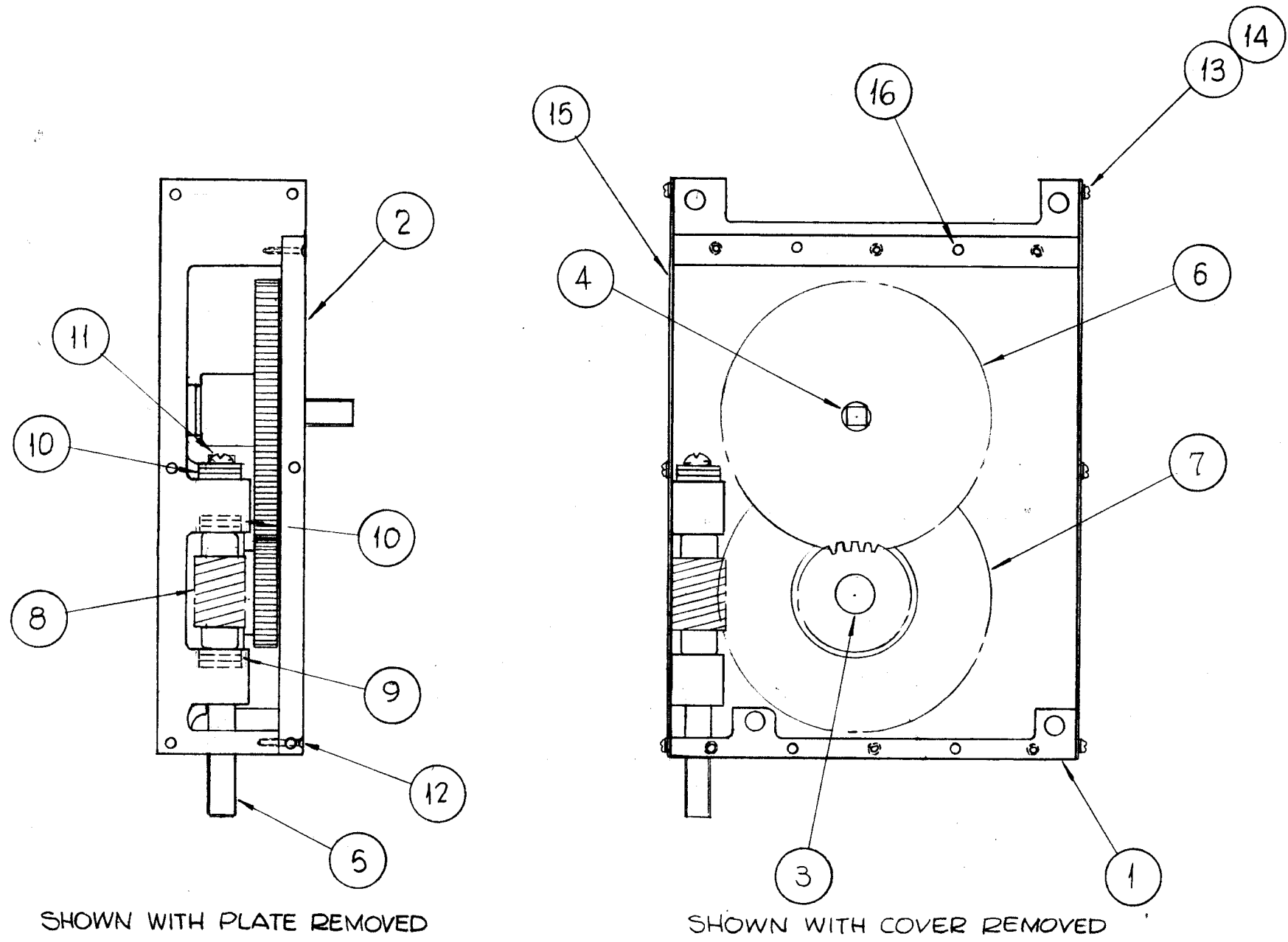

4	16	PN-116-M-4-5	PIN, DOWEL	
2	15	MS-3517	PLATE, SIDES	
12	14	LW504MRN	WASHER, LOCK, SPLIT	
12	13	SCBP0440BN3	SCREW, MACHINE	
6	12	SCBP0440BN9	SCREW, MACHINE	
1	11	SC-159-10325511	SCREW, NYLOCK, SOCKET HEAD, BUTTON	
2	10	BB-129-14	BEARING, RACE	
1	9	BB-129-15	BEARING, RACE	
1	8	GR-193-2	GEAR, WORM	
1	7	GR-193-1	GEAR, WORM & SPUR	
1	6	GR-194	GEAR, SPUR	
1	5	PM-948	SHAFT, CAP. GEAR BOX	
1	4	PM-947	SHAFT, CAP. GEAR BOX	
1	3	PM-944	SHAFT, CAP. GEAR BOX	
1	2	PM-924	PLATE, RETAINING	
1	1	PM-920	CAPACITOR GEAR BOX (LOAD)	

REQ.	ITEM	PART NO.	F. BUDETTI	DESCRIPTION	SYMBOL
STOCK SIZE			THE TECHNICAL MATERIEL CORP. MAMARONECK, NEW YORK		
MATERIAL					
CAP. GEAR BOX ASS'Y (LOAD)					
FINISH & SPEC. NO.			SRG	AA 9/8	RC 3-30-64
TYPE & TEMPER			HEAT TREAT. SPEC.	DRAWN	CHECKED
ELEC. DES. APP.			MECH. DES. APP.	FINAL APPROVAL	
A-3239			A-3239		0

0	ORIGINAL RELEASE FOR PRODUCTION	3-3-64				
SYM	DESCRIPTION	DATE	CH. NO.	DRAFTS	CHECKER	ENG. APP.
A	UNLESS OTHERWISE SPECIFIED: DIMENSIONS ARE IN INCHES TOLERANCES ON FRACTIONS ± 1/64 DECIMALS ± .005 ANGLES ± 1/2°	SCALE: 1/2	MAXIMUM ALLOWABLE TOLERANCES HAVE BEEN DETERMINED AND ANY DEVIATIONS WILL BE CAUSE FOR REJECTION. REMOVE ALL BURRS AND SHARP EDGES			
1	GPT-200K	AX-395	AX-3185	9-30-63		
REQ. PER UNIT	MODEL	SECTION	ASS'Y. NO.	DATE	USED ON	