

IF IT IS FOUND DESIRABLE TO CHANGE ANY TOLERANCE OR OTHER DETAIL SPECIFIED ON THIS DRAWING NOTIFY THE PURCHASER PROMPTLY.

MAXIMUM ALLOWABLE TOLERANCES HAVE BEEN DETERMINED AND DEVIATIONS WILL BE CAUSE FOR REJECTION. REMOVE ALL BURRS AND SHARP EDGES

FINISH:
 S-114 - ZINC CHROMATE PRIMER
 S-115 - SMOOTH GRAY ENAMEL
 DO NOT PAINT STUD END
 STAMPING AFTER PAINTING:
 BLACK GOTHIC AS SHOWN

A-473 A

ELECTRICAL TEST DATA

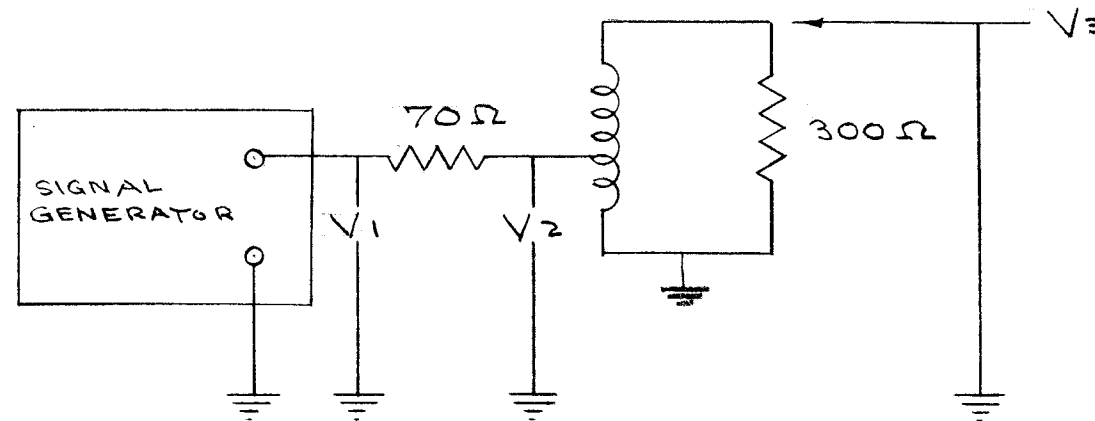

f. mc.	R. F. VOLTS *		
	V ₁	V ₂	V ₃
2	1.05	.47	.98
8	1.05	.52	1.00
32	1.05	.57	.96

* VOLTAGES MEASURED WITH H.P. VTVM.

TERMINALS 3 & 4
 CONNECTED INTERNALLY

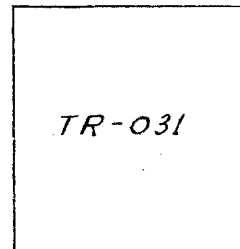
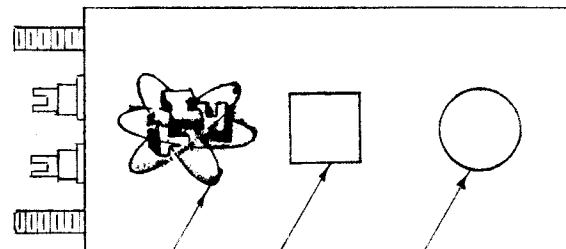
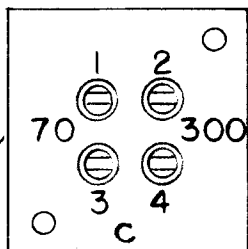

APPROVAL STAMP
 INSPECTION STAMP
 TMC INSIGNIA

FREQ. RANGE 2-30 MC ± 3db.
 70 Ω TO 300 Ω UNBALANCED

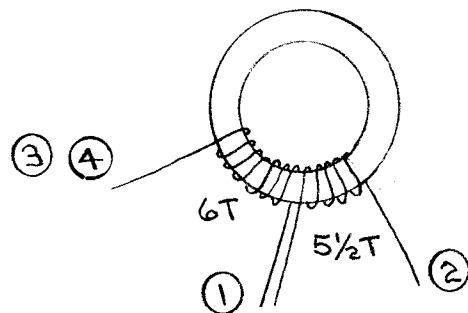

BOTH WINDINGS IN SAME DIRECTION.

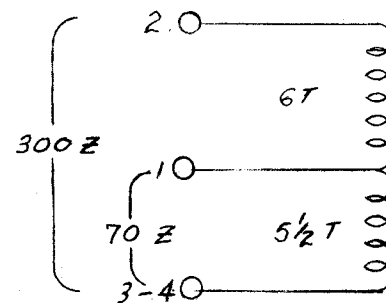

REQ.	ITEM	PART NO.	DESCRIPTION	SYMBOL
1	7	NP-117	TMC INSIGNIA	
X	6	WL-100-7	WIRE, BUSSBAR	
X	5	GL-100	POTTING COMPOUND	
X	4	BS-100	SOLDER, SOFT	
X	3	WI-102-9	WIRE	
1	2	CI-100-2	CORE	
1	1	BX-103	CASE, TRANSFORMER	

**NOT TO BE RELEASED
 W/O AUTHORIZATION**

AUTH. BY.....
 DATE:.....

ISSUE	ITEM	CHANGED FROM	DATE	CN. NO.	DRAFTS	CHECKER	ENG. APP.
A	1	STAMPING CLARIFIED	5/12/55	1	FAO	DDIS	WAL

TOLERANCES: DEC. DIM. ±, FRAC. DIM. ±, ANGULAR DIM. ±

SCALE: 1/16"

DRILL, PUNCH, COMMERCIAL STOCK SIZES AND MANUFACTURERS TOLERANCES ARE NOT INCLUDED.

MODEL	PROJECT NO.	ASS'Y. NO.	DATE

USED ON

REQ.	ITEM	PART NO.	DESCRIPTION	SYMBOL
THE TECHNICAL MATERIEL CORP. MAMARONECK, NEW YORK				
TRANSFORMER, ANT. MATCHING				
TR-031				
C.D.D. 5-22-53		ARB		
DRAWN		ELEC. DES. APP.		MECH. DES. APP.
CHECKED		FINAL APPROVAL		
				A-473 A