

REVISIONS							
E.M.N.NO	DRAFT	CHKD	ZONE	LTR	DESCRIPTION	DATE	APPROVED
	W			8	ORIGINAL RELEASE FOR PRODUCTION	1/7/72	

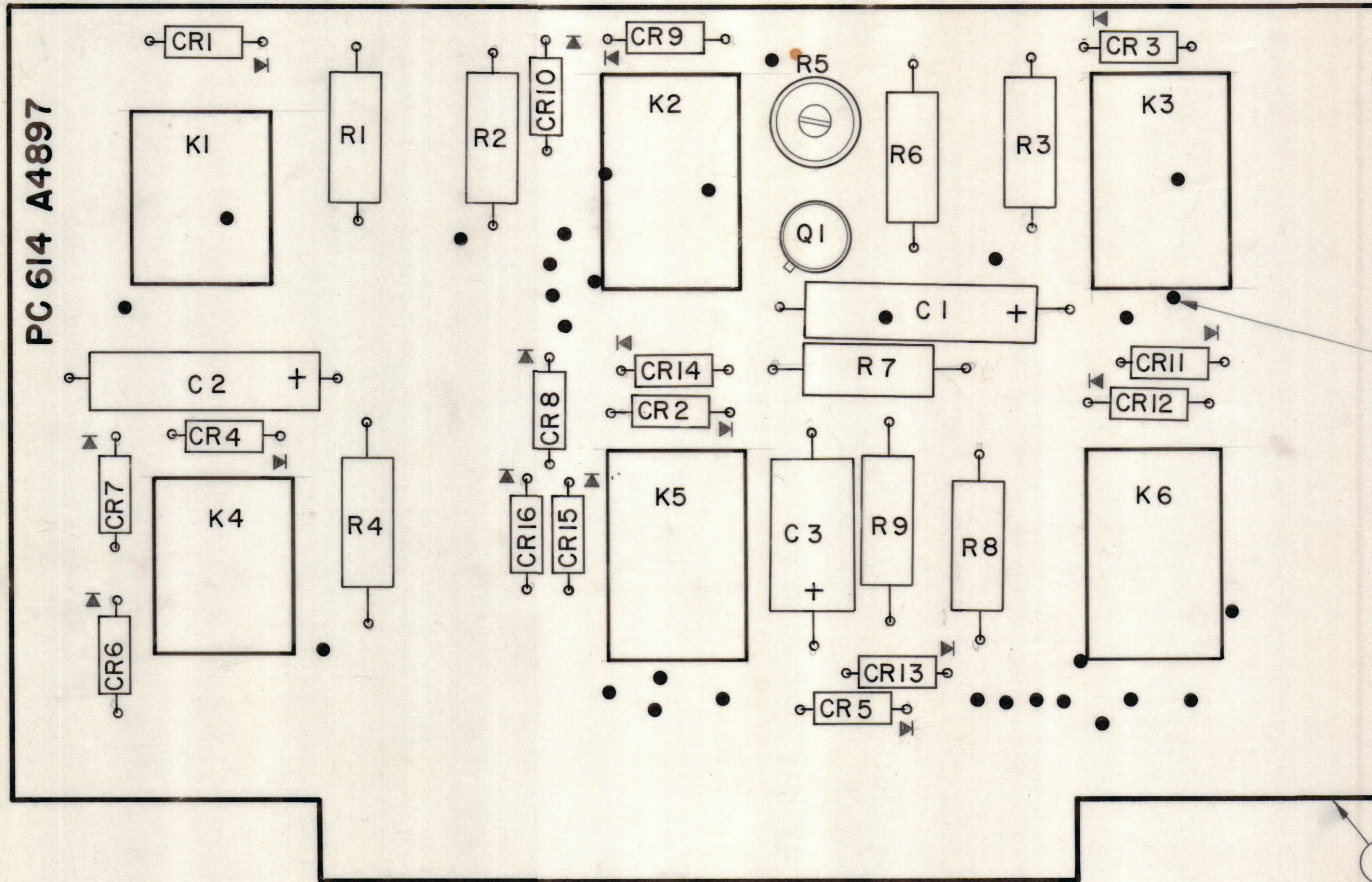

- ASSEMBLY NOTES
1. TO MOUNT COMPONENTS, INSERT LEADS THRU PLATED THRU-HOLES.
  2. CAUTION WHEN APPLYING HEAT AND SOLDER TO LEAD AND FOIL.
  3. CLEAN AND INSPECT AS PER TMC SPEC S676.
  4. FOR ELECTRICAL COMPONENT PART NUMBERS REFER TO NPL A-4897
  5. USE SYMBOL NUMBERS FOR ASSEMBLY REFERENCE.

QTY. REQ.	ITEM	PART NO.	DESCRIPTION	SYMBOL
X	3	BS 100	SOLDER TIN ALLOY	
X	2	WL 100-7	WIRE BUSS	
1	1	PC 614	PRINTED CIRCUIT BOARD	

LIST OF MATERIAL			
FINAL APPROVAL		DATE	<b>THE TECHNICAL MATERIEL CORP.</b> MAMARONECK, NEW YORK  ASSY. PRINTED CIRCUIT BOARD
MECH. DES.		DATE	
ELECT. DES.		DATE	
CHECKED		DATE	
DRAWN		DATE	
SIZE	CODE IDENT NO.	DWG NO.	ISSUE
C	82679	A4897	8
SCALE 2:1		SHEET OF	

RDCR-1YA		
QTY / UNIT	MODEL USED ON	ASS'Y NO.
APPLICATION		
CODE		
<small>NOTICE TO PERSONS RECEIVING THIS DRAWING</small> THE TECHNICAL MATERIEL CORPORATION claims proprietary right in the material disclosed herein. This drawing is issued in confidence for engineering information only and may not be reproduced or used to manufacture anything shown herein without permission from THE TECHNICAL MATERIEL CORPORATION to the user. This drawing is loaned for mutual assistance and is subject to recall at any time.		