

IF IT IS FOUND DESIRABLE TO CHANGE ANY TOLERANCE OR OTHER DETAIL SPECIFIED ON THIS DRAWING NOTIFY THE PURCHASER PROMPTLY.

MAXIMUM ALLOWABLE TOLERANCES HAVE BEEN DETERMINED AND DEVIATIONS WILL BE CAUSE FOR REJECTION. REMOVE ALL BURRS AND SHARP EDGES

A-641 C

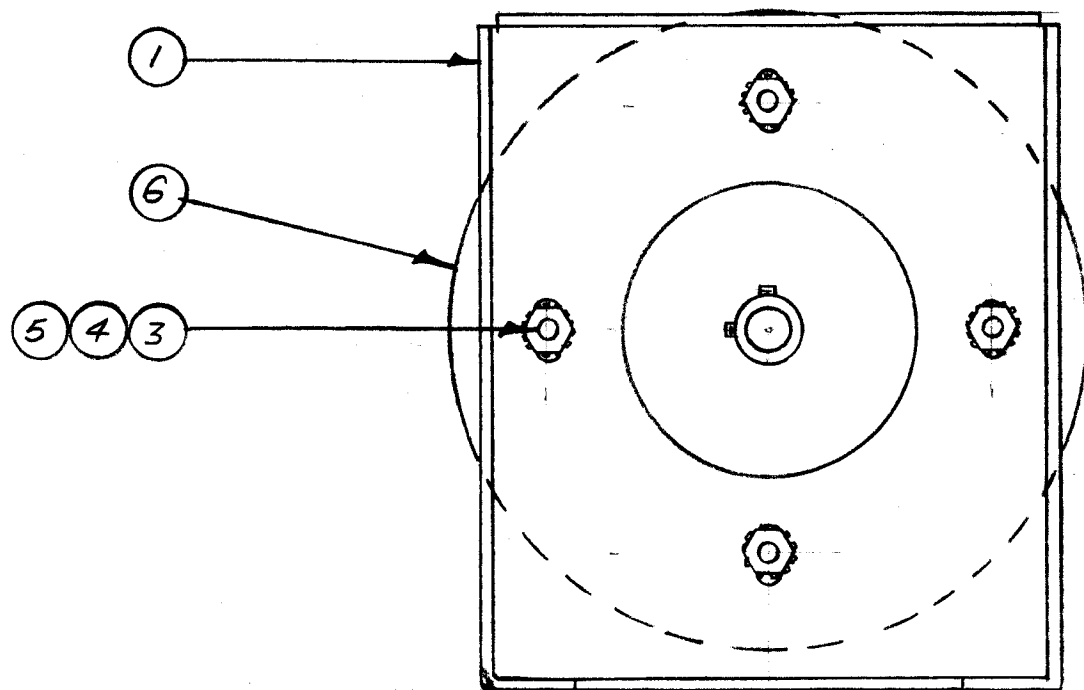
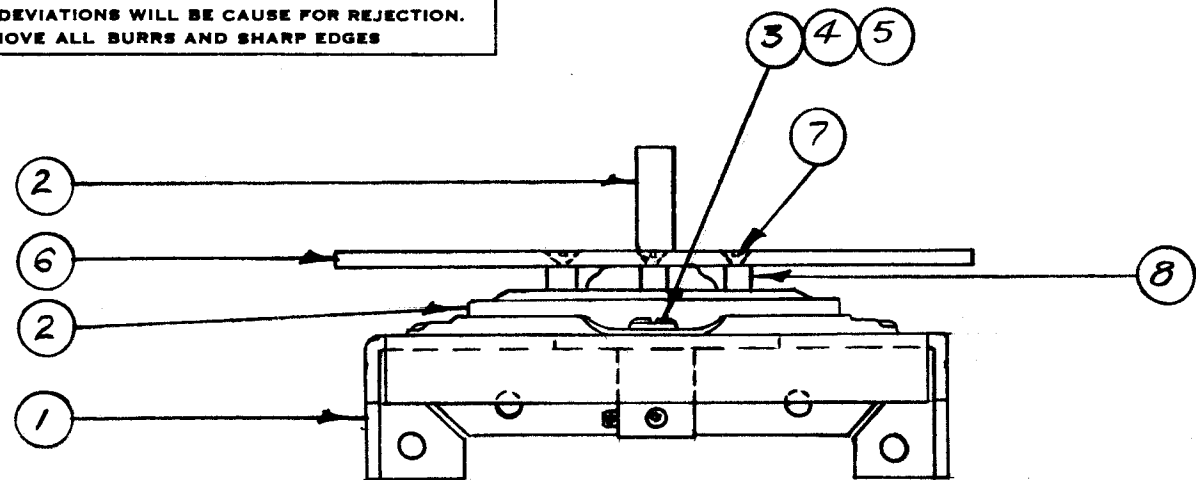

REQ.	ITEM	PART NO.	DESCRIPTION	SYMBOL
3	8	TE-117-21	STAND-OFF SPACER	
3	7	SCFP0440BN7	SCREW, MACH.	
1	6	NP-112	DIAL, RADIO FREQ.	
4	5	NTH0632BN8	NUT, HEX.	
4	4	LWE06MRN	LOCKWASHER, EXT.	
4	3	SCBP0632BN4	SCREW, MACH.	
1	2	PO-102	VERNIER DIAL MECHANISM	
1	1	MS-224	DIAL MOUNTING BRACKET	

THE TECHNICAL MATERIEL CORP. MAMARONECK. NEW YORK			
DIAL, BRACKET & VERNIER SUB-ASS'Y. XFK			
101-12-54	AJT	WJE	
DRAWN		ELEC. DES. APP.	MECH. DES. APP.
CHECKED		FINAL APPROVAL	
		A-641 C	

ISSUE	ITEM	CHANGED FROM	DATE	CN. NO.	DRAFTS	CHECKER	ENG. APP.
C		IT. 7 WAS SCFS0440BN7	11/11/66	17223	RME	[Signature]	[Signature]
B	2	Item 3 Was SCBS0632BC4	12-26-61	6097	GG	[Signature]	[Signature]
A	1	All Hardware Was Cadmium					
		ITEM 7 WAS SCFS0440B06	12/13/66	1	P.B.	[Signature]	[Signature]

TOLERANCES		SCALE: $\frac{1}{2}$
ALL OTHERS	DEC. DIM. \pm FRAC. DIM. \pm ANGULAR DIM. \pm	DRILL, PUNCH, COMMERCIAL STOCK SIZES AND MANUFACTURERS TOLERANCES ARE NOT INCLUDED.

1	XFK	A-684 (Pg. 1 of 3)	1-12-57
AMT. PER UNIT	MODEL	PROJECT NO.	ASS'Y. NO.
		DATE	
USED ON			