

A-665-1

28 DRILL - 4 HOLES

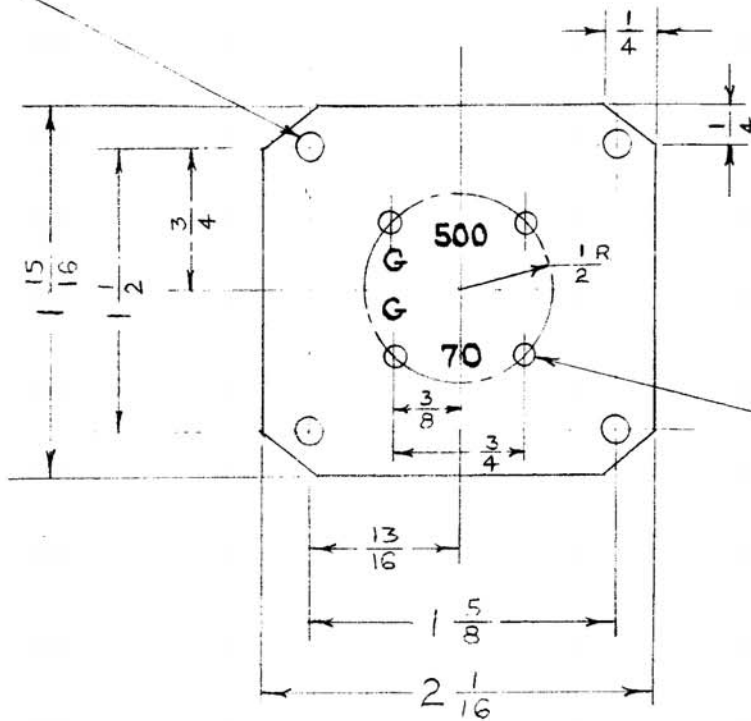

29 DRILL - 4 HOLES
 CTC X 1783D
 OR EQUIVALENT

**NOT TO BE RELEASED
 W/O AUTHORIZATION**

AUTH. BY.....
 DATE:.....

WAS AMM036
 1/29/54

MATERIAL: $\frac{1}{8}$ THK. XXXP LAMINATED PHENOLIC. JOB 153

DATE 9 - 8 - 52	TERMINAL BOARD TR-018	THE TECHNICAL MATERIEL CORPORATION MAMARONECK, NEW YORK SHEET 1 OF 3 NO. A-665	
DRN. <i>L. Gabel</i>			
CHKD. <i>APP</i>			
APPD. <i>TH</i>			

A-665-2

CORE: FERAMIC 109 H
WIRE: #30 COTENAMEL

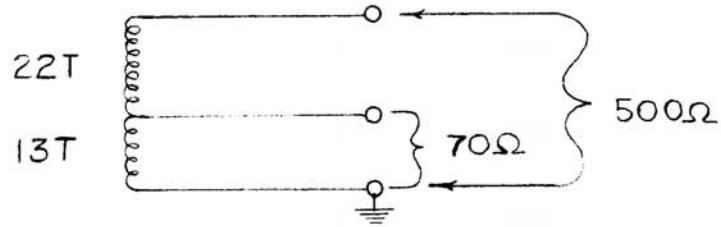

70 OHMS UNBALANCED TO 500 OHMS UNBALANCED

**NOT TO BE RELEASED
W/O AUTHORIZATION**

AUTH. BY.....

DATE:.....

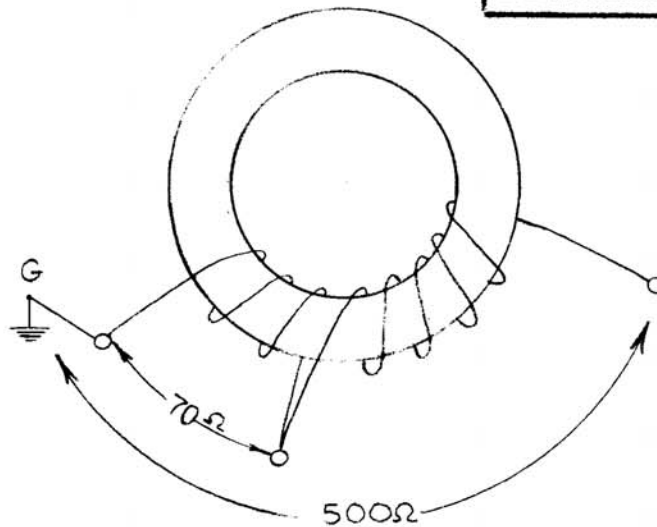

WAS AEM 105
1/29/54

REF. DWG. # : USE STANDARD ANTENNA
COUPLER COMBINER DOT IN WAX COIL-
POUND, Suspend coil with cord.

JOB 153

DATE 9-8-52	WINDING DATA TR-018	THE TECHNICAL MATERIEL CORPORATION MAMARONECK, NEW YORK	
DRN. <i>L. Gabel</i>			
CHKD. <i>APP</i>			
APPD. <i>RT</i>			

A-665-3

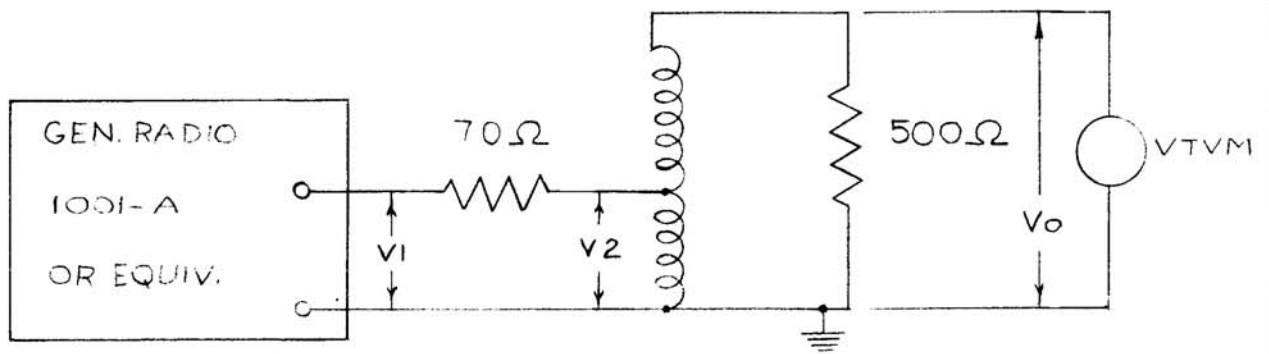

FREQ. MC	V_1 (VOLTS)	V_2 (VOLTS)	V_o (VOLTS)
500	.72	.36	.88
1000	.72	.36	.89
2000	.72	.38	.88

**NOT TO BE RELEASED
W/O AUTHORIZATION**

AUTH. BY.....

DATE:.....

was AE3046
1/29/54

JOB 153

DATE 9-8-52	TEST DATA TR-018	THE TECHNICAL MATERIEL CORPORATION MAMARONECK, NEW YORK	
DRN. <i>L. Sab...</i>			
CHKD. <i>MPB</i>		SHEET 3 OF 3	NO. A-665
APPD. <i>PH</i>			