

IF IT IS FOUND DESIRABLE TO CHANGE ANY TOLERANCE OR OTHER DETAIL SPECIFIED ON THIS DRAWING NOTIFY THE PURCHASER PROMPTLY.

MAXIMUM ALLOWABLE TOLERANCES HAVE BEEN DETERMINED AND DEVIATIONS WILL BE CAUSE FOR REJECTION. REMOVE ALL BURRS AND SHARP EDGES

NICK 2 CORNERS
V16

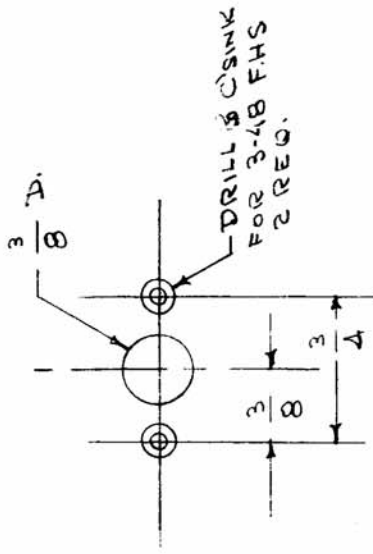
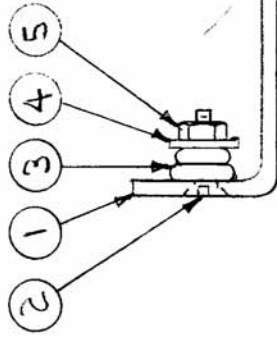
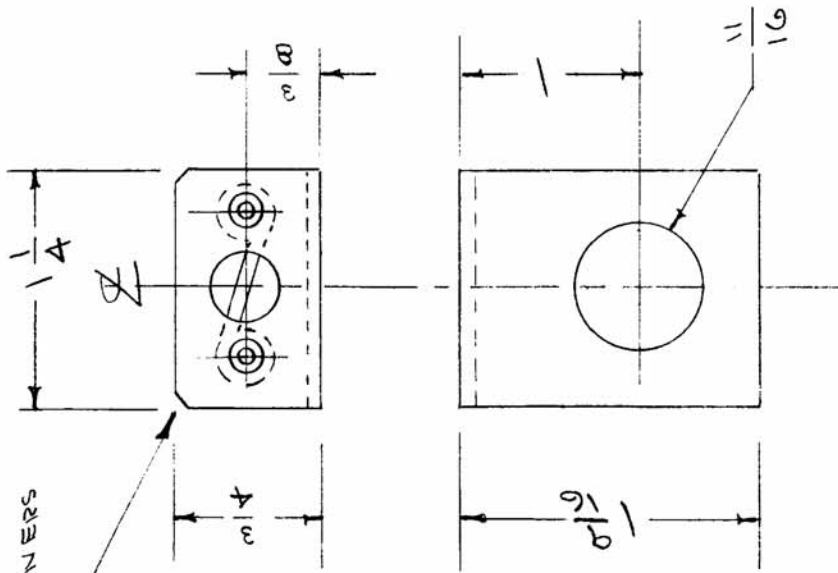

A-824 A

REQ PER UNIT
PROJECT NO.
ASSY. NO.
DATE

REQ. ITEM	PART NO.	DESCRIPTION	SYMBOL
1	5 NTH0342BC6	NUT, HEX	
1	1 LWS03MRC	WASHER, LOCK	
1	3 FS-102-1	SPRING, "S" TYPE	
1	2 SCFS0342BC4	SCREW, MACHINE	
1	1 MS-562	BRACKET, (NO DWG)	

THE TECHNICAL MATERIEL CORP.
MAMARONECK, NEW YORK
BRACKET ASSY., COVER

ALUMINUM	STOCK SIZE	WEIGHT PER PC.
52 S-H-32		
TYPE & TEMPER		
H		
HEAT TREAT. SPEC.		
S404 IRIDITE		
FINISH & SPEC. NO.		

ISSUE ITEM	CHANGED FROM	DATE	CN. NO.	DRAFTS	CHECKER	ENG. APP.
A 1	FIN: S404 IRIDITE WAS CAUSTIC DIP	12-4 59	1001	P	EMN	
TOLERANCES						
SCALE						
DRILL, PUNCH, COMMERCIAL STOCK SIZES AND MANUFACTURERS TOLERANCES ARE NOT INCLUDED.						
ALL OTHERS	DEC. DIM. ± 1/64 FRAC. DIM. ± 1/64 ANGULAR DIM. ±					

THE TECHNICAL MATERIEL CORP.
MAMARONECK, NEW YORK
BRACKET ASSY., COVER

CO.D. 9/11/54
DRAWN KZ
ELEC. DES. APP. WSC
MECH. DES. APP.
CHECKED AJT
FINAL APPROVAL

A-824 A