

4

3

2

1

REVISIONS						
ZONE	LTR	DESCRIPTION	DATE	E.M.N.NO	DRAFT	CHKD APPD
	X	DWG. No WAS 40N12C7162	8/15/69		CG	
	Ø	ORIGINAL RELEASE FOR PRODUCTION	8/25/69		CG	

NOTES:

- 1-PURCHASED FROM TMC, MAMARONECK, N.Y.
- 2-HERMAN H. SMITH INC, BROOKLYN, N.Y. 11207

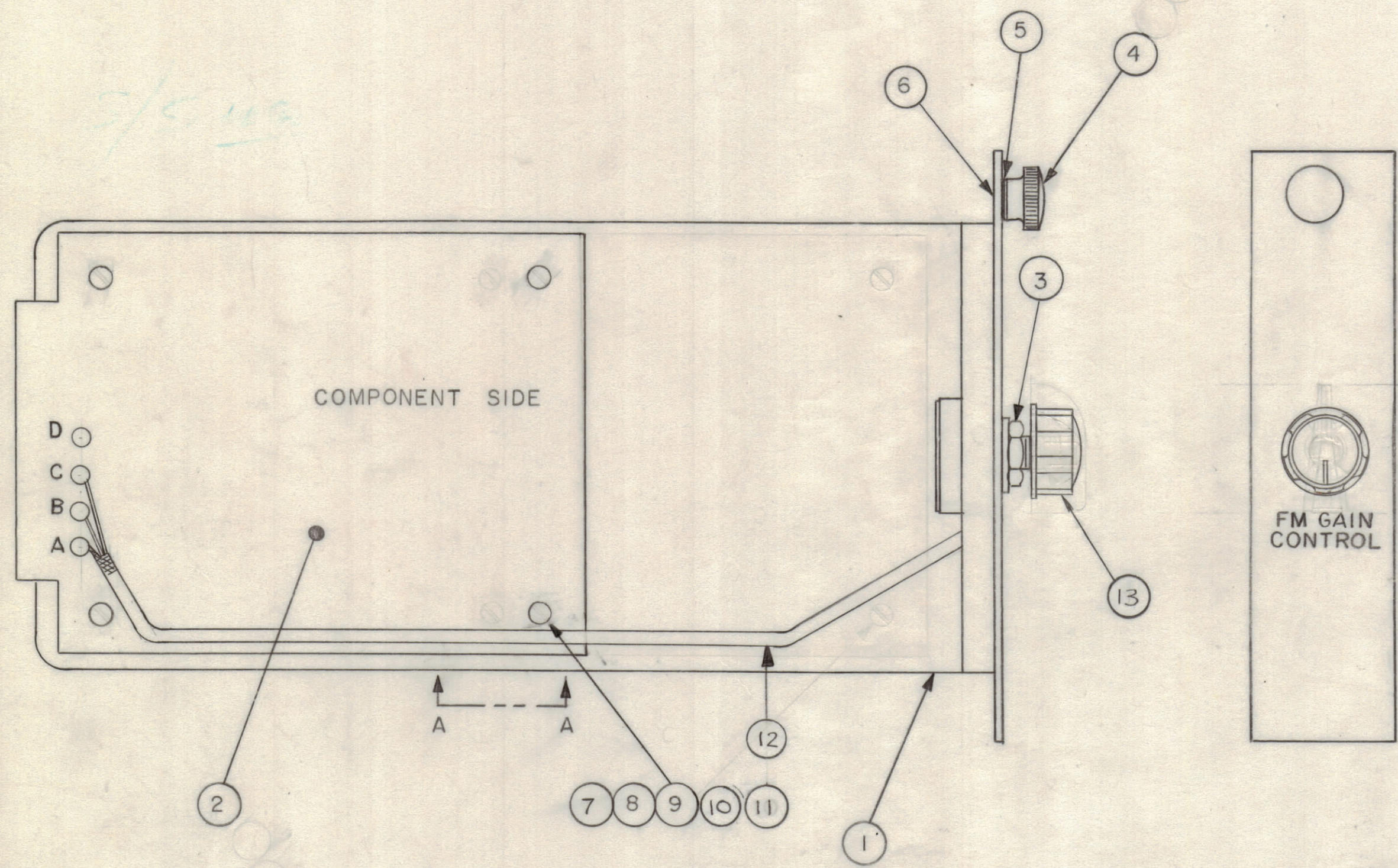

QTY. REQ.	ITEM	PART NO.	DESCRIPTION	SYMBOL
1	13	MP123-UB	KNOB	
X	12	RG188A/U	CABLE, SUBMINIAX	
1	11	NTH0440BNS	NUT	
1	10	LWE04MRC	WASHER	
4	9	FW04HBN	WASHER	
4	8	TE117-28	SPACER	
4	7	SCFP0440BNS	SCREW, FLAT HD.	
1	6	SCFP0632BNG	SCREW FLAT HD.	
1	5	FW08HBN	WASHER FLAT	
1	4	MP10004-1	KNOB	
1	3	RV4NAYS502A	POTENTIOMETER 5K/2W/	RI7
1	2	A8060	PC ASSEMBLY	
1	1	LD8072-1/MS83724	MODULE CHASSIS	

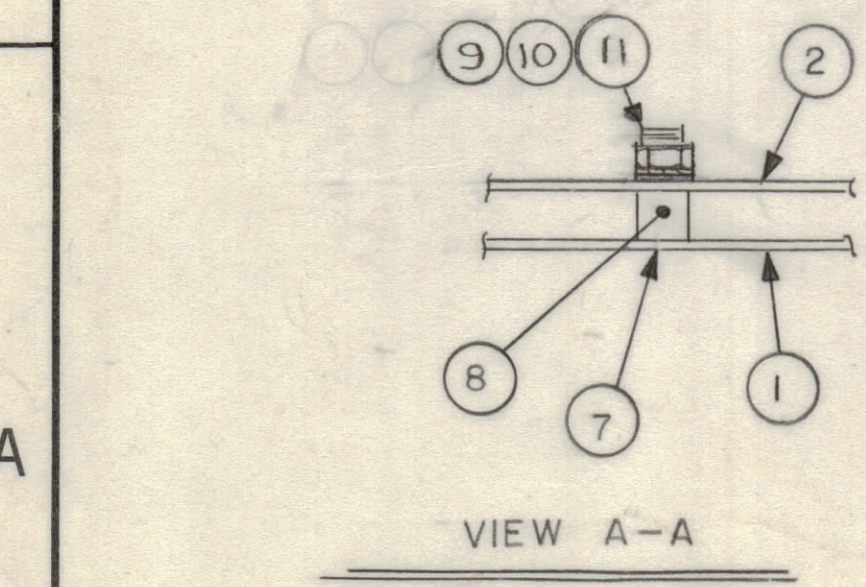

2	SPT-3KVHF	AX 8026
QTY / UNIT	MODEL USED ON	ASS'Y NO.
APPLICATION		
CODE		

NOTICE TO PERSONS RECEIVING THIS DRAWING

THE TECHNICAL MATERIEL CORPORATION claims proprietary right in the material disclosed hereon. This drawing is issued in confidence for engineering information only and may not be reproduced or used to manufacture anything shown hereon without permission from THE TECHNICAL MATERIEL CORPORATION to the user. This drawing is loaned for mutual assistance and is subject to recall at any time.

UNLESS OTHERWISE SPECIFIED DIMENSIONS ARE IN INCHES AND INCLUDE CHEMICALLY APPLIED OR PLATED FINISHES		FINAL APPROVAL J.F.P. 8/13/69	DATE 7-1-68
TOLERANCES ON		MECH. DES. J.F.P.	DATE 6-15-68
DECIMALS	FRACTIONS	ELECT. DES. [Signature]	DATE 8/13/69
.X ± .05	± 1/64	CHECKED J.F.P.	DATE 6-15-68
.XX ± .01	ANGLES	DRAWN CB	DATE 6/15/68
.XXX ± .005	± 0° -30'		

LIST OF MATERIAL			
THE TECHNICAL MATERIEL CORP. MAMARONECK, NEW YORK			
ASSEMBLY FM PROCESSING AMPLIFIER AX8031			
SIZE	CODE IDENT.NO.	DWG NO.	ISSUE
C	82679	40 A8085	Ø
SCALE			SHEET 1 OF 1

4

3

2

1