

REVISIONS							
ZONE	SYM	DESCRIPTION	DATE	E.M.N. NO.	DRAFT	CHKD	APPD

NOTICE TO PERSONS RECEIVING THIS DRAWING

THE TECHNICAL MATERIEL CORPORATION claims proprietary right in the material disclosed hereon. This drawing is issued in confidence for engineering information only and may not be reproduced or used to manufacture anything shown hereon without permission from THE TECHNICAL MATERIEL CORPORATION to the user. This drawing is loaned for mutual assistance and is subject to recall at any time.

Property of:
 THE TECHNICAL MATERIEL CORPORATION
 MAMARONECK, NEW YORK

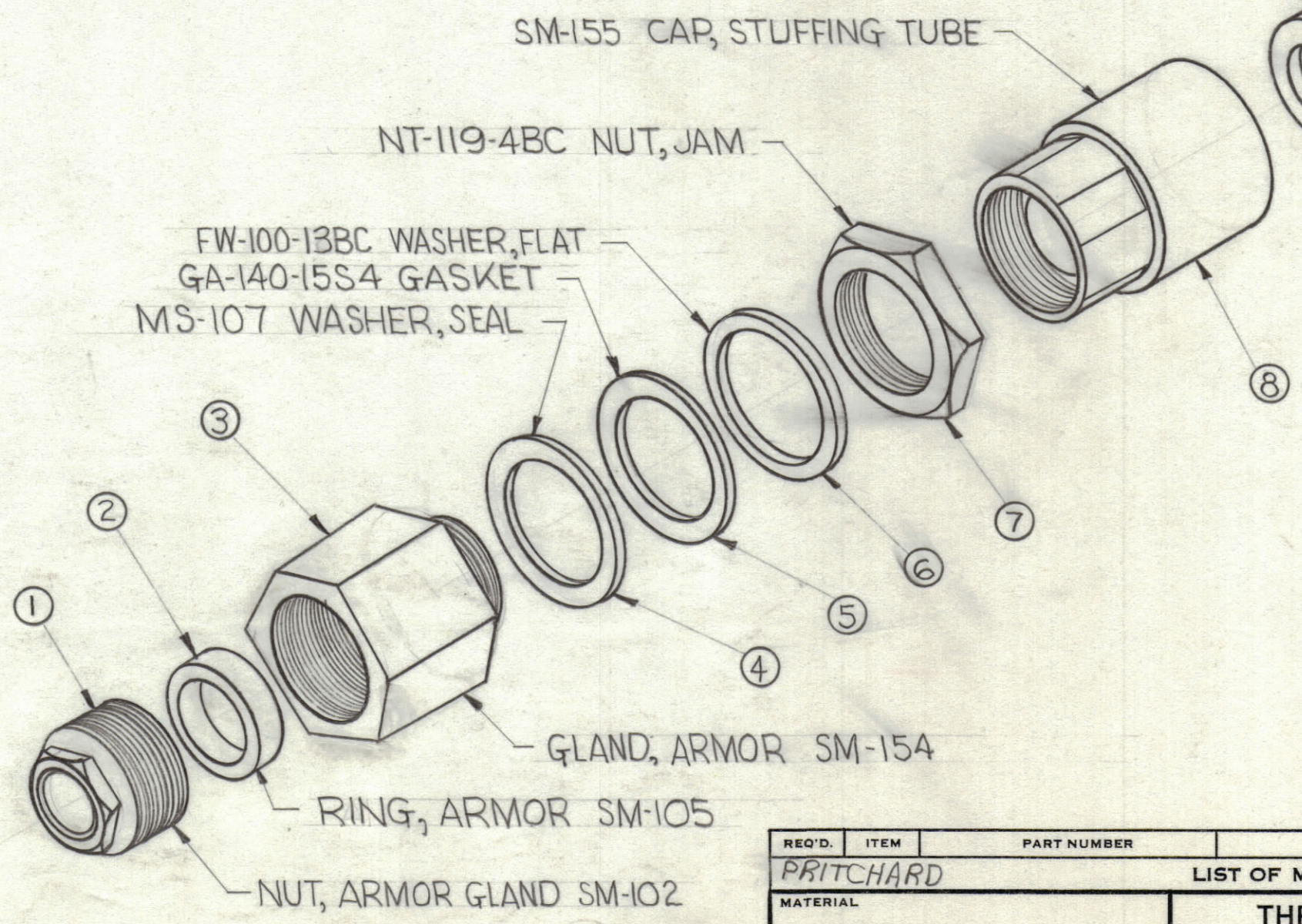
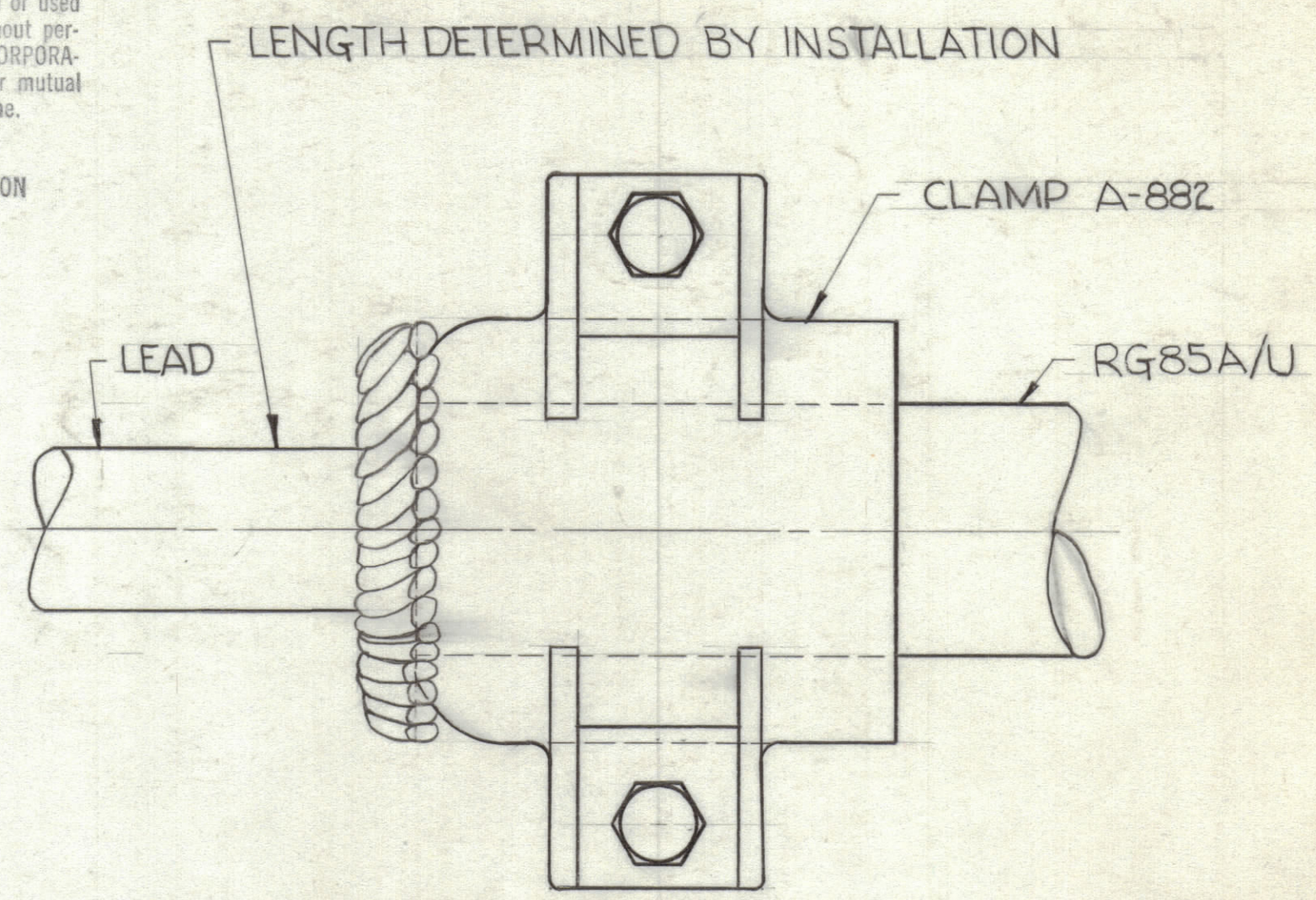
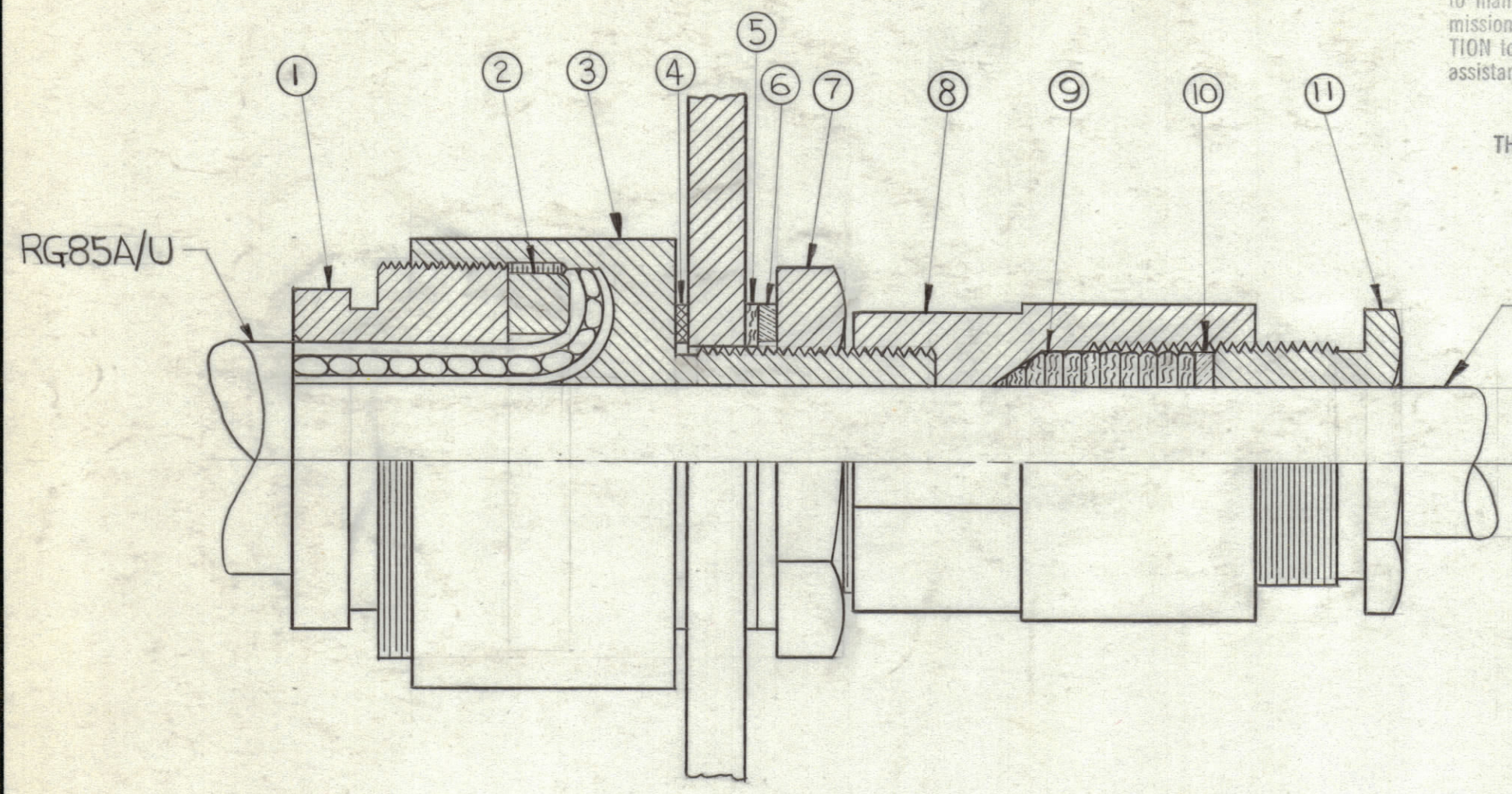

- ASSEMBLING ADAPTOR: GLAND STUFFING TUBE RG85/U**
- OPERATION:**
- (a) PLACE ARMOR GLAND NUT OVER RG85/U CABLE.
 (b) PLACE ARMOR RING OVER RG85/U CABLE, TO A DISTANCE OF APPROXIMATELY 11 INCHES FROM THE END OF CABLE.
 - (a) CUT END OF CABLE SQUARE AND CLEAN.
 (b) CLAMP BOTH HALVES OF FORMING CLAMP, TMC PART A-882, AROUND OUTER ARMOR OF RG85/U CABLE, AT DISTANCE OF 7 INCHES FROM END OF CABLE.
 (c) BEND OUTER ARMOR TO FORM FLARE AS SHOWN ON DETAIL SKETCH.
 (d) AFTER FORMING FLARE INTO TRUE RADIUS OF 5/16" (INSIDE RADIUS), NIP OFF ARMOR WIRES.
 (e) GRIND OFF ALL ROUGH EDGES OF ARMOR WIRE FLARE TO A SMOOTH SURFACE, BEING CAREFUL TO MAINTAIN TRUE OUTSIDE DIAMETER OF APPROXIMATELY 1/32 OF AN INCH LESS THAN 2-5/8 INCHES IN DIAMETER.
 (f) REMOVE CLAMPS.
 - (a) ASSEMBLE ARMOR COUPLING GLAND ARMOR RING AND ARMOR GLAND NUT, MAKING SURE ASSEMBLY IS TIGHT.

NOTE:

- IT IS RECOMMENDED THAT A SEALING COMPOUND SIMILAR TO DOW CORNING COMPOUND #4 OR GLYPTOL NO. 1202 BE USED FOR COATING THE THREADS IN ASSEMBLING THE FITTINGS AND ADAPTORS OF THE END SEALS.

AX-354

1	AX-354	
Q'TY./UNIT	MODEL USED ON	ASS'Y. NO.
SCALE	CODE	
DO NOT SCALE		
THE CONTENTS OF THIS DRAWING ARE THE EXCLUSIVE PROPERTY OF THE TECHNICAL MATERIEL CORP. ITS UNAUTHORIZED USE OR REPRODUCTION IN WHOLE OR IN PART IS STRICTLY FORBIDDEN.		

REQ'D.	ITEM	PART NUMBER	DESCRIPTION	SYMBOL
PRITCHARD LIST OF MATERIAL				
MATERIAL		THE TECHNICAL MATERIEL CORP. MAMARONECK, NEW YORK		
FINISH		TITLE ADAPTOR, GLAND STUFFING TUBE RG85/U		
DRAWN	R. Lurchin	DATE	6-12-62	FINAL APPROVAL
CHECKED	A. J. ...	DATE		
ELECT. DES.		DATE		
MECH. DES.	A. J. ...	DATE	6/27/62	
AX-354				SHEET
				REV. LTR.

NOTES