

NOTES:

1 TO FIT INSIDE COVER

2- MATERIAL 22 GAUGE (.028) COLD ROLLED STEEL.

3- BASE -HOT TIN DIP
COVER - HOT TIN DIP
ZINC CHROMATE PRIMER (S114)
SMOOTH GRAY ENAMEL (S115)

29 DRILL (.136)
INSTALL FUSITE
104-SW TERMINAL
(A-2637) (TYP 4 PL)

4-40NC X 3/8
STAINLESS STEEL STUD
SILVER SOLDER (TYP 4 PL)

DRILL & TAP FOR
6-32
(3 HOLES)

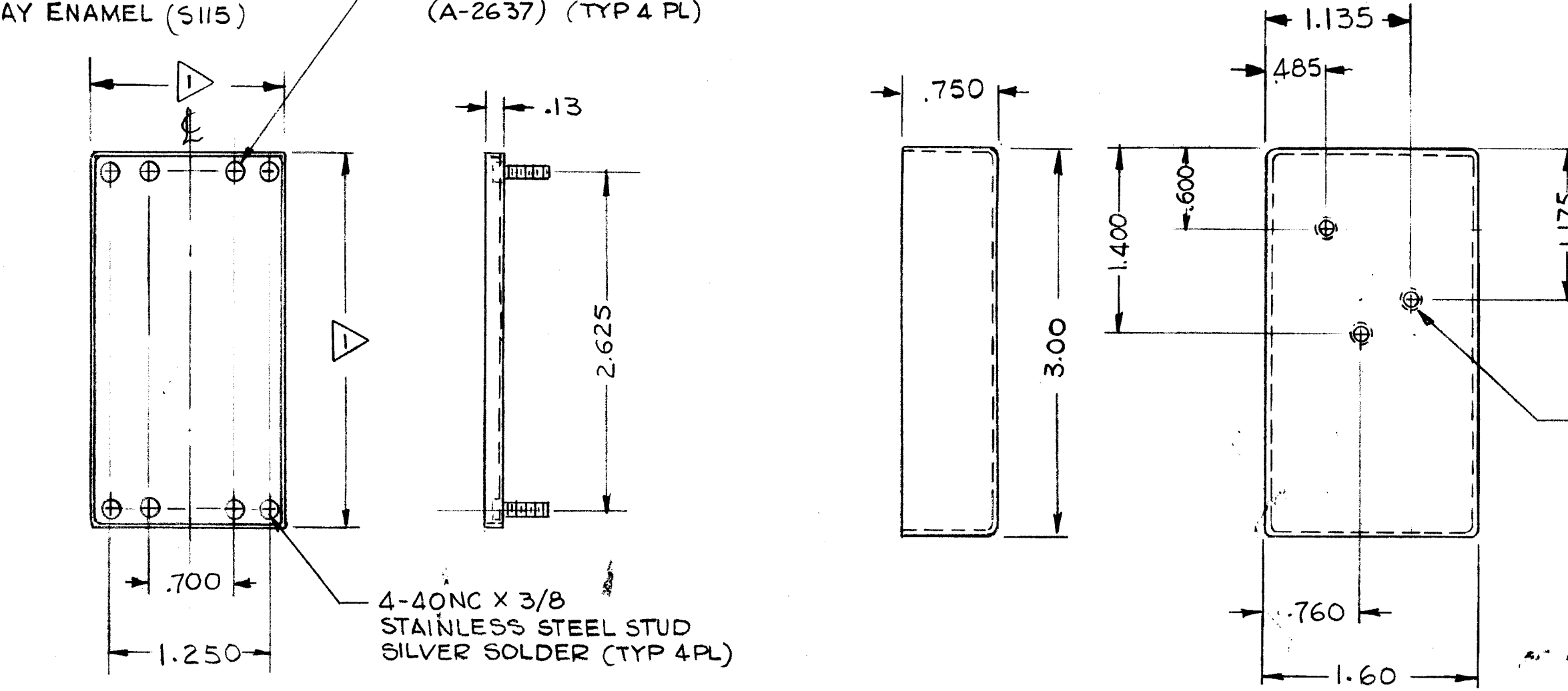

REVISIONS							
E.M.N. NO.	DRAFT	CHKD	ZONE	LTR	DESCRIPTION	DATE	APPROVED
	CL			Ø	ORIGINAL RELEASED FOR PRODUCTION	9/2/75	

REQ'D	ITEM	PART NUMBER	DESCRIPTION	SYM.
-------	------	-------------	-------------	------

LIST OF MATERIAL

THE TECHNICAL MATERIEL CORP.
MAMARONECK, NEW YORK

BASE AND COVER

QTY / UNIT	MODEL USED ON	ASS'Y NO.
APPLICATION		
CODE		

UNLESS OTHERWISE SPECIFIED DIMENSIONS ARE IN INCHES AND INCLUDE CHEMICALLY APPLIED OR PLATED FINISHES		FINAL APPROVAL <i>[Signature]</i>	DATE
DECIMALS .X ± .05 .XX ± .01 .XXX ± .005		ELECT. DES.	DATE
FRACTIONS 1/64 ANGLES 0° .30'		CHECKED <i>[Signature]</i>	DATE 8-11-71
MATERIAL		DRAWN G.D.L.	DATE 8-1-71
FINISH			

NOTICE TO PERSONS RECEIVING THIS DRAWING
THE TECHNICAL MATERIEL CORPORATION claims proprietary right in the material disclosed hereon. This drawing is issued in confidence for engineering information only and may not be reproduced or used to manufacture anything shown hereon without permission from THE TECHNICAL MATERIEL CORPORATION to the user. This drawing is loaned for mutual assistance and is subject to recall at any time.

SIZE B	CODE IDENT. NO. 82679	DWG NO. BX 235	ISSUE Ø
SCALE 1:1		SHEET OF	