

4

3

2

1

REVISIONS						
ZONE	LTR	DESCRIPTION	DATE	E.M.N.NO	DRAFT	CHKD APPD
	X	EXPERIMENTAL RELEASE	11-2-67	-		
	Ø	ORIG. RELEASE	11-3-67			
	A	PICTORIALS CLARIFIED	10-7-68	19064		FB

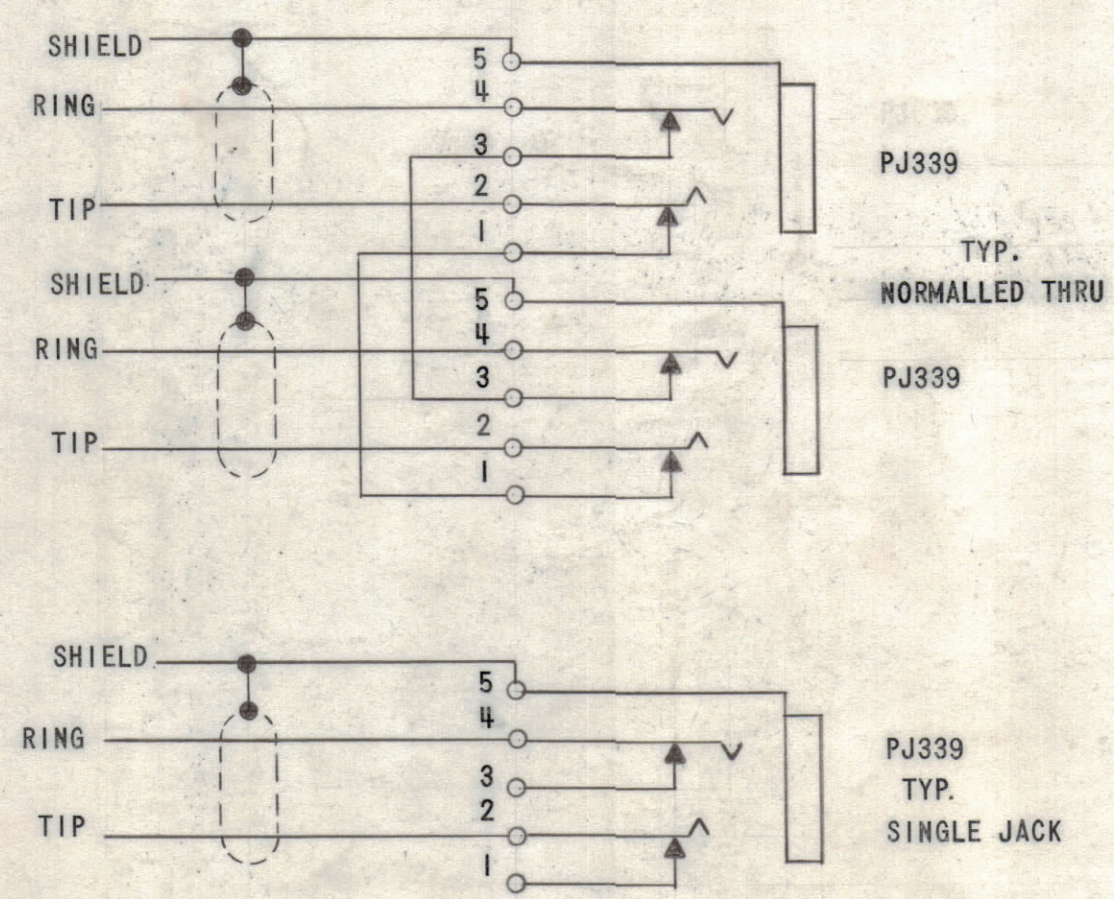
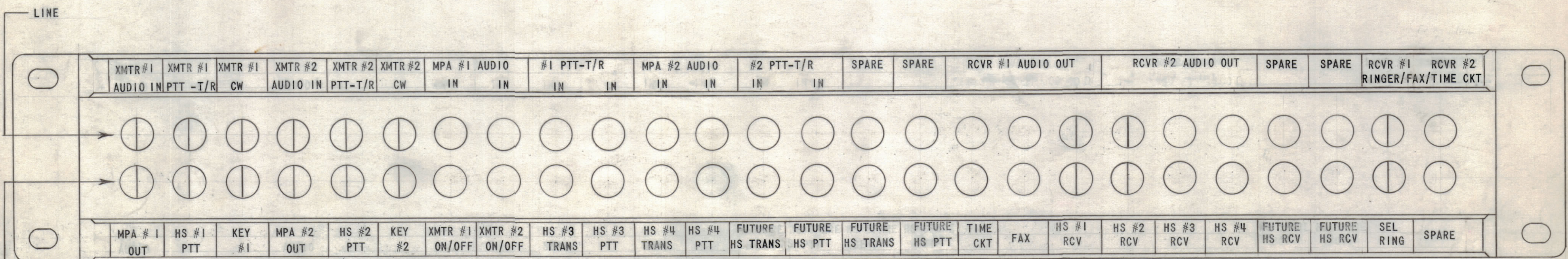

NOTE  
INDICATES  
NORMALLED  
THRU

1	RAK-75-6B	
QTY / UNIT	MODEL USED ON	ASS'Y NO.
APPLICATION		
CODE		

NOTICE TO PERSONS RECEIVING THIS DRAWING  
THE TECHNICAL MATERIEL CORPORATION claims proprietary right in the material disclosed hereon. This drawing is issued in confidence for engineering information only and may not be reproduced or used to manufacture anything shown hereon without permission from THE TECHNICAL MATERIEL CORPORATION to the user. This drawing is loaned for mutual assistance and is subject to recall at any time.

UNLESS OTHERWISE SPECIFIED  
DIMENSIONS ARE IN INCHES  
AND INCLUDE CHEMICALLY APPLIED  
OR PLATED FINISHES

TOLERANCES ON

DECIMALS	FRACTIONS
.X ± .05	± 1/64
.XX ± .01	ANGLES
.XXX ± .005	± 0° -30'

QTY. REQ.	ITEM	PART NO.	DESCRIPTION	SYMBOL
M. STURMER LIST OF MATERIAL				
FINAL APPROVAL		DATE	<b>THE TECHNICAL MATERIEL CORP.</b> MAMARONECK, NEW YORK  <b>PATCHFIELD WIRING DIAGRAM</b> FOR AVONDALE SHIPYARDS, INC.	
MECH. DES.		DATE		
ELECT. DES.		DATE		
CHECKED		DATE		
DRAWN		DATE		
MATERIAL		M/L	SIZE	CODE IDENT. NO.
FINISH			C	82679
			DWG NO.	ISSUE
			CK 1423	A
			SCALE	SHEET OF

4

3

2

1

CK1423 4 B