

IF IT IS FOUND DESIRABLE TO CHANGE ANY TOLERANCE OR OTHER DETAIL SPECIFIED ON THIS DRAWING NOTIFY THE PURCHASER PROMPTLY.

MAXIMUM ALLOWABLE TOLERANCES HAVE BEEN DETERMINED AND DEVIATIONS WILL BE CAUSE FOR REJECTION. REMOVE ALL BURRS AND SHARP EDGES

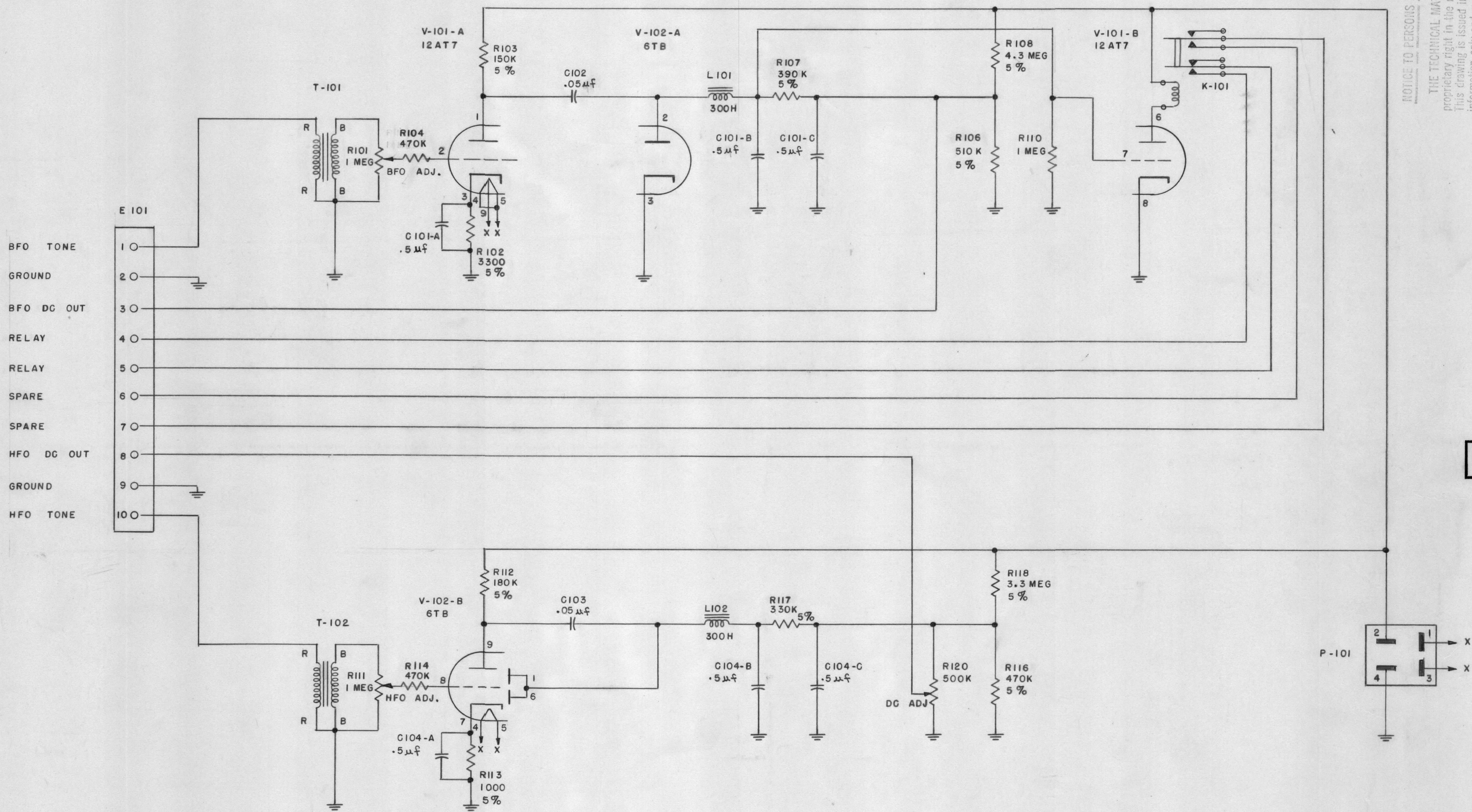

ALL RESISTORS ARE 1/2W, ±10% COMP. UNLESS OTHERWISE SPECIFIED.

NOTICE TO PERSONS RECEIVING THIS DRAWING  
 THE TECHNICAL MATERIEL CORPORATION claims proprietary right in the material disclosed hereon. This drawing is issued in confidence for engineering information only and may not be reproduced or used to manufacture anything shown hereon without permission from THE TECHNICAL MATERIEL CORPORATION to the user. This drawing is loaned for mutual assistance and is subject to recall at any time.

Property of:  
 THE TECHNICAL MATERIEL CORPORATION  
 MAMARONECK, NEW YORK

CK-242

ISSUE	ITEM	CHANGED FROM	DATE	CN. NO.	DRAFTS	CHECKER	ENG. APP.
TOLERANCES				SCALE:			
ALL OTHERS	DEC. DIM. ±	FRAC. DIM. ±	ANGULAR DIM. ±	DRILL PUNCH, COMMERCIAL STOCK SIZES AND MANUFACTURERS TOLERANCES ARE NOT INCLUDED.			

AMD-2			4-1-54
MODEL	PROJECT NO.	ASS'Y. NO.	DATE
USED ON			

REQ. ITEM	PART NO.	DESCRIPTION	SYMBOL
THE TECHNICAL MATERIEL CORP. MAMARONECK, NEW YORK			
SCHEMATIC DIAGRAM AMD-2			
TYPE & TEMPER	JAL	G.T.O	
DRAWN	C.D.W.	ELEC. DES. APP.	MECH. DES. APP.
HEAT TREAT. SPEC.	CHECKED	FINAL APPROVAL	
FINISH & SPEC. NO.	CK-242		