

IF IT IS FOUND DESIRABLE TO CHANGE ANY TOLERANCE OR OTHER DETAIL SPECIFIED ON THIS DRAWING NOTIFY THE PURCHASER PROMPTLY.

MAXIMUM ALLOWABLE TOLERANCES HAVE BEEN DETERMINED AND DEVIATIONS WILL BE CAUSE FOR REJECTION. REMOVE ALL BURRS AND SHARP EDGES

NOTICE TO PERSONS RECEIVING THIS DRAWING

THE TECHNICAL MATERIEL CORPORATION claims proprietary right in the material disclosed hereon. This drawing is issued in confidence for engineering information only and may not be reproduced or used to manufacture anything shown hereon without permission from THE TECHNICAL MATERIEL CORPORATION to the user. This drawing is loaned for mutual assistance and is subject to recall at any time.

Property of:
THE TECHNICAL MATERIEL CORPORATION
MAMARONECK, NEW YORK

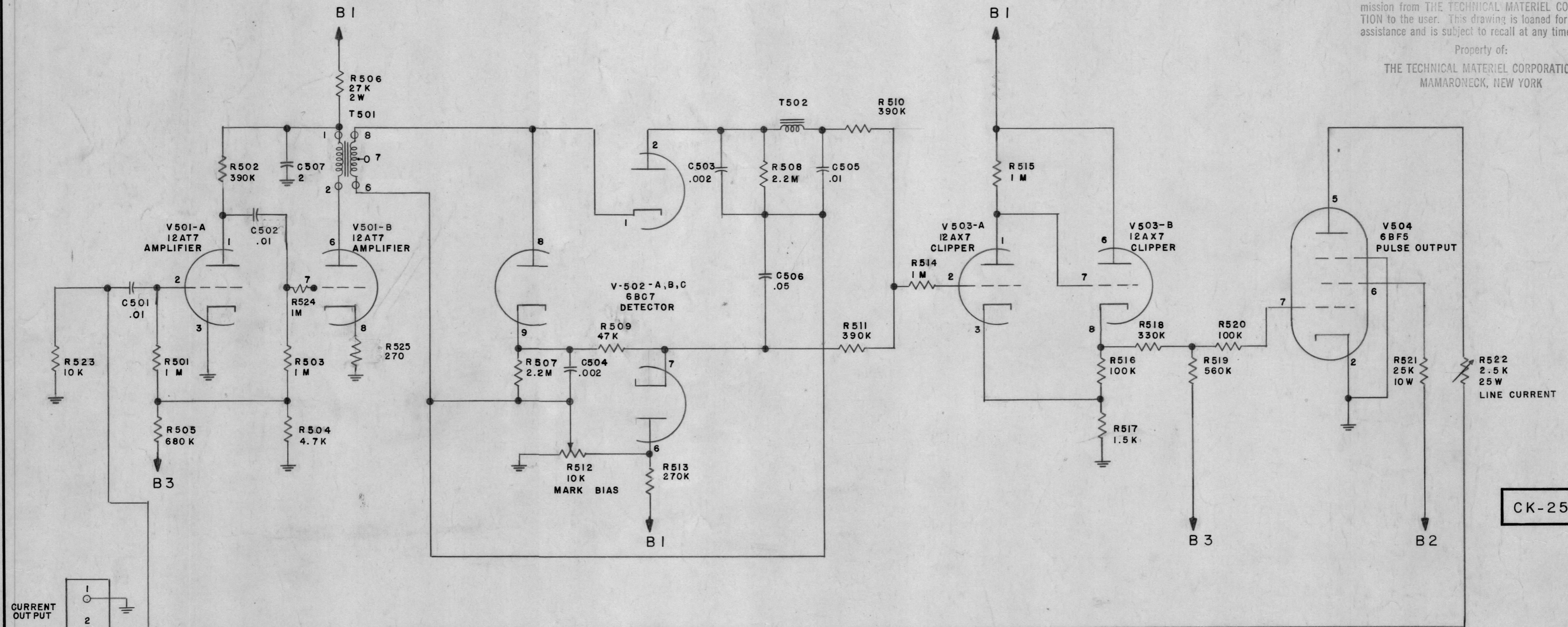

CK-257 E

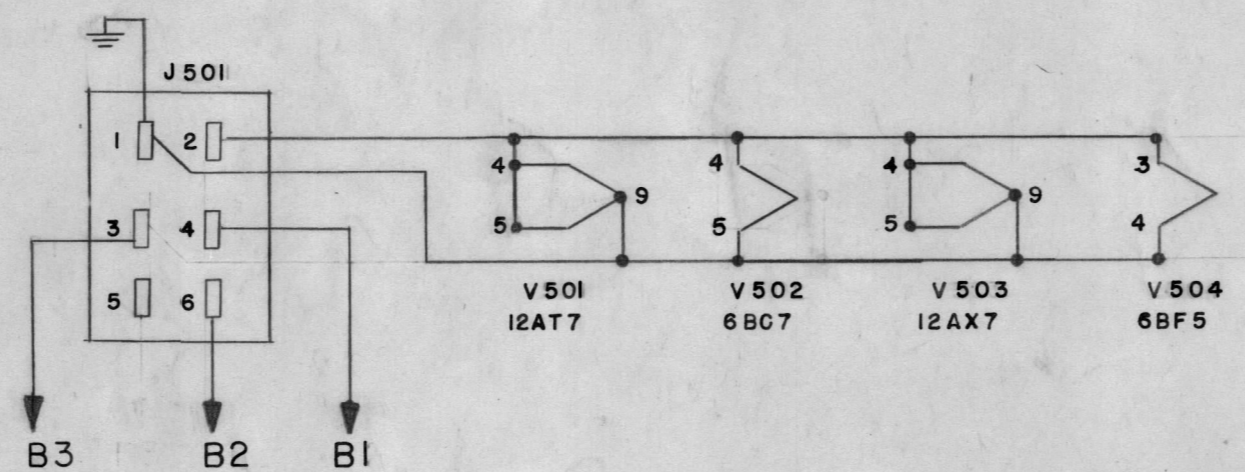
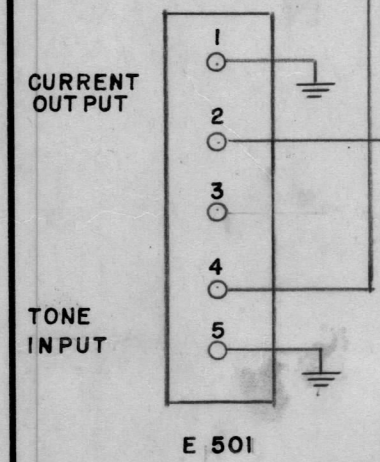

ISSUE	ITEM	CHANGED FROM	DATE	CN. NO.	DRAFTS	CHECKER	ENG. APP.
E	1	R513 WAS 680K R-520, 270 ADDED R-524, 1M ADDED	1/23/59	5	J.C.B.		
D	2	V502 FIL. 4.4E WAS 2.84	4-4-57	4	SC. [Signature]	A.J.J.	
C	1	PIN NUMBERS REVERSED					
B	1	Symbol Series Was Single Digit	3/28/57	3	SC. [Signature]	A.J.J.	
A	1	J501 REWIRED	2/6/57	2	SC. [Signature]	A.J.J.	
A	1	C9 WAS 1.5	5/11/54	1	JAW	COS	ATT

TOLERANCES		SCALE:	
ALL OTHERS	DEC. DIM. ± FRAC. DIM. ± ANGULAR DIM. ±	DRILL, PUNCH, COMMERCIAL STOCK SIZES AND MANUFACTURERS TOLERANCES ARE NOT INCLUDED.	

MODEL	PROJECT NO.	ASS'Y. NO.	DATE
TRU	250		9-13-54

REQ. ITEM	PART NO.	DESCRIPTION	SYMBOL
THE TECHNICAL MATERIEL CORP. MAMARONECK, NEW YORK			
STOCK SIZE			
SCHEMATIC DIAGRAM			
MATERIAL WEIGHT PER PC.			
MODEL TRU			
TYPE & TEMPER			
HEAT TREAT. SPEC.			
FINISH & SPEC. NO.			