

REVISIONS						
ZONE	LTR	DESCRIPTION	DATE	E.M.N.NO	DRAFT	CHKD APPD
	X	EXPERIMENTAL RELEASE	2/3/69		W	
	XI	REVISED & UPDATED	3/7/69		W	JA
	Ø	ORIGINAL RELEASE FOR PRODUCTION	3/12/69		W	JA [Signature]
	A	R1 ADDED	4/7/69		JAT	[Signature]

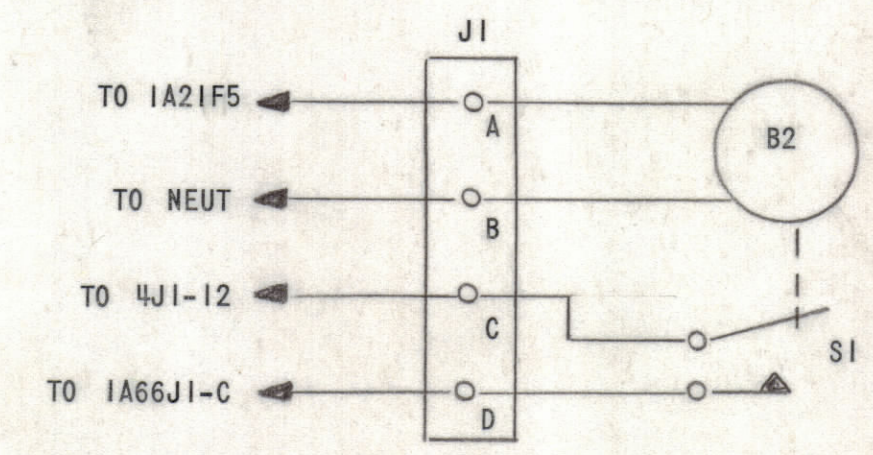
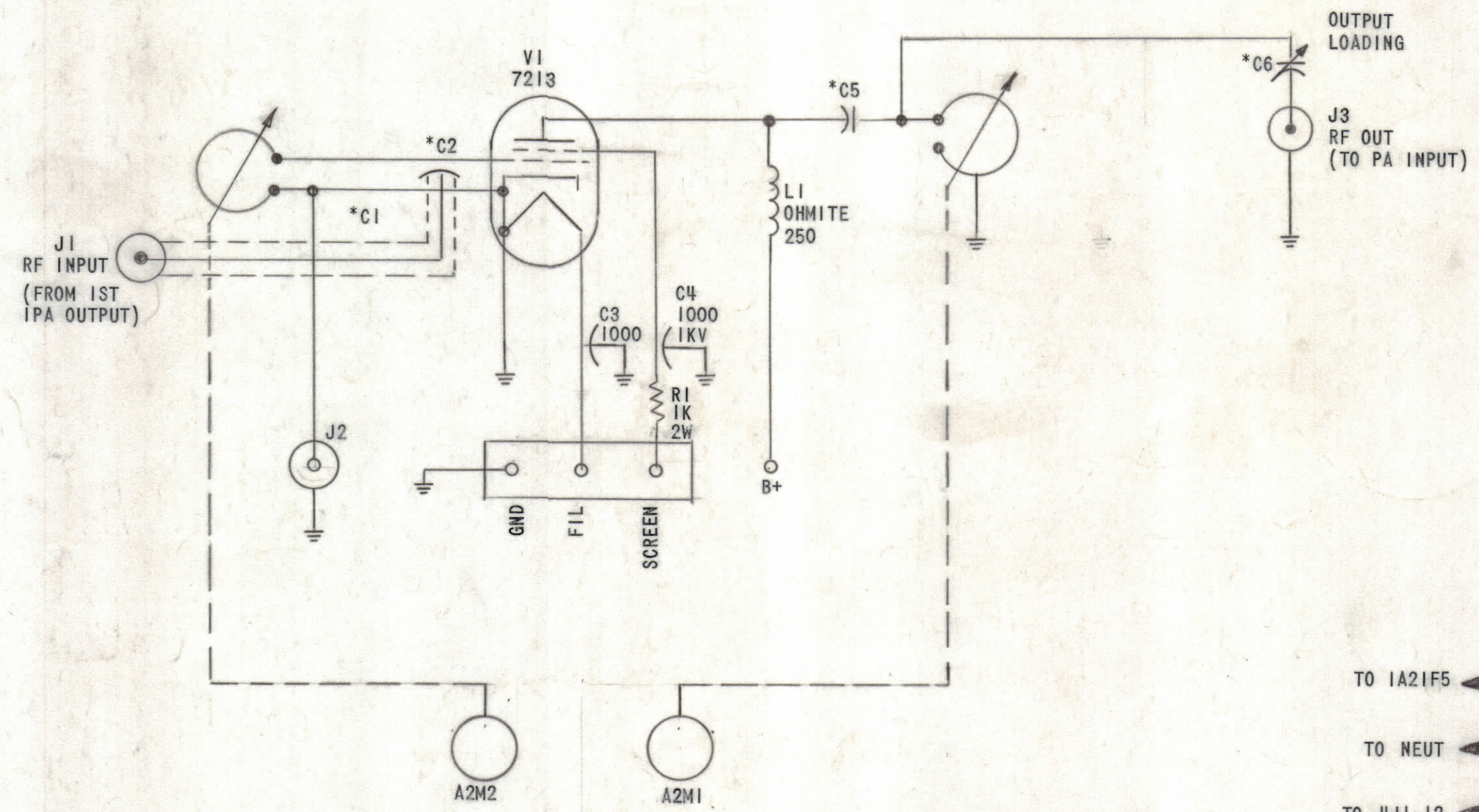

- NOTES:
- * C1, C2, C5 P/O CAVITY ASSEMBLY, NOT SERVICEABLE IN THE FIELD.
 - ALL REF SYMBOLS PREFIXED BY:
- | CHAN | PREFIX |
|------|--------|
| 2 | IA46 |
| 3 | IA35 |

QTY / UNIT	SPT-3KVHF	AX8080
	MODEL USED ON	ASS'Y NO.
APPLICATION		
	CODE	

NOTICE TO PERSONS RECEIVING THIS DRAWING
 THE TECHNICAL MATERIEL CORPORATION claims proprietary right in the material disclosed hereon. This drawing is issued in confidence for engineering information only and may not be reproduced or used to manufacture anything shown hereon without permission from THE TECHNICAL MATERIEL CORPORATION to the user. This drawing is loaned for mutual assistance and is subject to recall at any time.

UNLESS OTHERWISE SPECIFIED DIMENSIONS ARE IN INCHES AND INCLUDE CHEMICALLY APPLIED OR PLATED FINISHES

TOLERANCES ON
 DECIMALS .X ± .05
 .XX ± .01
 .XXX ± .005
 FRACTIONS ± 1/64
 ANGLES ± 0° -30'

MATERIAL
 FINISH

QTY. REQ.	ITEM	PART NO.	DESCRIPTION	SYMBOL
LIST OF MATERIAL				
FINAL APPROVAL		DATE	THE TECHNICAL MATERIEL CORP.	
MECH. DES.		DATE	MAMARONECK, NEW YORK	
ELECT. DES.		DATE	LOW BAND 2ND I.P.A.	
CHECKED		DATE		
DRAWN		DATE		
SIZE	CODE	IDENT. NO.	DWG NO.	ISSUE
C		82679	CK 8163	A
SCALE		SHEET		OF