

REVISIONS						
ZONE	LTR	DESCRIPTION	DATE	E.M.N. NO.	DRAFT	CHKD
	0	ORIGINAL RELEASE FOR PRODUCTION	5/26/69	#	GE	

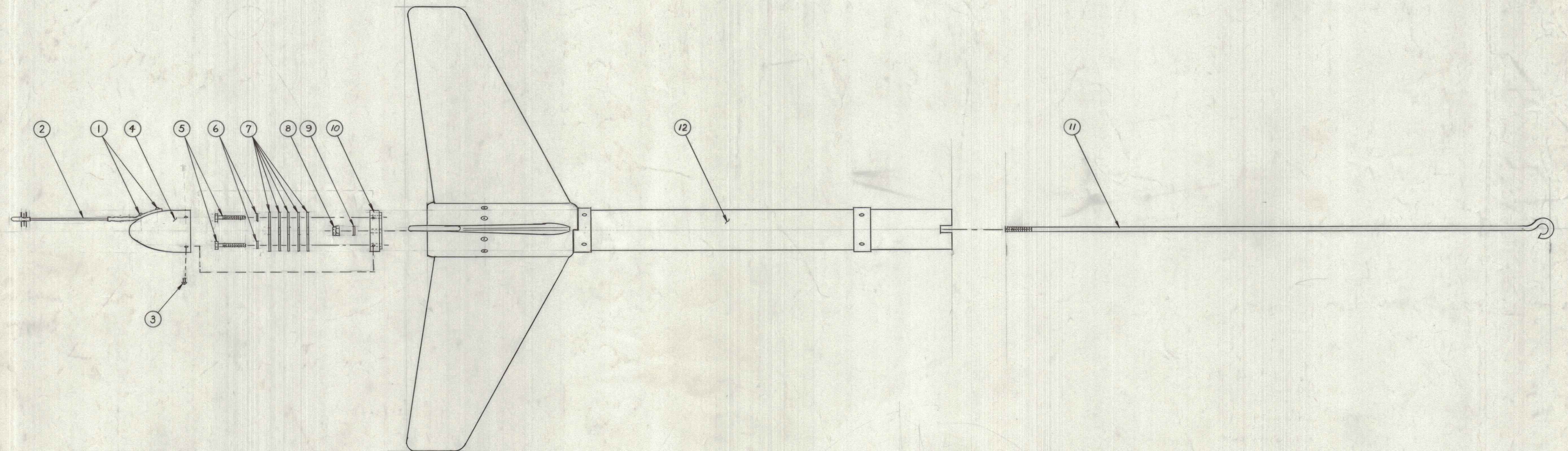

QTY. REQ.	ITEM	PART NO.	DESCRIPTION	SYMBOL
1	12	AX8084	TAIL FIN SUB-ASSEMBLY	
1	11	MS8303	RETAINING BAR	
1	10	MS8310	MOUNTING BRACKET	
1	9	AN7600616	WASHER, FLAT (ALBANY-TYPE 302)	
1	8	MS210460-6	NUT, CASTELLATED HEXAGON (FLEXLOC)	
AR	7	MS8311	WASHER, LEAD	
2	6	AN7600416	WASHER, FLAT (ALBANY)	
2	5	MS8297	BOLT, HEXAGON HEAD	
1	4	MS8309	TAIL CONE	
4	3	MS8298	NYLON MACH. SCREW, ROUND HEAD	
1	2	MS8302	NULL FIELD DISCHARGER	
2	1		SCREW	

LIST OF MATERIAL  
**THE TECHNICAL MATERIEL CORP.**  
 MAMARONECK, NEW YORK

*TAIL FIN ASSEMBLY ON DETAILS*

UNLESS OTHERWISE SPECIFIED DIMENSIONS ARE IN INCHES AND INCLUDE CHEMICALLY APPLIED OR PLATED FINISHES	FINAL APPROVAL <i>JAM</i>	DATE 5/19/69
TOLERANCES ON	MECH. DES.	DATE
DECIMALS .X ± .05 .XX ± .01 .XXX ± .005	ELECT. DES.	DATE
FRACTIONS ± 1/64 ANGLES ± 0°-30'	CHECKED <i>JAM</i>	DATE 5-9-69
	DRAWN <i>TANTILLO</i>	DATE 7-11-68

1	ATW-1	AX8083
QTY / UNIT	MODEL USED ON	ASSY'Y NO.
	APPLICATION	
	CODE	
NOTICE TO PERSONS RECEIVING THIS DRAWING		
THE TECHNICAL MATERIEL CORPORATION claims proprietary right in the material disclosed hereon. This drawing is issued in confidence for engineering information only and may not be reproduced or used to manufacture anything shown hereon without permission from THE TECHNICAL MATERIEL CORPORATION to the user. This drawing is loaned for mutual assistance and is subject to recall at any time.		
MATERIAL	SEE LIST	
FINISH		

SIZE	CODE IDENT. NO.	DWG NO.	ISSUE
D	82679	128054	0
SCALE	1/4" = 1"	SHEET	OF