

IT IS FOUND DESIRABLE TO CHANGE ANY TOLERANCE OR OTHER DETAIL SPECIFIED ON THIS DRAWING NOTIFY THE PURCHASER PROMPTLY.
 MAXIMUM ALLOWABLE TOLERANCES HAVE BEEN DETERMINED AND DEVIATIONS WILL BE CAUSE FOR REJECTION. REMOVE ALL BURRS AND SHARP EDGES

- A - #9 (.196) DRILL - 5 HOLES
- B - 1/4-20 TAP - 11 REQ'D
- C - DRILL & C-BORE 5/8 D x 1/16 Dp. FROM REAR - 3 REQ'D
- D - 5/8 (.625) D - 4 HOLES

OVEN JIG PLATE MODEL VOX & PMO

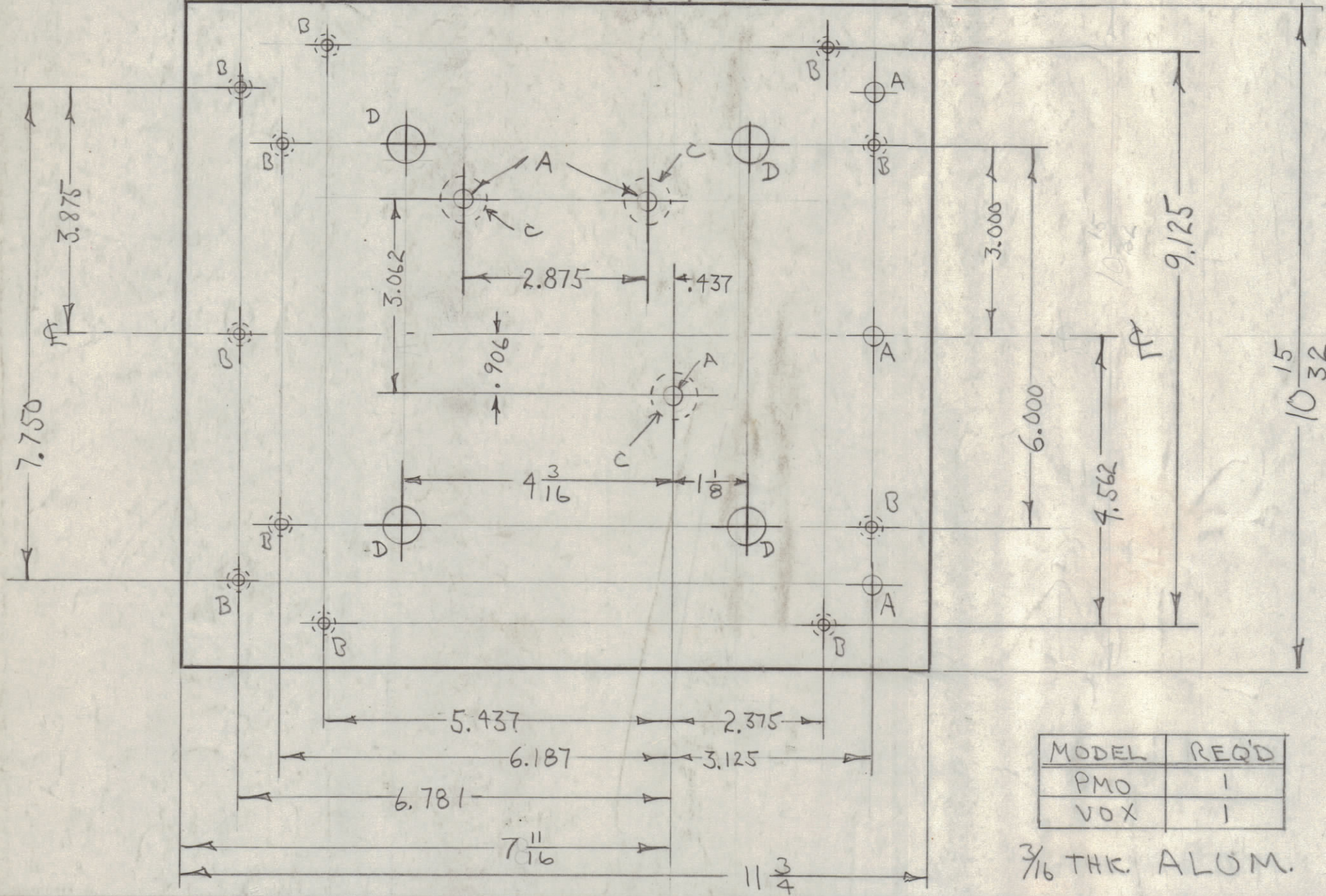

MODEL	REQ'D
PMO	1
VOX	1

3/16 THK. ALUM.

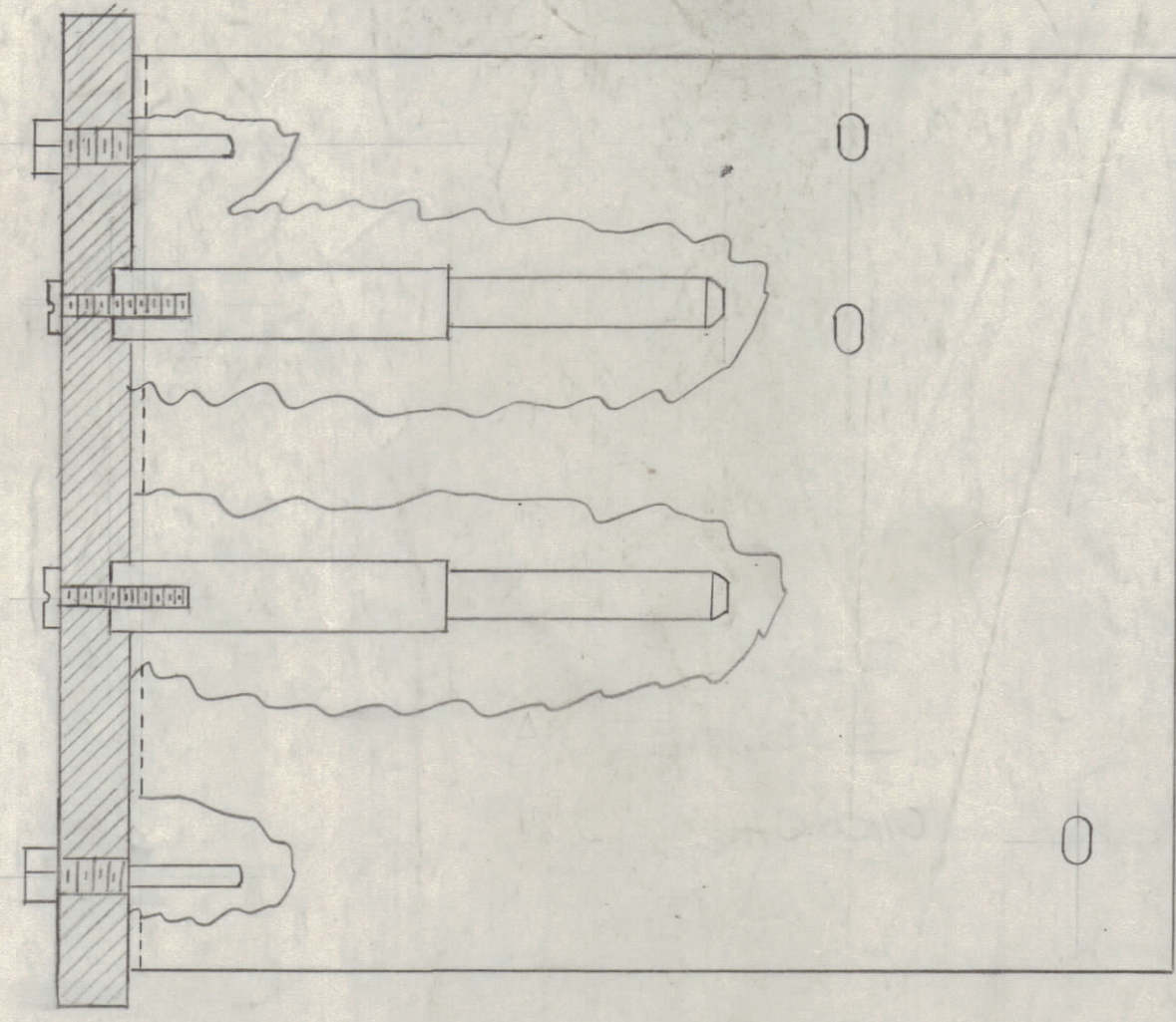

ASSEMBLE AS SHOWN

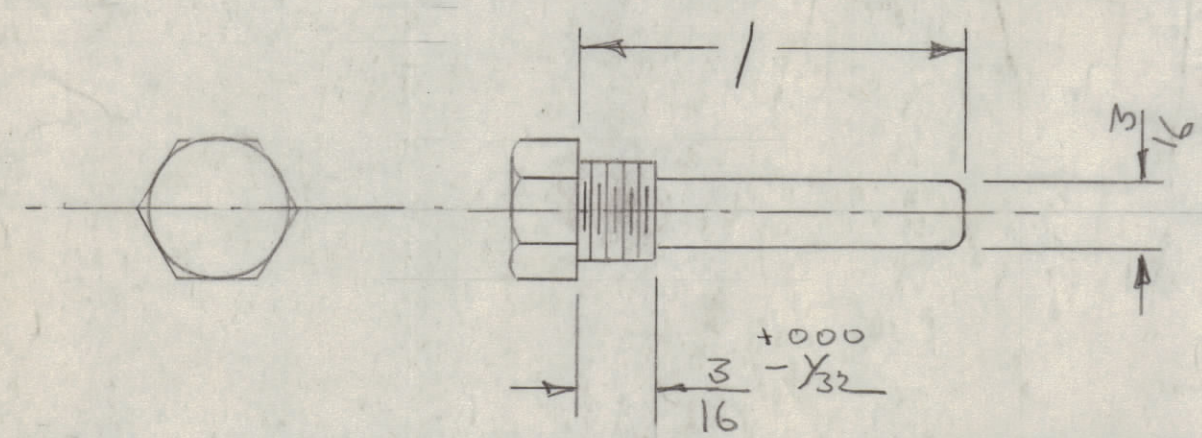

MODIFY SCHH 2520 SC16 AS SHOWN

REQ'D	MODEL
3	PMO
8	VOX

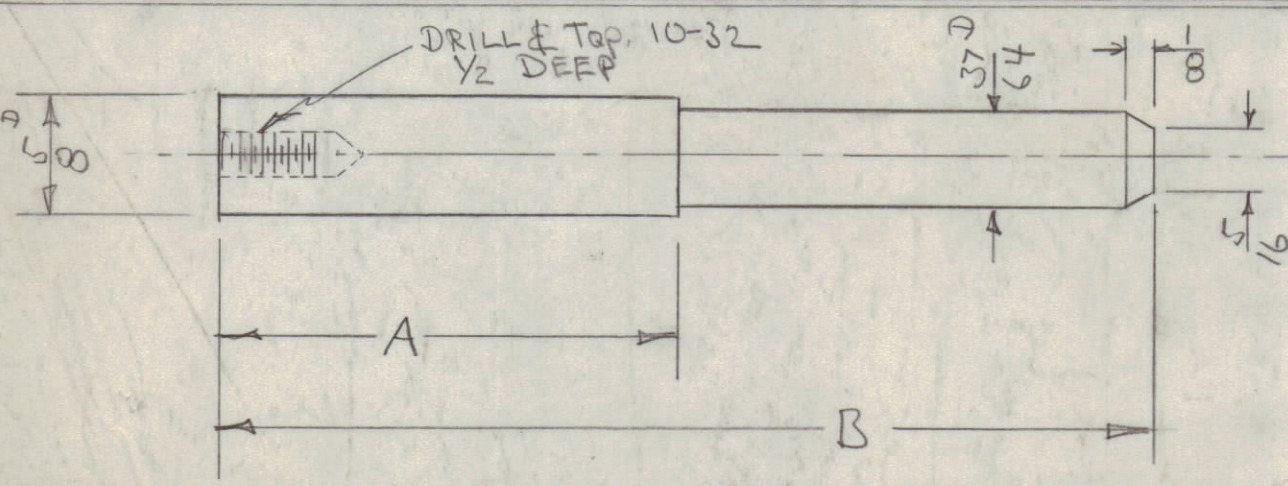

MODEL	A	B	REQ'D PER UNIT
PMO	2 3/8	4 3/4	3
VOX	6 3/8	8 3/4	3

5/8 BRASS ROD

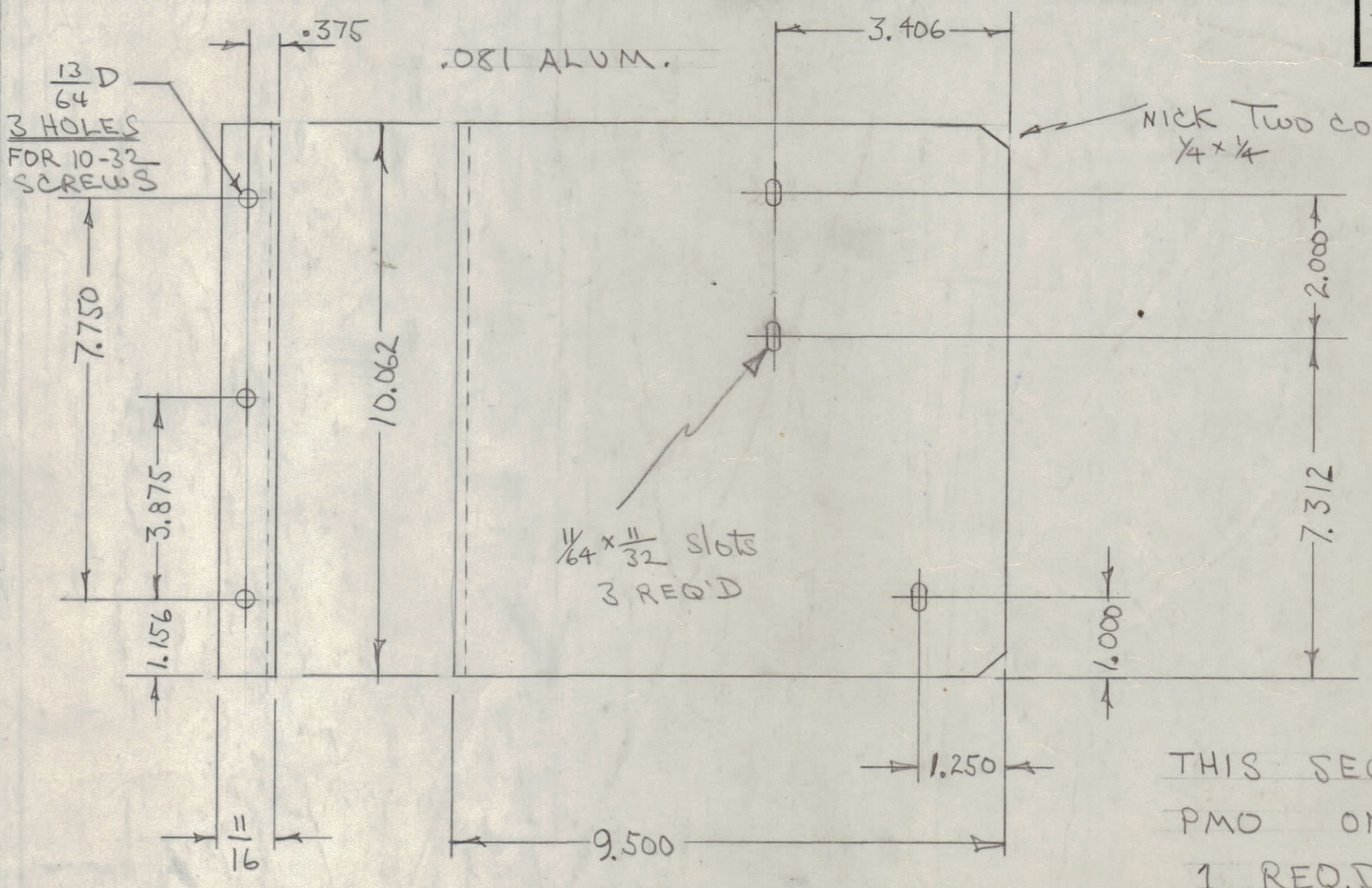

JG-100

THIS SECTION FOR PMO ONLY 1 REQ'D

ISSUE	ITEM	CHANGED FROM	DATE	CN. NO.	DRAFTS	CHECKER	ENG. APP.
TOLERANCES							
ALL OTHERS			SCALE:				
DEC. DIM. ±			DRILL, PUNCH, COMMERCIAL STOCK				
FRAC. DIM. ±			SIZES AND MANUFACTURERS				
ANGULAR DIM. ±			TOLERANCES ARE NOT INCLUDED.				

SEE	PMO	285	8-22-54
NOTES	VOX		8-22-54
REQ'D	MODEL	PROJECT NO.	ASS'Y. NO.
			DATE

REQ. ITEM	PART NO.	DESCRIPTION	SYMBOL
THE TECHNICAL MATERIEL CORP.			
MAMARONECK, NEW YORK			
OVEN JIG			
PMO - VOX			
DRAWN		ELEC. DES. APP.	MECH. DES. APP.
CHECKED		FINAL APPROVAL	
		JG-100	