

REVISIONS							
ZONE	SYM	DESCRIPTION	DATE	E.M.N. NO.	DRAFT	CHKD	APPD
	0	ORIGINAL RELEASE FOR PRODUCTION	3-2-64		A.M.		

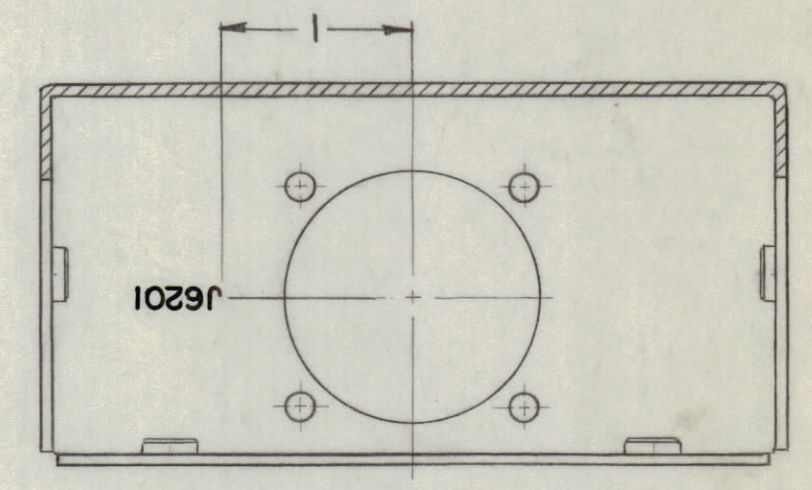

SECTION-B-B

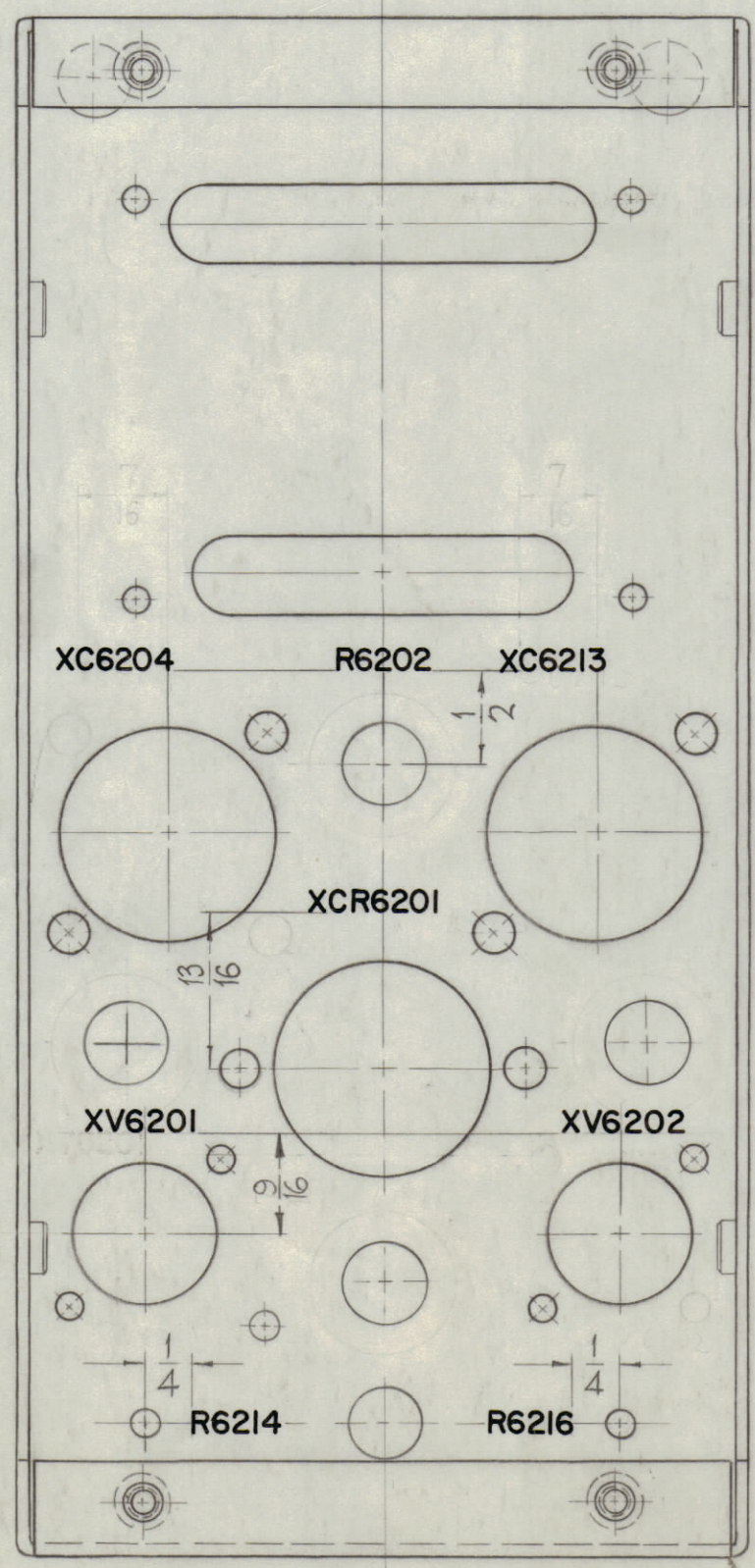
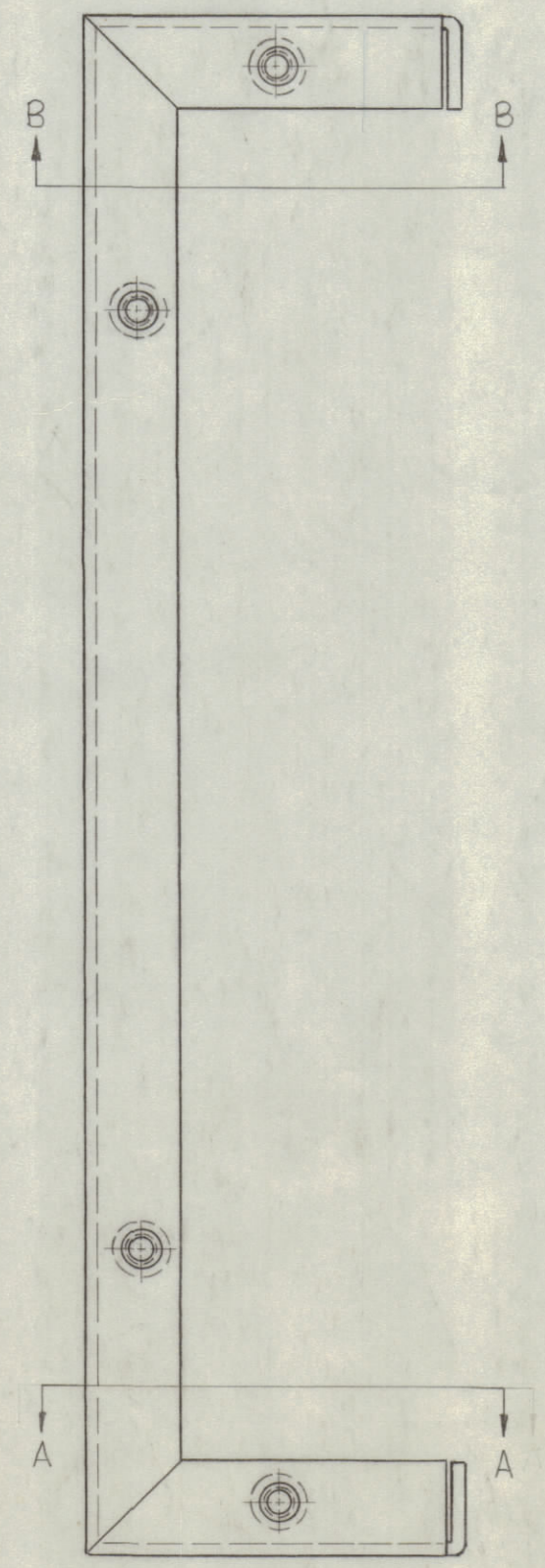
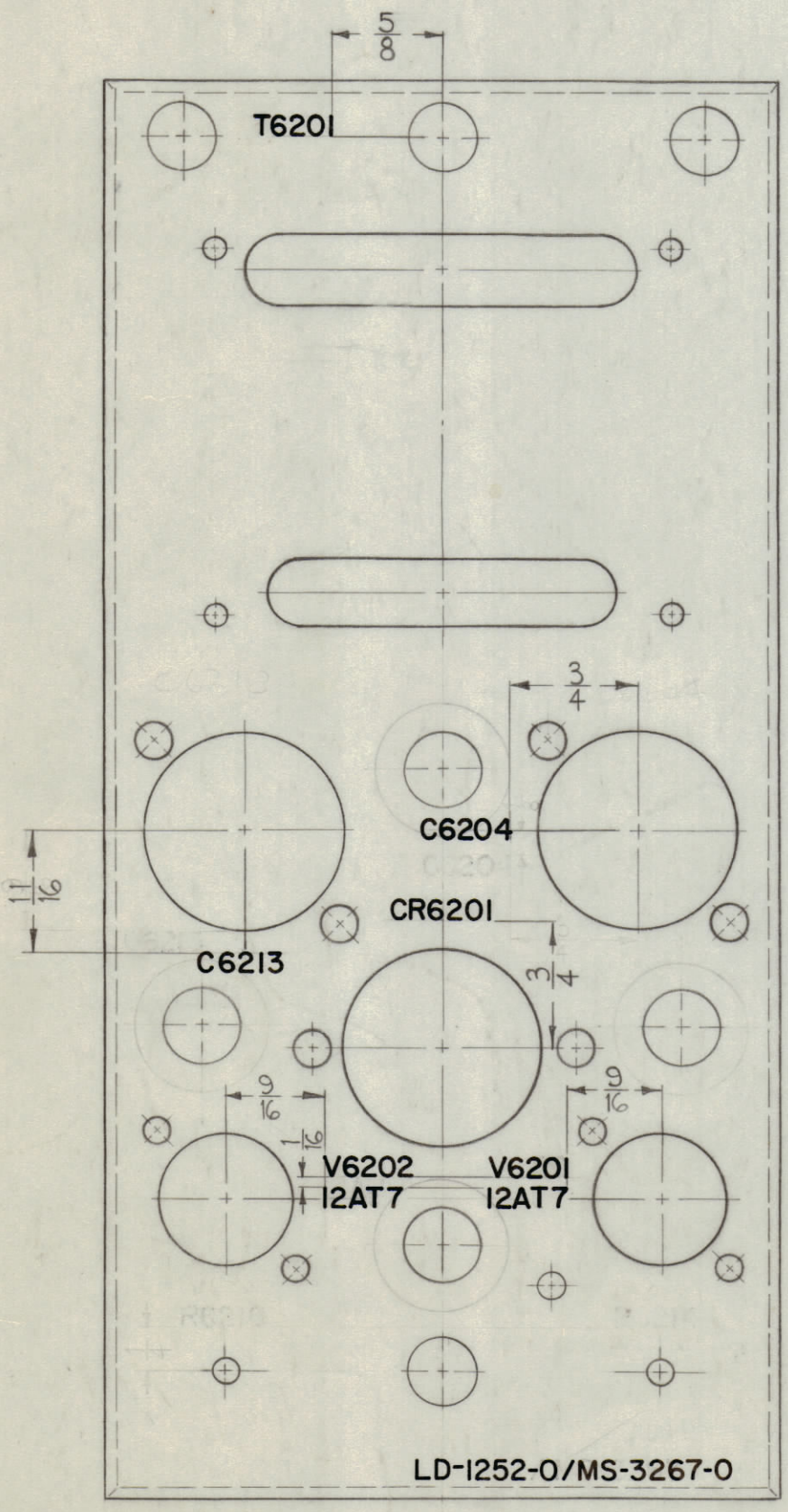
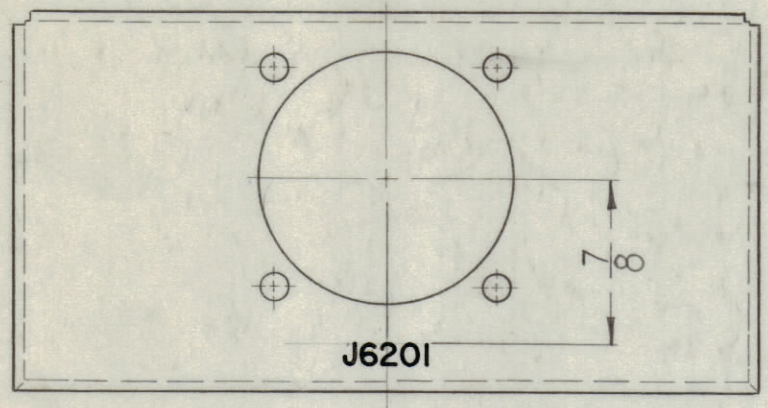
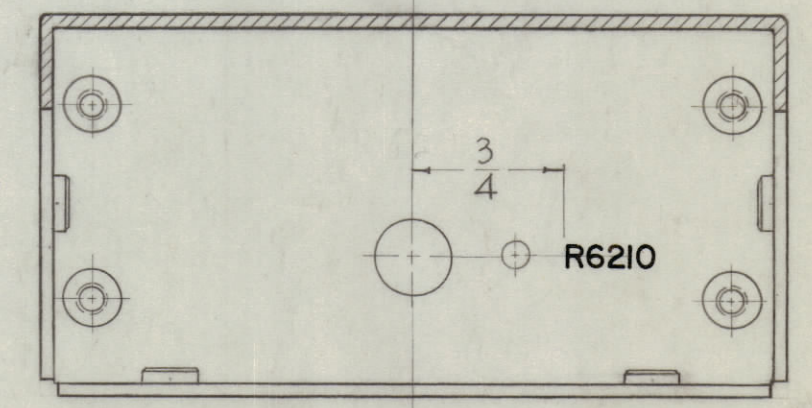

SECTION-A-A

MARKING PROCESS: AS PER TMC SPEC S727.
 LETTERING: 1/8 HIGH BLACK GOTHIC LOCATED AS SHOWN UNLESS OTHERWISE SPECIFIED.

1	GPT-200K	AZ-101
Q'TY./UNIT	MODEL USED ON	ASS'Y. NO.
SCALE 1:1	CODE A	

THE CONTENTS OF THIS DRAWING ARE THE EXCLUSIVE PROPERTY OF THE TECHNICAL MATERIEL CORP. ITS UNAUTHORIZED USE OR REPRODUCTION IN WHOLE OR IN PART IS STRICTLY FORBIDDEN.

NOTES

REQ'D.	ITEM	PART NUMBER	DESCRIPTION	SYMBOL
F. BUDETTI LIST OF MATERIAL				
MATERIAL		THE TECHNICAL MATERIEL CORP. MAMARONECK, NEW YORK		
FINISH		TITLE MARKING, MAIN CHASSIS MARKING PROCESS: PER SPEC S-727		
UNLESS OTHERWISE SPECIFIED DIMENSIONS ARE IN INCHES AND INCLUDE CHEMICALLY APPLIED OR PLATED FINISHES		DRAWN SRG	DATE 3-7-63	FINAL APPROVAL RAC
DECIMALS .X ± .05 .XX ± .01 .XXX ± .005		CHECKED JCB	DATE 2/11/64	
FRACTIONS ± 1/64 ANGLES ± 0° 30'		ELECT. DES. S.D.	DATE 2-11-64	
TOLERANCES		MECH. DES.	DATE	
			SHEET	REV. LTR.

LD-1252 0