

REVISIONS							
ZONE	SYM	DESCRIPTION	DATE	E.M.N. NO.	DRAFT	CHKD	APPD
XI		J910 & J911 WERE P901 & P902	6/16/64	XI	A.M.		
		ORIGINAL RELEASE FOR PRODUCTION	6/29/64		A.M.		
AB,9	A	3 HOLES 1/64 DIA. ADD.	9/30/64	12489	JTB		
C8	B	2 HOLES 1/8 DIA. ADD.	10/30/64	12794	JTB		
D7	C	2 HOLES 9/64 ADD; R954 & LOC. DIM. ADD.	12/17/64	13178	JTB		
CB,9	D	3 HOLES 5/32 DIA. ADDED.	1/18/65	13267	JTB		

~ BOTTOM VIEW ~

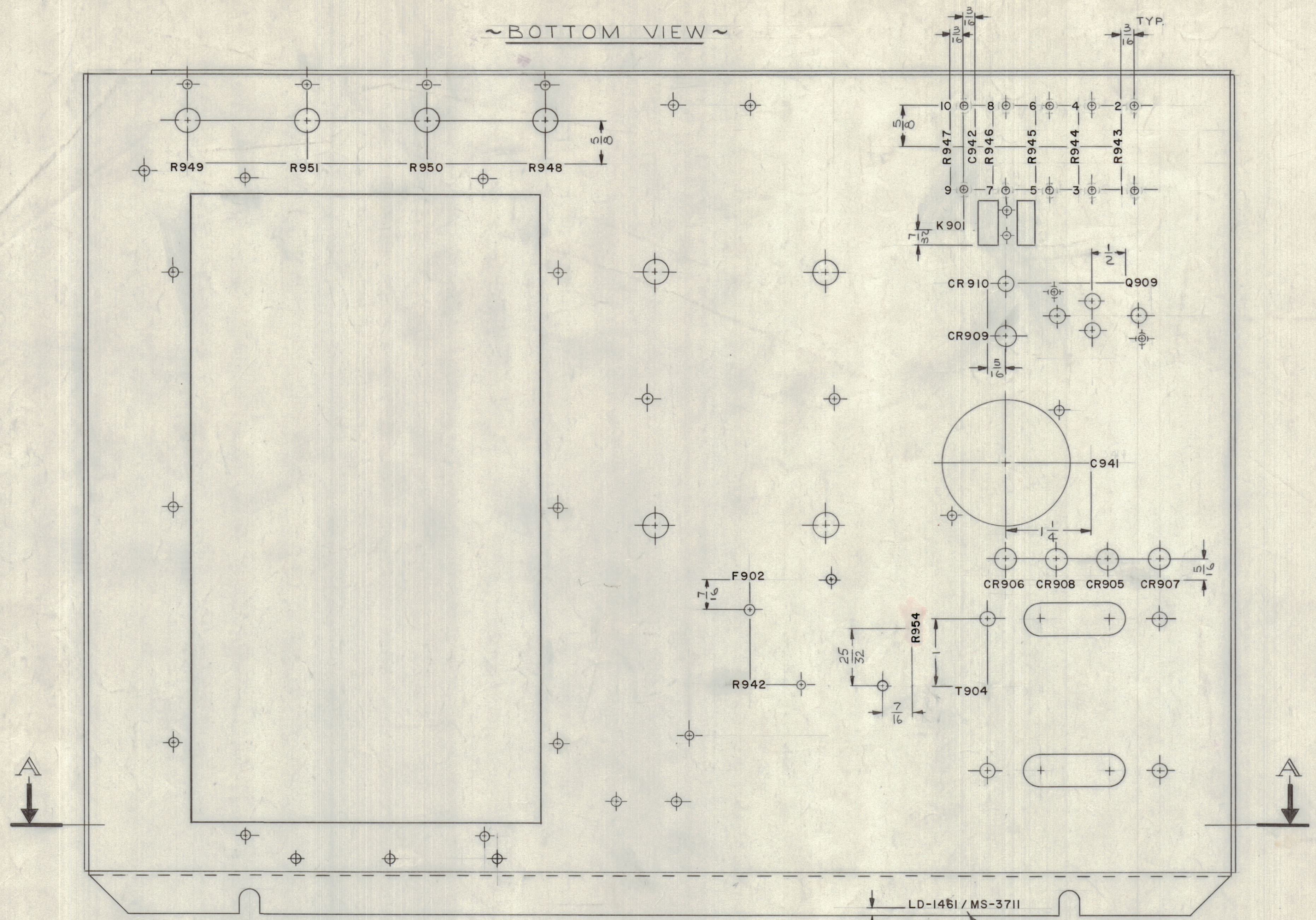

MARK TMC PART NO. WITH LATEST REVISION LETTERS

~ UNLESS OTHERWISE SPECIFIED ~

- 1- MARKING PROCESS: AS PER TMC SPECIFICATION S-727.
- 2- LETTERING: 1/8 HIGH BLACK GOTHIC, LOCATED AS SHOWN.

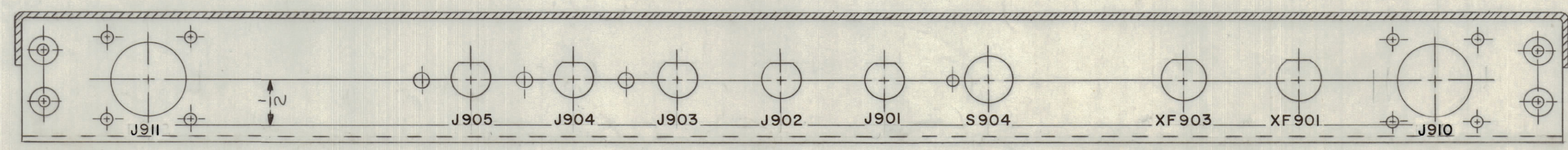

VIEW A-A

REF. MS 3711

REQ'D.	ITEM	PART NUMBER	DESCRIPTION	SYMBOL
M. GELMAN			LIST OF MATERIAL	
MATERIAL		THE TECHNICAL MATERIEL CORP. MAMARONECK, NEW YORK		
FINISH		TITLE MARKING, CHASSIS, ELECT.-MAIN MARKING METHOD TMC S727		
1	CSS-2			
QTY./UNIT	MODEL USED ON	ASSY. NO.	DRAWN	DATE
SCALE 1:1	CODE A		J. LESHINSKI	4/15/64
THE CONTENTS OF THIS DRAWING ARE THE EXCLUSIVE PROPERTY OF THE TECHNICAL MATERIEL CORP. ITS UNAUTHORIZED USE OR REPRODUCTION IN WHOLE OR IN PART IS STRICTLY FORBIDDEN.		DECIMALS ± .05	FRACTIONS ± 1/64	ANGLES ± 0° 30'
		TOLERANCES ± .01	ELECT. DES.	DATE
		± .005	MECH. DES.	DATE
				FINAL APPROVAL
				DATE
				REV. LTR.
				LD 1461 D
				SHEET 2 OF 2

NOTES

LD-1461 D