

THE CONTENTS OF THIS DRAWING ARE THE EXCLUSIVE PROPERTY OF THE TECHNICAL MATERIEL CORP. ITS UNAUTHORIZED USE OR REPRODUCTION IN WHOLE OR IN PART IS STRICTLY FORBIDDEN.

LD-1402

LD-1402/MS-3581

STAMP TMC PART NO. 1/8 HIGH GOTHIC. (BLACK)

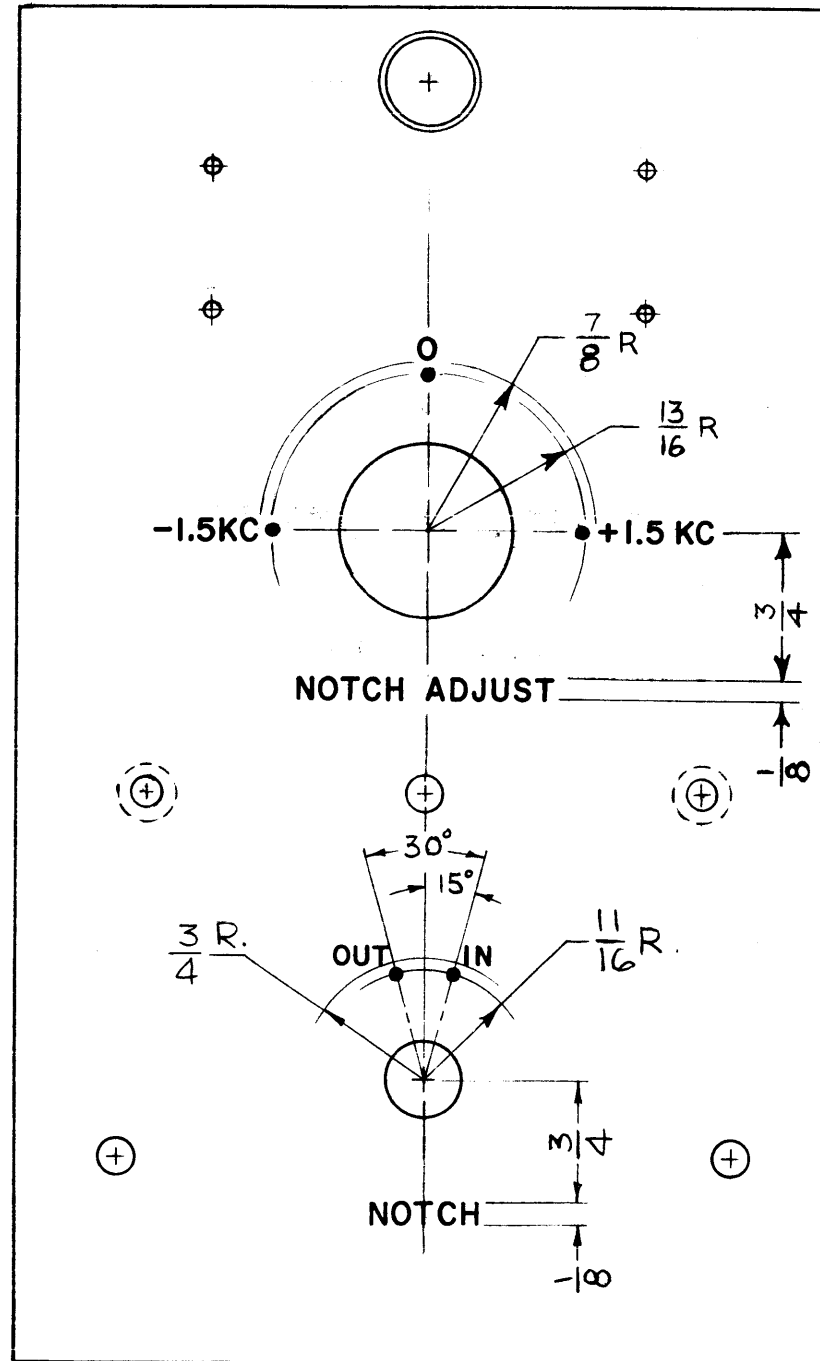

FRONT VIEW

- UNLESS OTHERWISE SPECIFIED:
1. ALL ENGRAVING TO BE 3/32 HIGH, WHITE FILLED GOTHIC.
 2. ALL DOTS TO BE WHITE FILLED.
 3. ALL LETTER GROUPS TO BE CENTERED ON HOLES.

HEIGHT OF LETTERS	DEPTH OF STROKE	WIDTH OF STROKE
3/32	.010	.015
1/8	.010	.020
DOTS	.010	1/16 DIA

REF: MS-3581

REQ.	ITEM	PART NO.	AALTONEN DESCRIPTION	SYMBOL
			THE TECHNICAL MATERIEL CORP. MAMARONECK, NEW YORK	
			MARKING, FRONT PANEL	
			MARKING METHOD. ENGRAVING	
			T. RAMIREZ 1-9-64	2/21/64
			DRAWN	CHECKED
			FINAL APPROVAL	
			ELEC. DES. APP.	MECH. DES. APP.
			LD-1402	

SYM	DESCRIPTION	DATE	CH. NO.	DRAFTS	CHECKER	ENG. APP.
	UNLESS OTHERWISE SPECIFIED:					
	DIMENSIONS ARE IN INCHES	SCALE: 1:1			CODE A	
	TOLERANCES ON FRACTIONS ± 1/64					
	DECIMALS ± .005					
	ANGLES ± 1/2°					
	REMOVE ALL BURRS AND SHARP EDGES					

REQ. PER UNIT	MODEL	SECTION	ASS'Y. NO.	DATE
4	MNF-1			7-10-63

USED ON

LD-1406

REVISIONS						
SYM	DESCRIPTION	DATE	E.M.N. NO.	DRAFT	CHK	APPD
X1	WORD "OVENS" WAS 3/32 HIGH	1-21-64	X1	N.P.		
0	ORIGINAL RELEASE FOR PRODUCTION	4/13/64	0	A.M.	@	

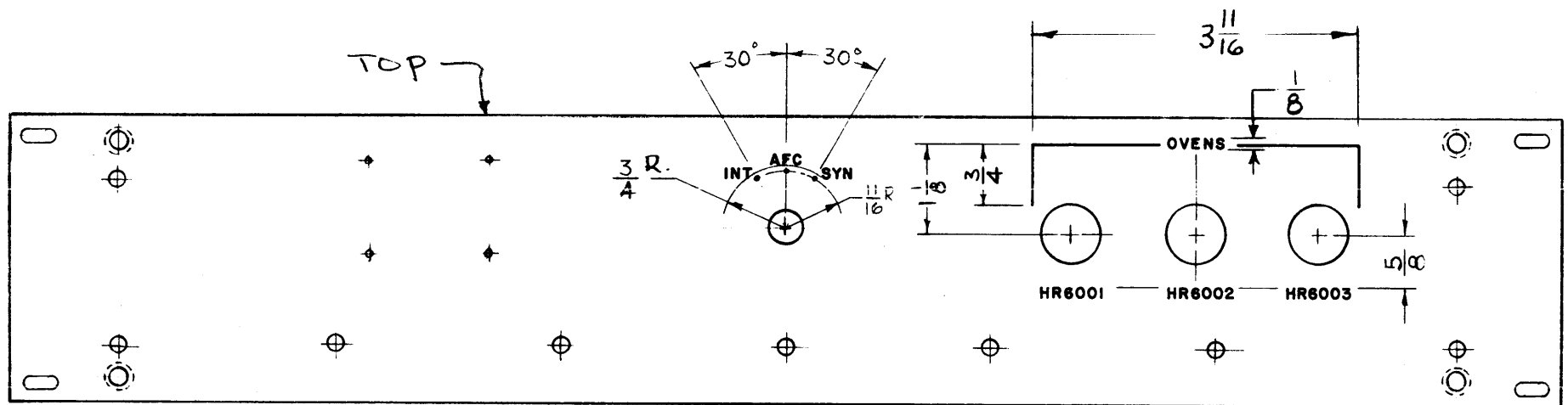

FRONT OF PANEL SHOWN

UNLESS OTHERWISE SPECIFIED

NOTE:

1. ALL ENGRAVING TO BE 3/32 HIGH WHITE FILLED GOTHIC LETTERS.
2. ALL DOTS TO BE WHITE FILLED.
3. ALL LETTER GROUPS TO BE CENTERED ON HOLES.

HEIGHT OF LETTERS	DEPTH OF STROKE	WIDTH OF STROKE
3/32	.010	.015
DOTS	.010	1/16 DIA.
LINE	.010	.015
1/8	.010	.020

REF: MS-3594

REQ'D.	ITEM	PART NUMBER	DESCRIPTION	SYMBOL
AALTONEN LIST OF MATERIAL				
MATERIAL			THE TECHNICAL MATERIEL CORP. MAMARONECK, NEW YORK	
FINISH			TITLE MARKING, FRONT PANEL MARKING METHOD: ENGRAVING	
UNLESS OTHERWISE SPECIFIED DIMENSIONS ARE IN INCHES AND INCLUDE CHEMICALLY APPLIED OR PLATED FINISHES			DRAWN T. RAMIREZ DATE 7/12/63	FINAL APPROVAL DATE 4/22/64
DECIMALS .X ± .05 .XX ± .01 .XXX ± .005			CHECKED DATE 1-31-64	DATE 7/13/64
FRACTIONS ± 1/64 ANGLES ± 0° 30'			ELECT. DES. DATE 1-31-64	MECH. DES. DATE 1-31-64
TOLERANCES			LD-1406	
THE CONTENTS OF THIS DRAWING ARE THE EXCLUSIVE PROPERTY OF THE TECHNICAL MATERIEL CORP. ITS UNAUTHORIZED USE OR REPRODUCTION IN WHOLE OR IN PART IS STRICTLY FORBIDDEN.			SHEET 1 OF 2	
NOTES			REV. LTR.	

LD-1406 0

REVISIONS						
SYM	DESCRIPTION	DATE	E.M.N. NO.	DRAFT	CHKD	APPD
X1	CHANGE MADE ON SHEET 1	1-21-64	X1	NP		
0	ORIGINAL RELEASE FOR PRODUCTION	4/13/64	0	A.M.	@	

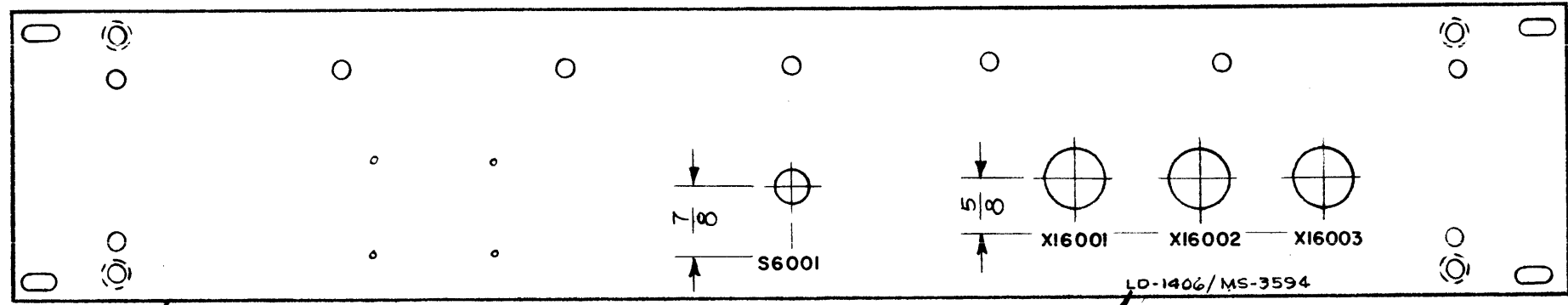

TOP

REAR OF PANEL AS SHOWN

TMC P/N APPROX. AS SHOWN

MARKING PROCESS: AS PER TMC SPECIFICATION S-727.
LETTERING: 1/8 HIGH BLACK GOTHIC, LOCATED AS SHOWN.
ALL LETTER GROUPS TO BE CENTERED ON HOLES.

REF: MS-3594

REQ'D.	ITEM	PART NUMBER	DESCRIPTION	SYMBOL
AALTONEN LIST OF MATERIAL				
MATERIAL		THE TECHNICAL MATERIEL CORP. MAMARONECK, NEW YORK		
FINISH		TITLE MARKING, FRONT PANEL MARKING METHOD, TMC S-727		
UNLESS OTHERWISE SPECIFIED DIMENSIONS ARE IN INCHES AND INCLUDE CHEMICALLY APPLIED OR PLATED FINISHES		DRAWN <i>N. Retta</i>	DATE 12-4-63	FINAL APPROVAL <i>RDR</i>
		CHECKED <i>R. Torga</i>	DATE 1-3-64	DATE 4/22/64
		ELECT. DES. <i>A. K. C.</i>	DATE 1/31/64	LD-1406
		MECH. DES. <i>M. Zetina</i>	DATE 1-31-64	0
			SHEET 2 OF 2	REV. LTR.

1	MCG-1	
Q'TY./UNIT	MODEL USED ON	ASS'Y. NO.
SCALE 1:2	CODE A	
THE CONTENTS OF THIS DRAWING ARE THE EXCLUSIVE PROPERTY OF THE TECHNICAL MATERIEL CORP. ITS UNAUTHORIZED USE OR REPRODUCTION IN WHOLE OR IN PART IS STRICTLY FORBIDDEN.		

NOTES

LD-1420 0

REVISIONS

SYM	DESCRIPTION	DATE	E.M.N. NO.	DRAFT	CHKD	APPD
X2	LETTERING ADDED	2-10-64	—	SRG		
0	ORIGINAL RELEASE FOR PRODUCTION	7-29-64	—	SRG		

MARKING ON REAR LD-1420/MS-3602, WITH LATEST REVISION LETTERS.

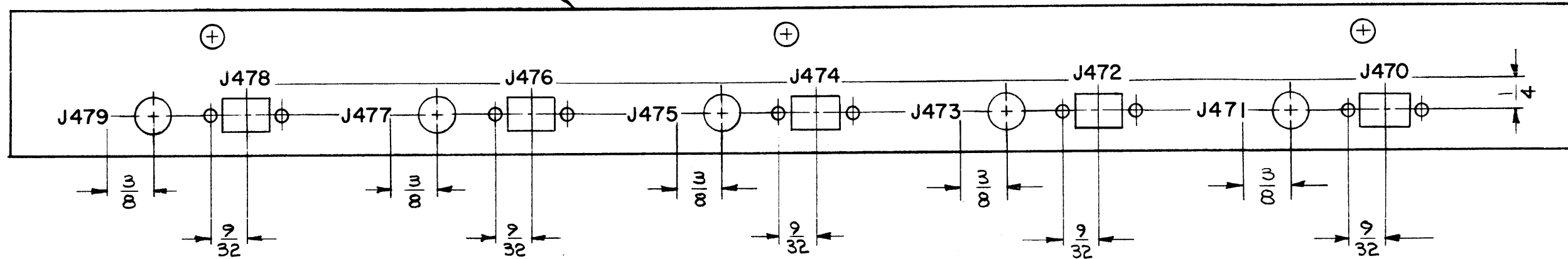

UNLESS OTHERWISE SPECIFIED:

MARKING PROCESS: AS PER TMC SPECIFICATION S-727.

LETTERING: 1/8 HIGH BLACK GOTHIC, LOCATED AS SHOWN.

REF: MS-3602 (2)

REQ'D.	ITEM	PART NUMBER	DESCRIPTION	SYMBOL
GELLMAN LIST OF MATERIAL				
MATERIAL		THE TECHNICAL MATERIEL CORP. MAMARONECK, NEW YORK		
FINISH		TITLE MARKING, BRACKET, MOUNTING, CONNECTOR - MAIN CHASSIS MARKING PROCESS - PER TMC SPEC. S-727		
UNLESS OTHERWISE SPECIFIED DIMENSIONS ARE IN INCHES AND INCLUDE CHEMICALLY APPLIED OR PLATED FINISHES		DRAWN <i>G. Jansen</i> DATE 2-10-64	FINAL APPROVAL <i>[Signature]</i> DATE 7-28-64	DATE
DECIMALS .X ± .05 .XX ± .01 .XXX ± .05		ELECT. DES. <i>[Signature]</i> DATE 7-28-64		LD-1420 0
FRACTIONS ± 1/64 ANGLES ± 0° 30'		MECH. DES. <i>[Signature]</i> DATE 7-28-64		
TOLERANCES		SHEET		REV. LTR.

I	LFS-I	
Q'TY./UNIT	MODEL USED ON	ASS'Y. NO.
SCALE 1:1	CODE A	
THE CONTENTS OF THIS DRAWING ARE THE EXCLUSIVE PROPERTY OF THE TECHNICAL MATERIEL CORP. ITS UNAUTHORIZED USE OR REPRODUCTION IN WHOLE OR IN PART IS STRICTLY FORBIDDEN.		

NOTES

LD-1427 0

REVISIONS

SYM	DESCRIPTION	DATE	E.M.N. NO.	DRAFT	CHKD	APPD
0	ORIGINAL RELEASE FOR PRODUCTION	4-24-64	0	A.M.	@	

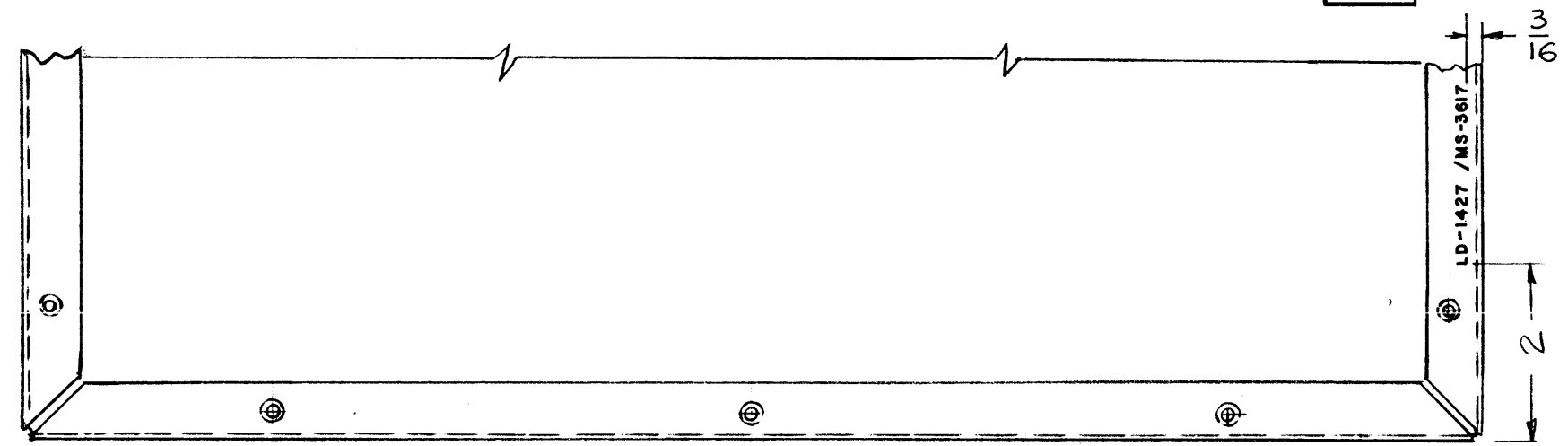

MARKING PROCESS: AS PER TMC SPECIFICATION S-727.
 LETTERING: 1/8 HIGH BLACK GOTHIC, LOCATED AS SHOWN.

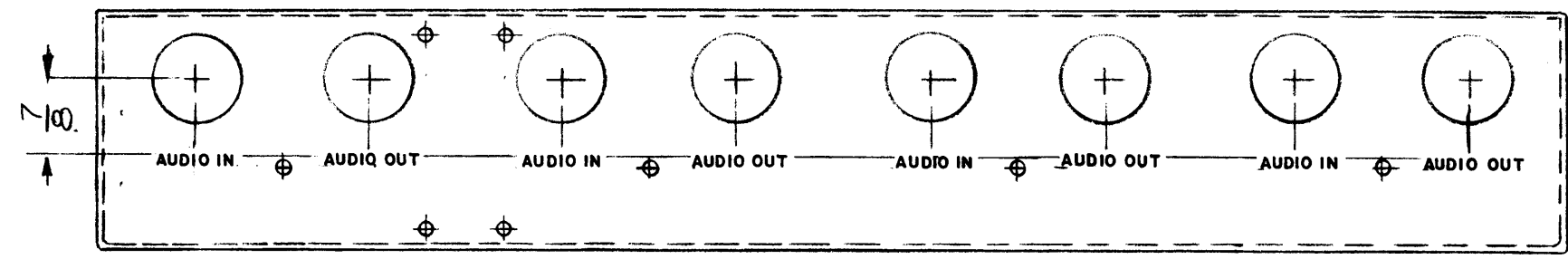

REF-MS-3617

REQ'D.	ITEM	PART NUMBER	DESCRIPTION	SYMBOL
AALTONEN		LIST OF MATERIAL		
MATERIAL		THE TECHNICAL MATERIEL CORP. MAMARONECK, NEW YORK		
FINISH		TITLE MARKING, CHASSIS, ELECTRICAL, MAIN MARKING PROCESS: AS PER TMC S-727		
UNLESS OTHERWISE SPECIFIED DIMENSIONS ARE IN INCHES AND INCLUDE CHEMICALLY APPLIED OR PLATED FINISHES		DRAWN G.D.L.	DATE 12-11-63	FINAL APPROVAL [Signature]
		CHECKED @	DATE 4-23-64	DATE 4/29/64
		ELECT. DES. [Signature]	DATE 4/23/64	LD-1427
		MECH. DES. [Signature]	DATE 4-23-64	0
		SHEET		REV. LTR.

Q'TY./UNIT	MODEL USED ON	ASS'Y. NO.
1	MAF-1	
SCALE 1:2	CODE A	
THE CONTENTS OF THIS DRAWING ARE THE EXCLUSIVE PROPERTY OF THE TECHNICAL MATERIEL CORP. ITS UNAUTHORIZED USE OR REPRODUCTION IN WHOLE OR IN PART IS STRICTLY FORBIDDEN.		

NOTES

LD-1428	REVISIONS						
	SYM	DESCRIPTION	DATE	E.M.N. NO.	DRAFT	CHKD	APPD
0	0	ORIGINAL RELEASE FOR PRODUCTION	4/24/64	0	A.M.	@	

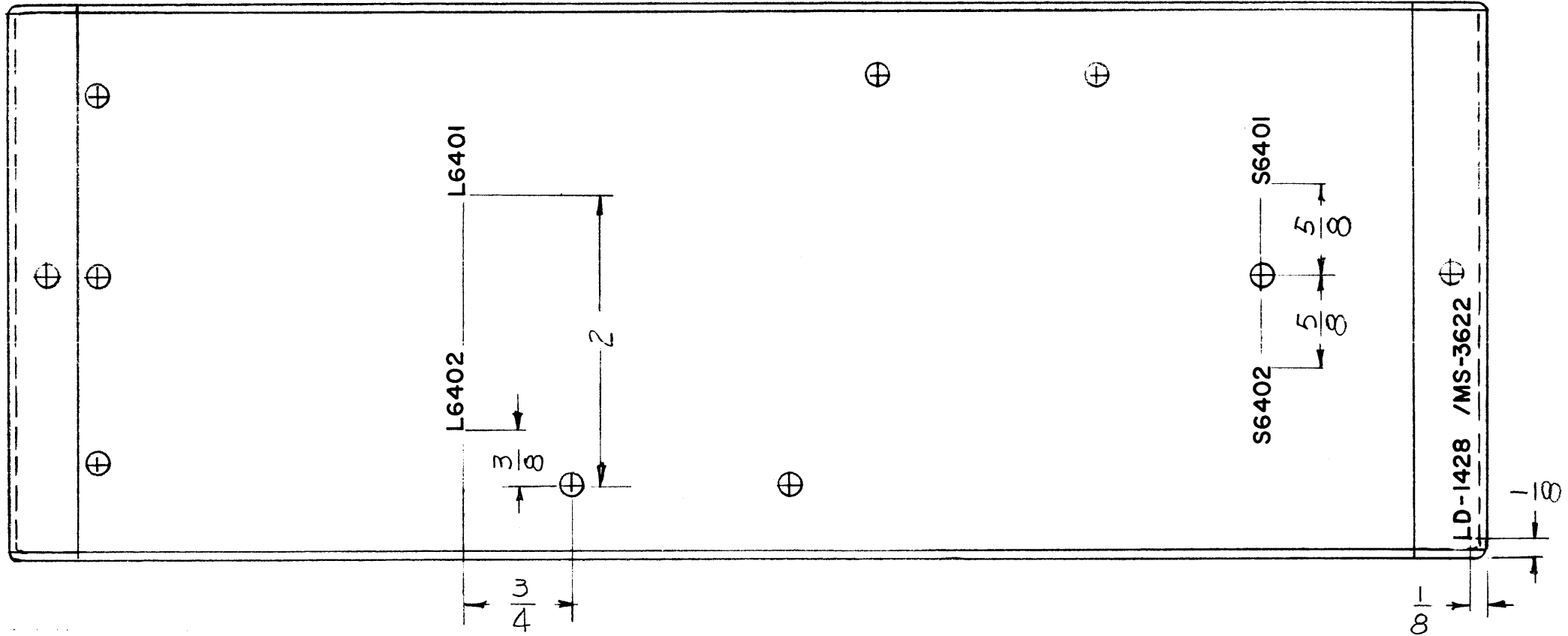
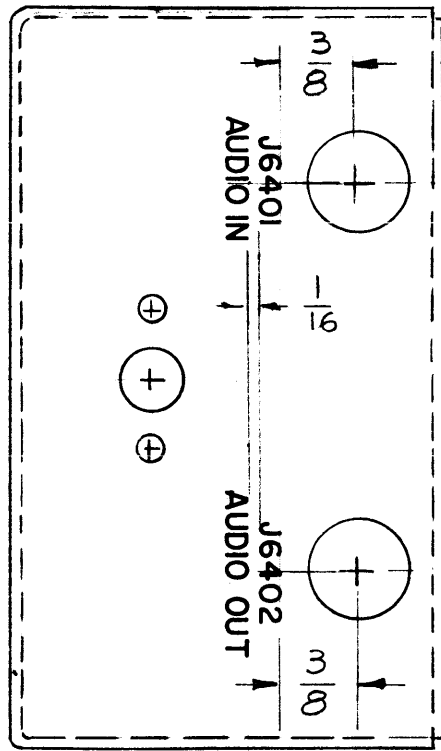

MARKING PROCESS: AS PER TMC SPECIFICATION S-727.
 LETTERING: 1/8 HIGH BLACK GOTHIC, LOCATED AS SHOWN.

REF - MS-3622

4	MAF-1	
Q'TY./UNIT	MODEL USED ON	ASS'Y. NO.
SCALE 1:1	CODE A	

THE CONTENTS OF THIS DRAWING ARE THE EXCLUSIVE PROPERTY OF THE TECHNICAL MATERIEL CORP. ITS UNAUTHORIZED USE OR REPRODUCTION IN WHOLE OR IN PART IS STRICTLY FORBIDDEN.

REQ'D.	ITEM	PART NUMBER	DESCRIPTION	SYMBOL
AALTONEN		LIST OF MATERIAL		
MATERIAL		THE TECHNICAL MATERIEL CORP. MAMARONECK, NEW YORK		
FINISH		TITLE MARKING, CHASSIS, ELECTRICAL, MAIN MARKING PROCESS: AS PER TMC S-727		
UNLESS OTHERWISE SPECIFIED DIMENSIONS ARE IN INCHES AND INCLUDE CHEMICALLY APPLIED OR PLATED FINISHES		DRAWN G.D.L.	DATE 12-12-63	FINAL APPROVAL RPL
DECIMALS .X ± .05 .XX ± .01 .XXX ± .005		CHECKED @	DATE 6-23-64	DATE 4/29/64
FRACTIONS ± 1/64 ANGLES ± 0° 30'		ELECT. DES. TRC	DATE 4/23/64	LD-1428
TOLERANCES		MECH. DES. [Signature]	DATE 4-23-64	0
SHEET				REV. LTR.

NOTES

LD 1429

REVISIONS

SYM	DESCRIPTION	DATE	E.M.N. NO.	DRAFT	CHKD	APPD
X	EXPERIMENTAL RELEASE	3-24-64		A.M.		
Ø	ORIGINAL RELEASE FOR PRODUCTION	6-10-65		JC		

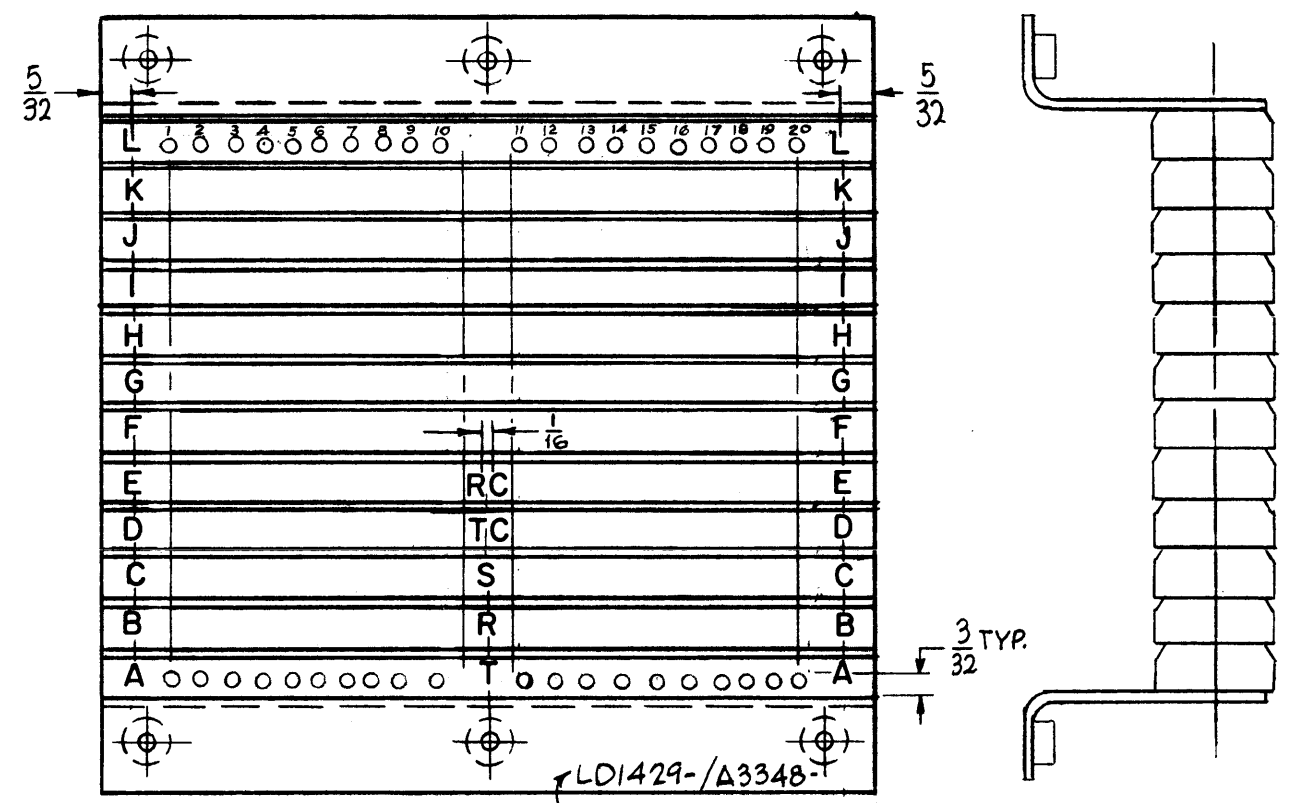

TOP VIEW
 MARK TMC PT. NO 1/8 HIGH BLACK GOTHIC W/LATEST REV. LETTERS.

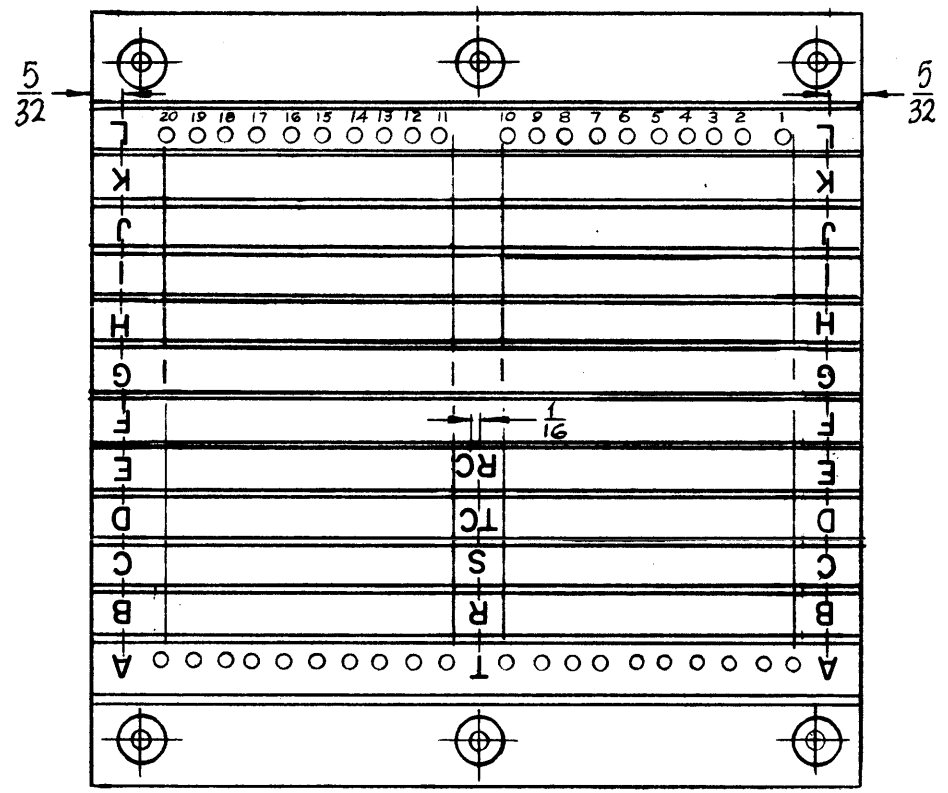

BOTTOM VIEW

UNLESS OTHERWISE SPECIFIED:
 LETTERING TO BE 1/8 HIGH
 WHITE GOTHIC PER TMC SPEC. S-727
 LOCATED AS SHOWN

REF: A-3348

I	LPP-4	
Q'TY./UNIT	MODEL USED ON	ASS'Y. NO.
SCALE 1:1	CODE	
THE CONTENTS OF THIS DRAWING ARE THE EXCLUSIVE PROPERTY OF THE TECHNICAL MATERIEL CORP. ITS UNAUTHORIZED USE OR REPRODUCTION IN WHOLE OR IN PART IS STRICTLY FORBIDDEN.		

REQ'D.	ITEM	PART NUMBER	DESCRIPTION	SYMBOL
I. JOHNSON LIST OF MATERIAL				
MATERIAL		THE TECHNICAL MATERIEL CORP. MAMARONECK, NEW YORK		
FINISH		TITLE MARKING, TERMINAL BOARD ASSEMBLY MARKING METHOD: PER TMC SPEC S-727		
UNLESS OTHERWISE SPECIFIED DIMENSIONS ARE IN INCHES AND INCLUDE CHEMICALLY APPLIED OR PLATED FINISHES		DRAWN A. MARINO	DATE 3-24-64	FINAL APPROVAL <i>[Signature]</i>
DECIMALS .X ± .05 .XX ± .01 .XXX ± .005		CHECKED <i>[Signature]</i>	DATE 6-10-65	DATE 10/14/65
FRACTIONS ± 1/64 ANGLES ± 0° 30'		ELECT. DES. <i>[Signature]</i>	DATE	DATE
TOLERANCES		MECH. DES. <i>[Signature]</i>	DATE	DATE
			LD 1429	Ø
			SHEET	REV. LTR.

NOTES

LD-1441 O

REVISIONS

SYM	DESCRIPTION	DATE	E.M.N. NO.	DRAFT	CHKD	APPD
O	ORIGINAL RELEASE FOR PRODUCTION	4/29/64	O	A.M.	ⓐ	

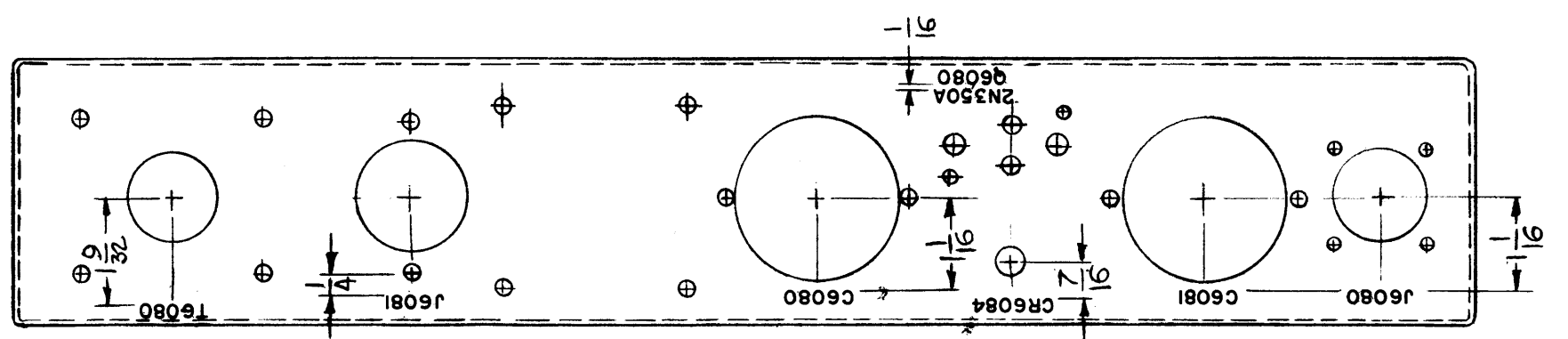
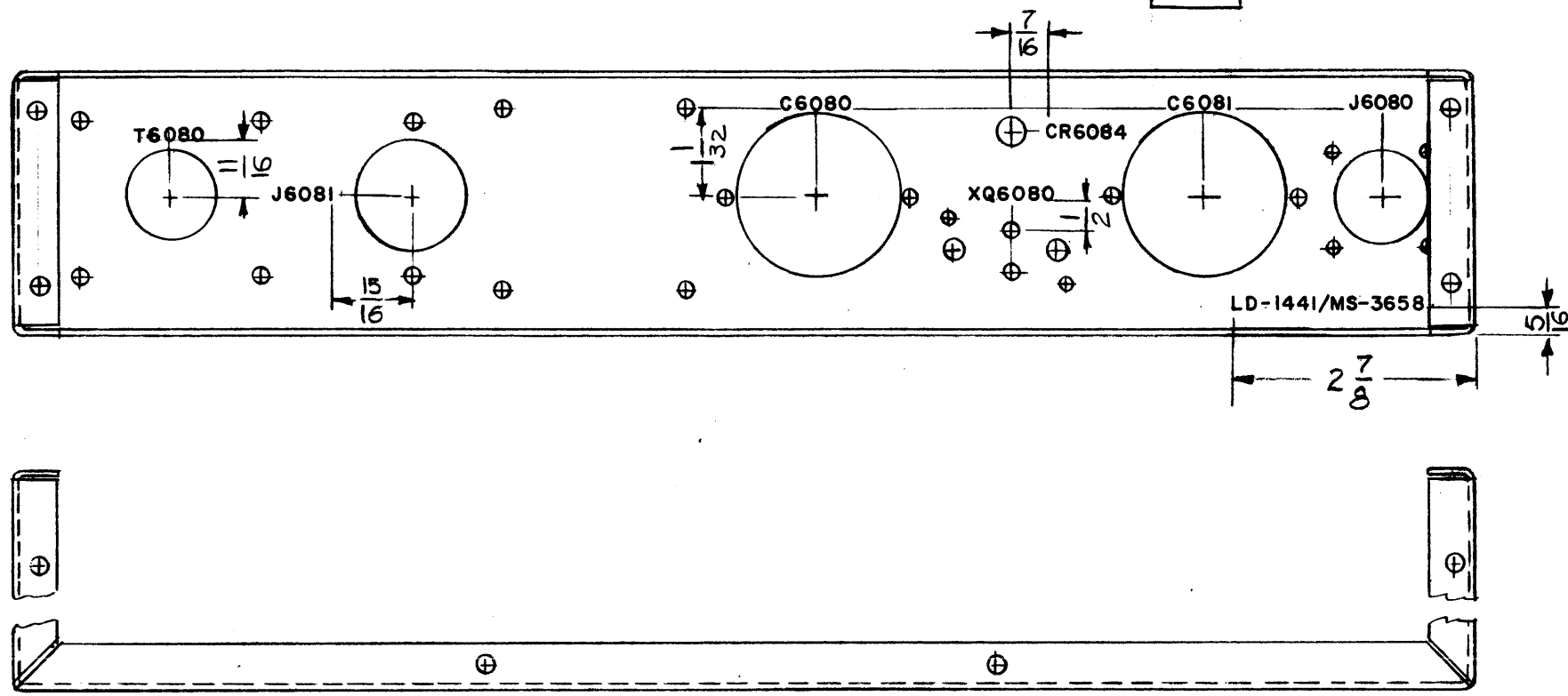

REF.: MS-3658

MARKING PROCESS: AS PER TMC SPECIFICATION S-727.
LETTERING: 1/8 HIGH BLACK GOTHIC, LOCATED AS SHOWN.

1	MPS-1	
Q'TY./UNIT	MODEL USED ON	ASS'Y. NO.
SCALE 1:2	CODE A	

THE CONTENTS OF THIS DRAWING ARE THE EXCLUSIVE PROPERTY OF THE TECHNICAL MATERIEL CORP. ITS UNAUTHORIZED USE OR REPRODUCTION IN WHOLE OR IN PART IS STRICTLY FORBIDDEN.

REQ'D.	ITEM	PART NUMBER	DESCRIPTION	SYMBOL
ALTONEN LIST OF MATERIAL				
MATERIAL			THE TECHNICAL MATERIEL CORP. MAMARONECK, NEW YORK	
FINISH			TITLE MARKING, CHASSIS, ELECTRICAL, MAIN MARKING PROCESS: AS PER TMC SPEC. S-727	
UNLESS OTHERWISE SPECIFIED DIMENSIONS ARE IN INCHES AND INCLUDE CHEMICALLY APPLIED OR PLATED FINISHES		DRAWN G.D.L.	DATE 1-2-64	FINAL APPROVAL RDL
DECIMALS .X ± .05 .XX ± .01 .XXX ± .005		CHECKED ⓐ	DATE 3-14-64	
FRACTIONS ± 1/64 ANGLES ± 0° 30'		ELECT. DES. TJA	DATE 3/14/64	LD-1441
TOLERANCES		MECH. DES. MJS	DATE 2-20-64	O
			SHEET	REV. LTR.

NOTES

LD-1443

REVISIONS

SYM	DESCRIPTION	DATE	E.M.N. NO.	DRAFT	CHKD	APPD
Ø	ORIGINAL RELEASE FOR PRODUCTION	7-1-64	Ø			

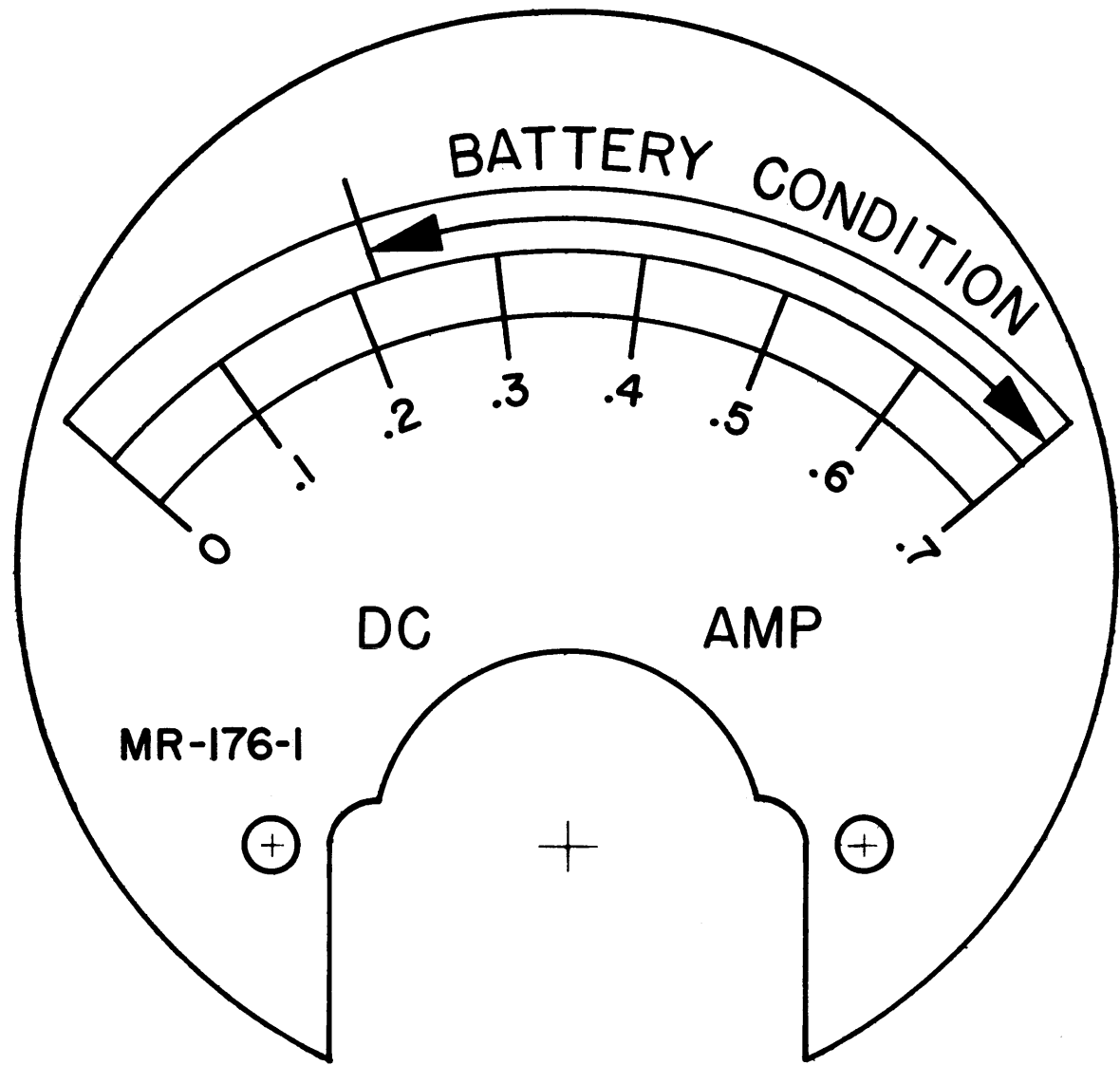

SCALE : 3:1

THE ORIGINAL ARTWORK TO BE SUPPLIED BY TMC FOR PHOTOGRAPHING (SCALE - 3:1).

NOTES

I	BPS-1	
Q'TY./UNIT	MODEL USED ON	ASS'Y. NO.
SCALE	CODE	
—H—	A	

THE CONTENTS OF THIS DRAWING ARE THE EXCLUSIVE PROPERTY OF THE TECHNICAL MATERIEL CORP. ITS UNAUTHORIZED USE OR REPRODUCTION IN WHOLE OR IN PART IS STRICTLY FORBIDDEN.

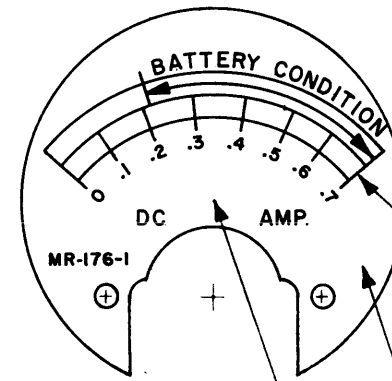

- NOTE:
- 1- ALL LETTERS, NUMBERS, DOTS AND LINE WORK TO BE BLACK.
 - 2-BACKGROUND TO BE WHITE.
 - 3-TMC INSIGNIA (NP-117) TO BE BLACK.

SCALE: 1:1



REF: MR-176-1

REQ'D.	ITEM	PART NUMBER	DESCRIPTION	SYMBOL
M. GELLMAN		LIST OF MATERIAL		
MATERIAL		THE TECHNICAL MATERIEL CORP. MAMARONECK, NEW YORK		
FINISH		TITLE METER, LEVEL INDICATING		
UNLESS OTHERWISE SPECIFIED DIMENSIONS ARE IN INCHES AND INCLUDE CHEMICALLY APPLIED OR PLATED FINISHES		DRAWN <i>G. Soren</i>	DATE 1-2-64	FINAL APPROVAL <i>[Signature]</i>
		CHECKED @	DATE 7-1-64	
DECIMALS .X ± .05 .XX ± .01 .XXX ± .005		FRACTIONS ± 1/64 ANGLES ± 0° 30'		
TOLERANCES		ELECT. DES. <i>[Signature]</i>		DATE 7-1-64
		MECH. DES.		DATE
		SHEET		REV. LTR.
				LD-1443

NOTES

TMC SPECIFICATION S-113
FUNGUS PROOFING PER

MARKING PROCESS: AS PER TMC SPECIFICATION S-727.
LETTERING: 1/8 HIGH BLACK GOTHIC, LOCATED AS SHOWN.

THE CONTENTS OF THIS DRAWING ARE THE EXCLUSIVE PROPERTY OF THE TECHNICAL MATERIEL CORP. ITS UNAUTHORIZED USE OR REPRODUCTION IN WHOLE OR IN PART IS STRICTLY FORBIDDEN.

SCALE	1" = 1"
QTY./UNIT	1
MODEL USED ON	GPT-10K (17(A)505)
ASSY. NO.	A-3479
CODE	A

DECIMALS
X ± .05
XX ± .01
XXX ± .005

UNLESS OTHERWISE SPECIFIED
DIMENSIONS ARE IN INCHES AND INCLUDE
CHEMICALLY APPLIED OR PLATED FINISHES

FRACTIONS
± 1/64
± 1/32
± 0.30/

REV. LTR.	DATE	BY
A	2/27/64	WJC
	DATE	BY
	2/27/64	JH
DATE	CHECKED	BY
5-6-64	John C. Biele	JCB
DATE	DRAWN	BY
2-8-64	John C. Biele	JCB
DATE	FINAL APPROVAL	BY
5-6-64	KJC	

MATERIAL
FINISH
TITLE
MARKING, BOARD, COMP. MTG.
MAMARONECK, NEW YORK
THE TECHNICAL MATERIEL CORP.

LIST OF MATERIAL

REQ'D.	ITEM	PART NUMBER	DESCRIPTION	SYMBOL
--------	------	-------------	-------------	--------

REF: PX-796-

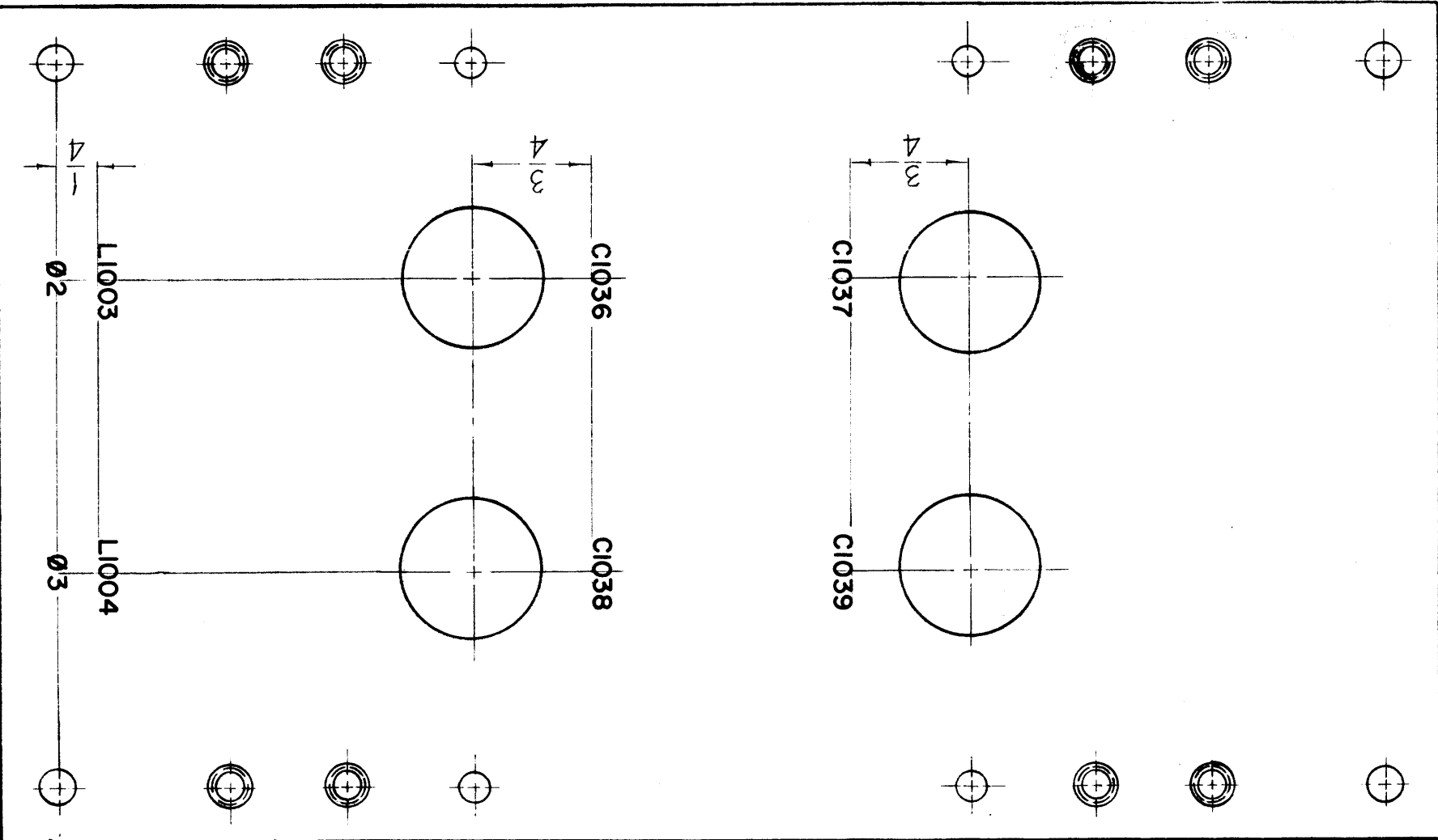

LD-1451 A

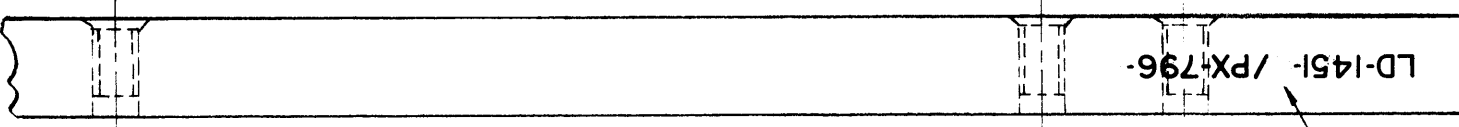

STAMP TMC PART NO. W/LATEST
REVISION LETTERS

SYM	DESCRIPTION	DATE	E.M.N. NO.	DRAFT	CHKD	APPD
A	4 CORNER HOLES WERE C/BORE	5/17/64		AM	JH	JH
O	ORIGINAL RELEASE FOR PRODUCTION	5/6/64				

REVISIONS

LD-1455 0

REVISIONS

SYM	DESCRIPTION	DATE	E.M.N. NO.	DRAFT	CHKD	APPD
0	ORIGINAL RELEASE FOR PRODUCTION	5/26/64	0	A.M.		

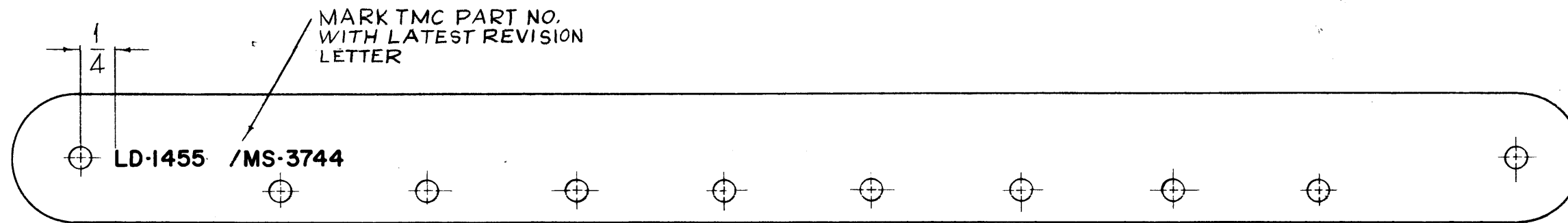
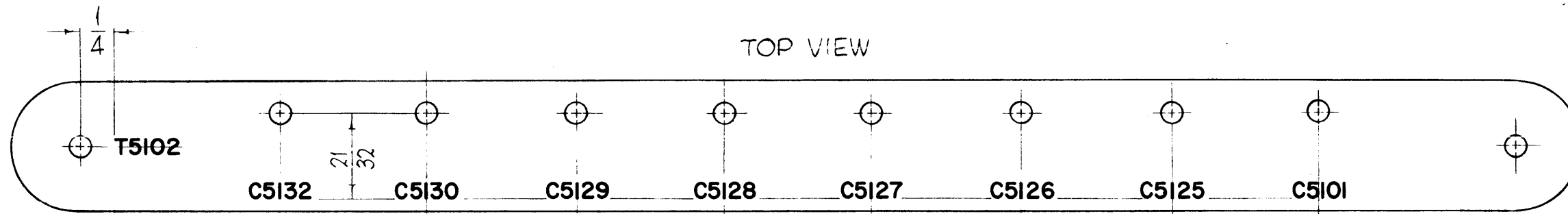

REF-TMC DWG. NO. MS-3744

MARKING PROCESS: AS PER TMC SPECIFICATION S-727.
 LETTERING: 1/8 HIGH BLACK GOTHIC, LOCATED AS SHOWN.

1	GPT-200K	AX-394
QTY./UNIT	MODEL USED ON	ASSY. NO.
SCALE #	CODE A	

THE CONTENTS OF THIS DRAWING ARE THE EXCLUSIVE PROPERTY OF THE TECHNICAL MATERIEL CORP. ITS UNAUTHORIZED USE OR REPRODUCTION IN WHOLE OR IN PART IS STRICTLY FORBIDDEN.

REQ'D.	ITEM	PART NUMBER	DESCRIPTION	SYMBOL
	F. BUDETTI		LIST OF MATERIAL	
MATERIAL		THE TECHNICAL MATERIEL CORP. MAMARONECK, NEW YORK		
FINISH		TITLE MARKING, GROUND STRAP MARKING METHOD: AS PER TMC SPEC. S727		
UNLESS OTHERWISE SPECIFIED DIMENSIONS ARE IN INCHES AND INCLUDE CHEMICALLY APPLIED OR PLATED FINISHES		DRAWN John C Biele	DATE 9/25/64	FINAL APPROVAL RJC
DECIMALS .X ± .05 .XX ± .01 .XXX ± .005		TOLERANCES		DATE 5/26/64
		FRACTIONS ± 1/64 ANGLES ± 0° 30'		DATE 5/26/64
		ELECT. DES. JCB		DATE 5/26/64
		MECH. DES. JMC		DATE 5/26/64
NOTES		SHEET		REV. LTR.
		LD-1455		0

LD-1456 0

REVISIONS

SYM	DESCRIPTION	DATE	E.M.N. NO.	DRAFT	CHKD	APPD
0	ORIGINAL RELEASE FOR PRODUCTION	5/26/64	0	A.M.		

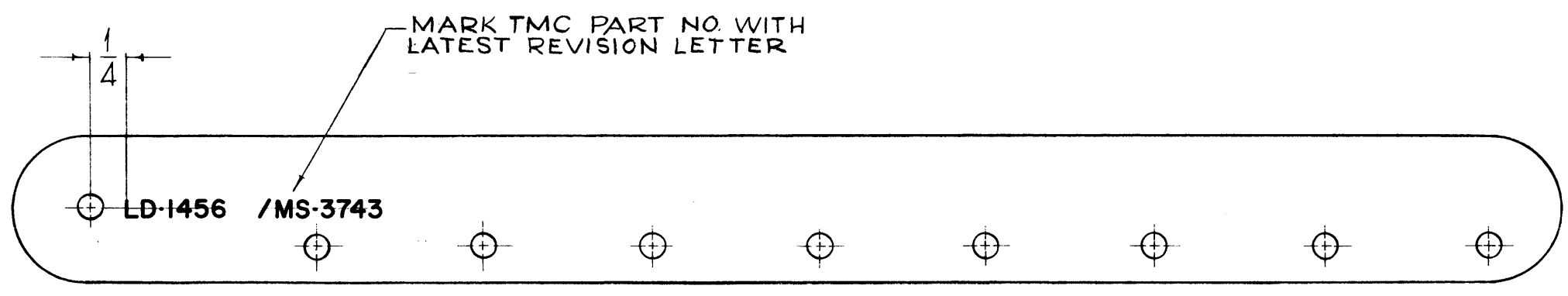
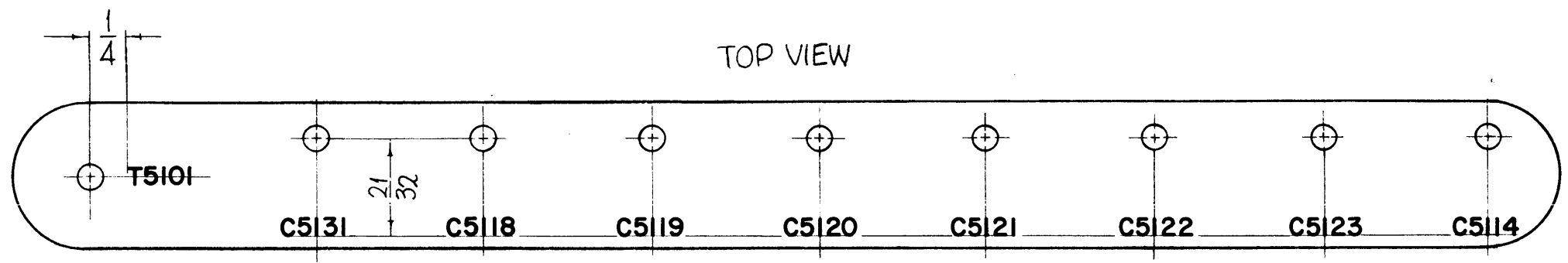

BOTTOM VIEW

REF-TMC DWG. NO. MS-3743

MARKING PROCESS: AS PER TMC SPECIFICATION S-727.
LETTERING: 1/8 HIGH BLACK GOTHIC, LOCATED AS SHOWN.

1	GPT-200K	AX-394
Q'TY./UNIT	MODEL USED ON	ASS'Y. NO.
#	A	

NOTES

THE CONTENTS OF THIS DRAWING ARE THE EXCLUSIVE PROPERTY OF THE TECHNICAL MATERIEL CORP. ITS UNAUTHORIZED USE OR REPRODUCTION IN WHOLE OR IN PART IS STRICTLY FORBIDDEN.

REQ'D.	ITEM	PART NUMBER	DESCRIPTION	SYMBOL
F. BUDETTI LIST OF MATERIAL				
MATERIAL		THE TECHNICAL MATERIEL CORP. MAMARONECK, NEW YORK		
FINISH		TITLE MARKING, GROUND STRAP MARKING METHOD: AS PER TMC SPEC. S-727		
UNLESS OTHERWISE SPECIFIED DIMENSIONS ARE IN INCHES AND INCLUDE CHEMICALLY APPLIED OR PLATED FINISHES		DRAWN John C Biele CHECKED aa ELECT. DES. JCB MECH. DES. we	DATE 4/22/64 DATE 4/13/64	FINAL APPROVAL [Signature] DATE SHEET LD-1456 0 REV. LTR.
DECIMALS .X ± .05 .XX ± .01 .XXX ± .05	TOLERANCES	FRACTIONS ± 1/64 ANGLES ± 0° 30'		

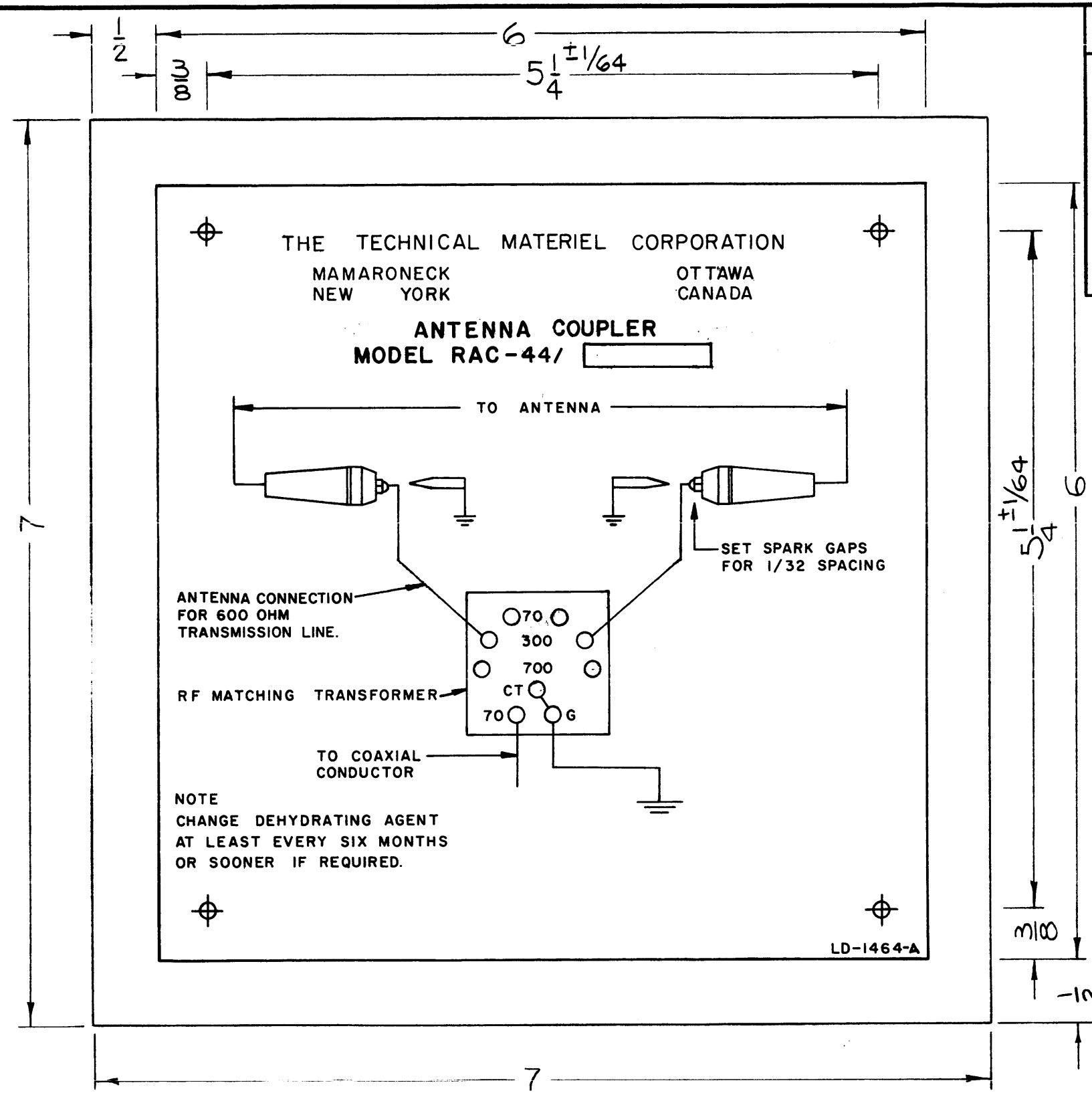

LD-1464 A

REVISIONS					
SYM	DESCRIPTION	DATE	E.M.N. NO.	DRAFT	CHKD
O	ORIGINAL RELEASE FOR PRODUCTION	3/5/64	*		
A	MODEL TITLE REVISED NOTE REVISED & UPDATED	7-21-64	11821	G.D.L.	

- NOTE:
- 1 ~ PRINTED DIRECTLY ON FACE OF PLASTIC.
 - 2 ~ MATERIAL: POLISHED WHITE OPAQUE VINYL PLASTIC .015 THK.
 - 3 ~ 3/16 X 1 BLOCK, AREA TO BE UNPOLISHED
 - 4 ~ MTG HOLES: 7/64(.109) DIA. 4 REQ

REQ'D.	ITEM	PART NUMBER	DESCRIPTION	SYMBOL
R. HAY				
LIST OF MATERIAL				
MATERIAL		THE TECHNICAL MATERIEL CORP. MAMARONECK, NEW YORK		
FINISH		TITLE SCHEMATIC DIAGRAM MODEL RAC-44		
UNLESS OTHERWISE SPECIFIED DIMENSIONS ARE IN INCHES AND INCLUDE CHEMICALLY APPLIED OR PLATED FINISHES		DRAWN J.E.G.	DATE 3-5-64	FINAL APPROVAL <i>[Signature]</i>
		CHECKED <i>[Signature]</i>	DATE 3-5-64	DATE 3/5/64
		ELECT. DES.	DATE	LD-1464
		MECH. DES.	DATE 3/5/64	A
			SHEET	REV. LTR.

1	RAC-44	
QTY./UNIT	MODEL USED ON	ASS'Y. NO.
SCALE	CODE	
	A	
THE CONTENTS OF THIS DRAWING ARE THE EXCLUSIVE PROPERTY OF THE TECHNICAL MATERIEL CORP. ITS UNAUTHORIZED USE OR REPRODUCTION IN WHOLE OR IN PART IS STRICTLY FORBIDDEN.		

NOTES

MARK TMC P/N 1/8 HIGH GOTHIC
(WHITE) WITH LATEST REVISION
LETTERS AS PER
TMC SPEC S727

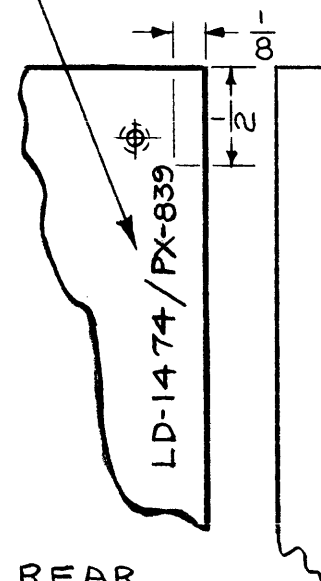

REAR
VIEW

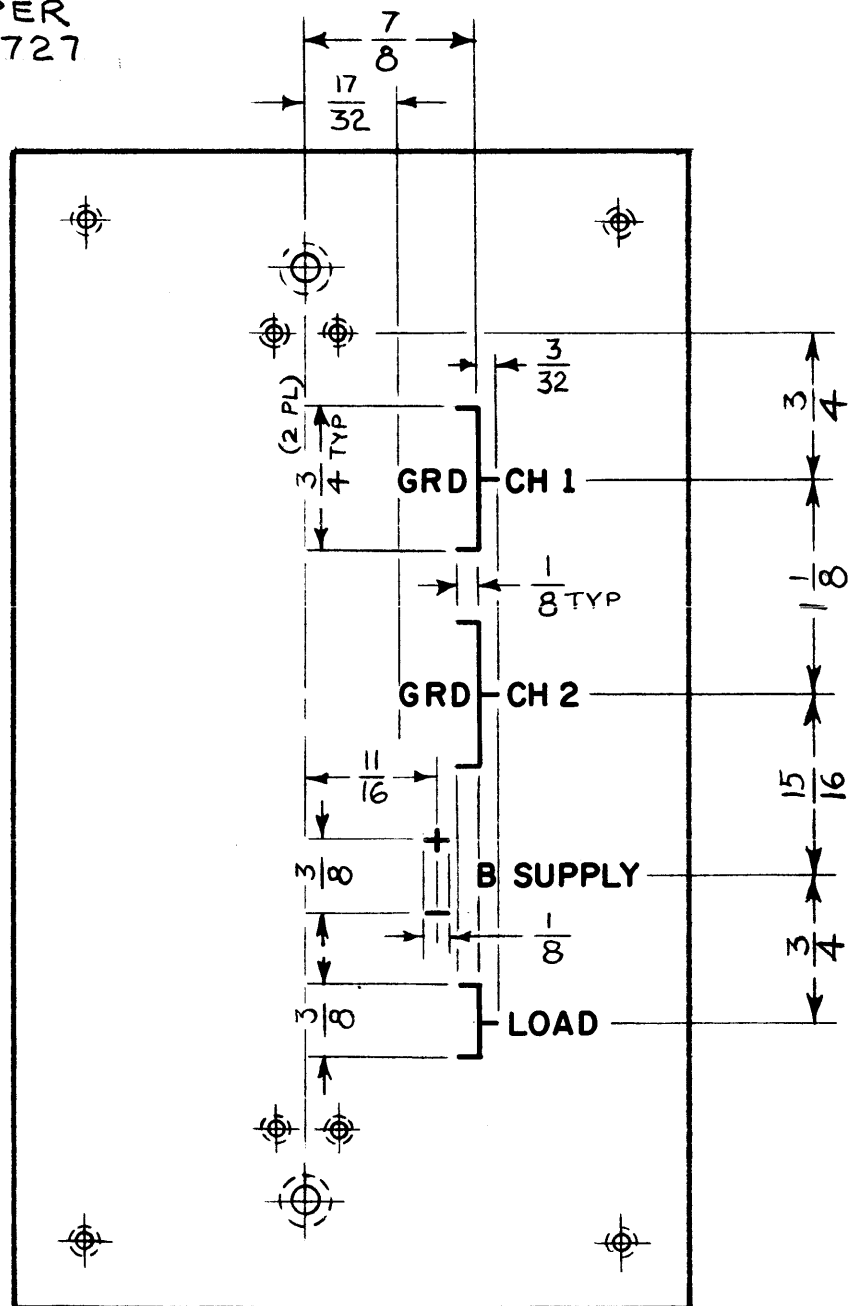

FRONT VIEW

LD-1474

REVISIONS

SYM	DESCRIPTION	DATE	E.M.N. NO.	DRAFT	CHKD	APPD
Ø	ORIGINAL RELEASE FOR PRODUCTION	6-10-65	-11	JC		

ENGRAVING		
LETTER HEIGHT	STROKE DEPTH	STROKE WIDTH
1/8	.010	.020
LINES	.010	.020

UNLESS OTHERWISE SPECIFIED:

1. ALL LETTERING TO BE GOTHIC, WHITE FILLED.
2. ALL LINES & SYMBOLS TO BE WHITE FILLED.
3. MARKING: TMC PART NO. ONLY AS PER TMC SPEC. S727
4. ALL ENGRAVING AS PER TMC SPEC. S566.

REF: PX-839

REQ'D.	ITEM	PART NUMBER	DESCRIPTION	SYMBOL
I. JOHNSON LIST OF MATERIAL				
MATERIAL		THE TECHNICAL MATERIEL CORP. MAMARONECK, NEW YORK		
FINISH		TITLE MARKING, BOARD, TERMINAL MARKING METHOD: ENGRAVING & S727		
UNLESS OTHERWISE SPECIFIED DIMENSIONS ARE IN INCHES AND INCLUDE CHEMICALLY APPLIED OR PLATED FINISHES		DRAWN <i>N. Peters</i>	DATE 2-25-64	FINAL APPROV <i>[Signature]</i>
		CHECKED <i>[Signature]</i>	DATE 6-10-65	DATE 6/10/65
		ELECT. DES. <i>[Signature]</i>	DATE	LD-1474
		MECH. DES. <i>[Signature]</i>	DATE	
DECIMALS .X ± .05 .XX ± .01 .XXX ± .05		FRACTIONS ± 1/64 ANGLES ± 0° 30'		REV. LTR. Ø

1	RAK-31B	A-3507
QTY./UNIT	MODEL USED ON	ASSY. NO.
SCALE 1:1	CODE	
THE CONTENTS OF THIS DRAWING ARE THE EXCLUSIVE PROPERTY OF THE TECHNICAL MATERIEL CORP. ITS UNAUTHORIZED USE OR REPRODUCTION IN WHOLE OR IN PART IS STRICTLY FORBIDDEN.		

NOTES

LD1495-1

REVISIONS

SYM	DESCRIPTION	DATE	EM N NO	DRAFT	CHKD	APPD
X	EXP. RELEASE	10-10-66	X			
X1	UPDATED & REV.	10-14-68	C.C.			
Ø	ORIGINAL RELEASE FOR PRODUCTION	5/22/69				

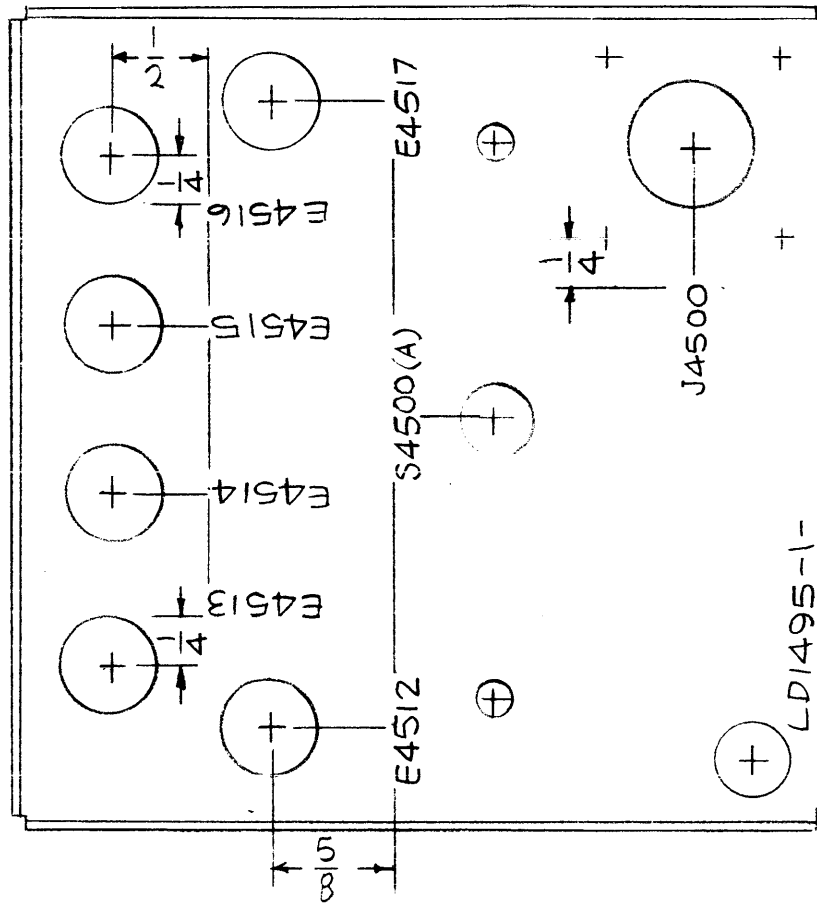
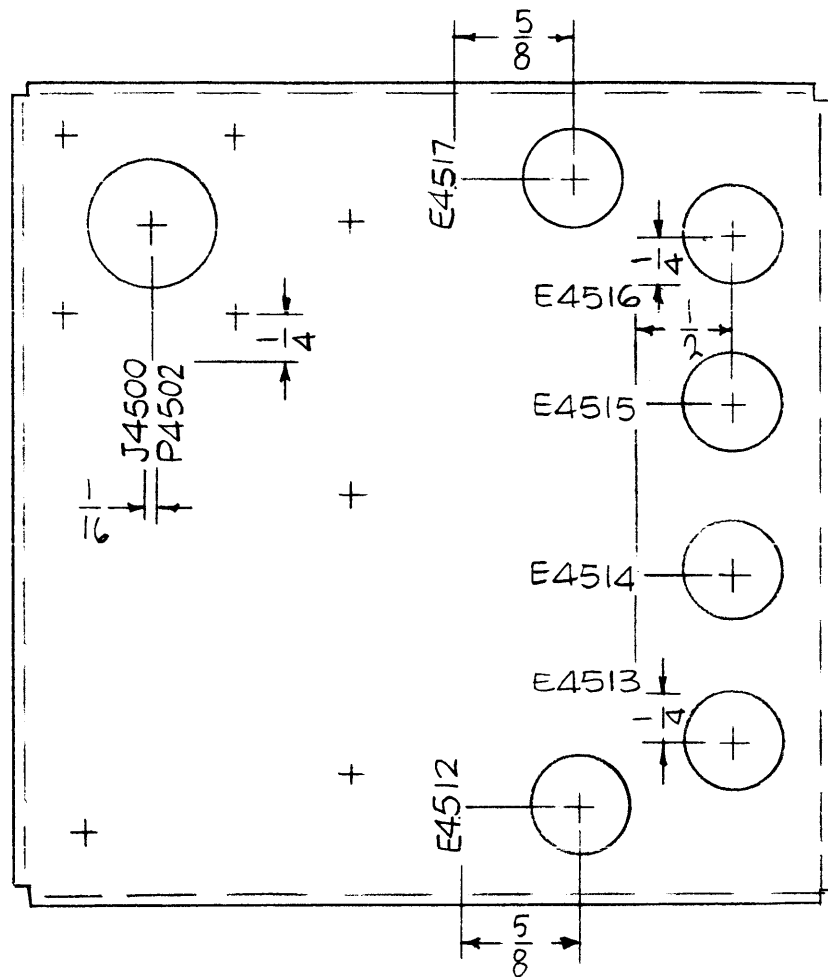

MARK TMC P/N
1/8 HIGH GOTHIC
W/LATEST REV.
LETTER.

MARKING PROCESS: AS PER TMC SPECIFICATION S-727.
LETTERING: 1/8 HIGH BLACK GOTHIC, LOCATED AS SHOWN

NOTES

Q'TY./UNIT	MODEL USED ON	ASS'Y. NO.
1	TFP 2.5K	
SCALE	CODE	S401-451
1:1	A	S401-
THE CONTENTS OF THIS DRAWING ARE THE EXCLUSIVE PROPERTY OF THE TECHNICAL MATERIEL CORP. ITS UNAUTHORIZED USE OR REPRODUCTION IN WHOLE OR IN PART IS STRICTLY FORBIDDEN.		

REF: MS 3753-

REQ'D.	ITEM	PART NUMBER	DESCRIPTION	SYMBOL
F. BUDETTI LIST OF MATERIAL				
MATERIAL		THE TECHNICAL MATERIEL CORP. MAMARONECK, NEW YORK		
FINISH		TITLE MARKING, PLATE FRONT, BANDSWITCH FILTER AS PER TMC SPEC. S727		
UNLESS OTHERWISE SPECIFIED DIMENSIONS ARE IN INCHES AND INCLUDE CHEMICALLY APPLIED OR PLATED FINISHES		DRAWN	DATE	FINAL APPROVAL
			9-28-66	
		CHECKED	DATE	
			10/10/66	
		ELECT. DES.	DATE	
		MECH. DES.	DATE	
			5-23-66	
LD1495-1				Ø
SHEET 1 OF 2				REV. LTR.

LD1495-2 Ø

REVISIONS						
SYM	DESCRIPTION	DATE	E.M.N. NO.	DRAFT	CHKD	APPD
X	EXP. RELEASE	10-10-66	X	<i>[Signature]</i>	<i>[Signature]</i>	<i>[Signature]</i>
X1	UPDATED & REV.	10-14-66	C.C.	<i>[Signature]</i>	<i>[Signature]</i>	<i>[Signature]</i>
Ø	ORIGINAL RELEASE FOR PRODUCTION	5/22/69		<i>[Signature]</i>		

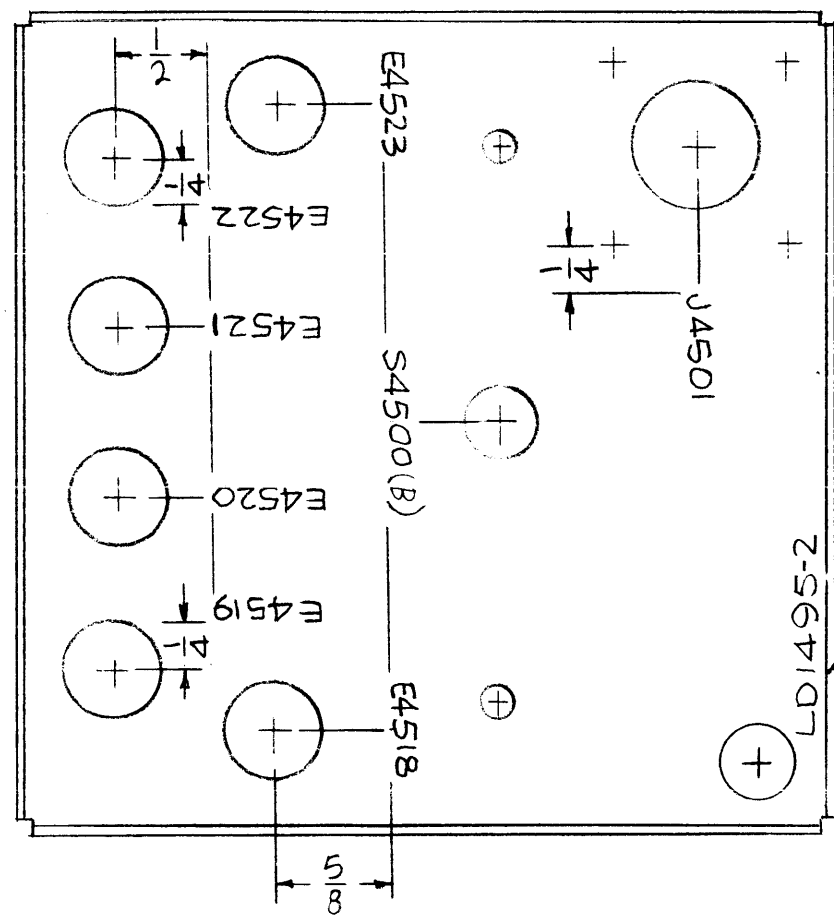
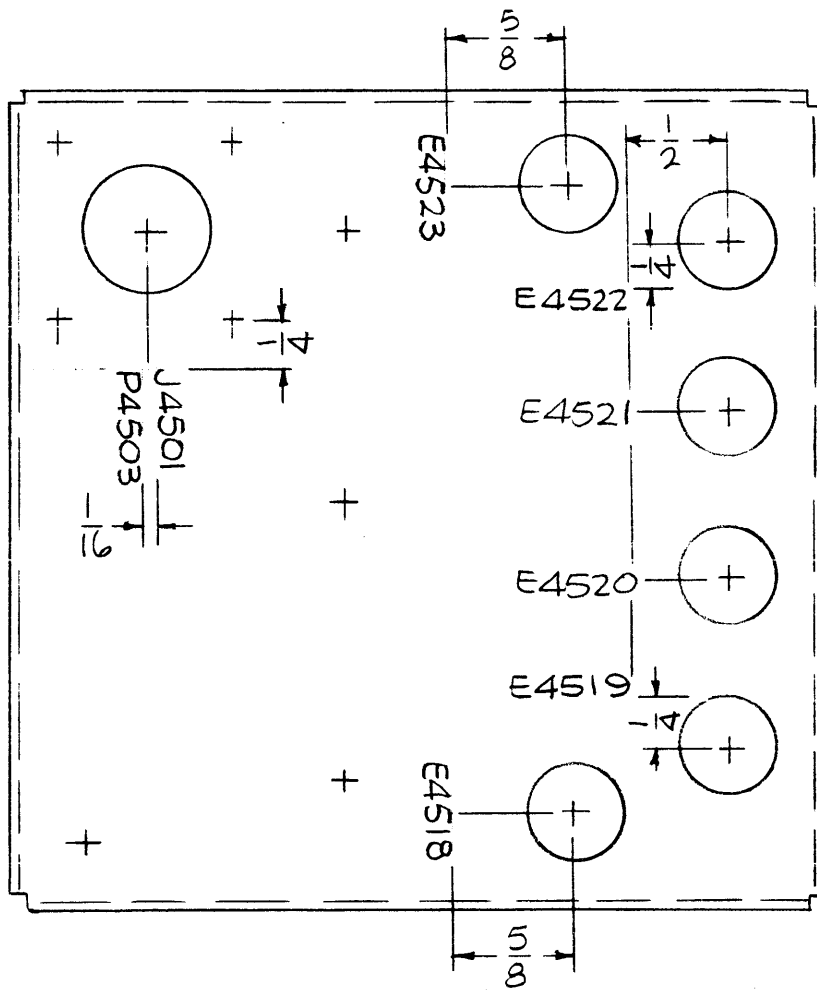

MARK TMC P/N
1/8 HIGH GOTHIC
W/LATEST REV
LETTER.

REF. MS3753-

REQ'D.	ITEM	PART NUMBER	DESCRIPTION	SYMBOL
F. BUDETTI LIST OF MATERIAL				
MATERIAL		THE TECHNICAL MATERIEL CORP. MAMARONECK, NEW YORK		
FINISH		TITLE MARKING, PLATE, REAR, BANDSWITCH FILTER. AS PER TMC SPEC. S727		
UNLESS OTHERWISE SPECIFIED DIMENSIONS ARE IN INCHES AND INCLUDE CHEMICALLY APPLIED OR PLATED FINISHES		DRAWN <i>[Signature]</i>	DATE 9-28-66	FINAL APPROVAL <i>[Signature]</i>
		CHECKED <i>[Signature]</i>	DATE 10/10/66	DATE 5/22/69
DECIMALS .X ± .05 .XX ± .01 .XXX ± .005		FRACTIONS ± 1/64 ANGLES ± 0° 30'		LD1495-2
TOLERANCES		MEMO DES. <i>[Signature]</i>		Ø
		DATE 5-22-69		SHEET 2 OF 2
				REV. LTR.

MARKING PROCESS: AS PER TMC SPECIFICATION S-727.

LETTERING: 1/8 HIGH BLACK GOTHIC, LOCATED AS SHOWN

NOTES

1	TFP-2.5K	ASS'Y. NO.
Q'TY./UNIT	MODEL USED ON	
SCALE 1:1	CODE A	S401-451 S401- S401-
THE CONTENTS OF THIS DRAWING ARE THE EXCLUSIVE PROPERTY OF THE TECHNICAL MATERIEL CORP. ITS UNAUTHORIZED USE OR REPRODUCTION IN WHOLE OR IN PART IS STRICTLY FORBIDDEN.		

REVISIONS

SYM	DESCRIPTION	DATE	E.M.N. NO.	DRAFT	CHKD	APPD
X	EXP. RELEASE	10-10-66				
XI	SWITCH REVISED	10-17-66				
Ø	ORIGINAL RELEASE FOR PRODUCTION	7/7/69				

MARK TMC P/N (LD1496)
 1/8 HIGH GOTHIC W/LATEST
 REV. LETTER. (ON REAR)

LD1496

ENGRAVING
 FRONT VIEW

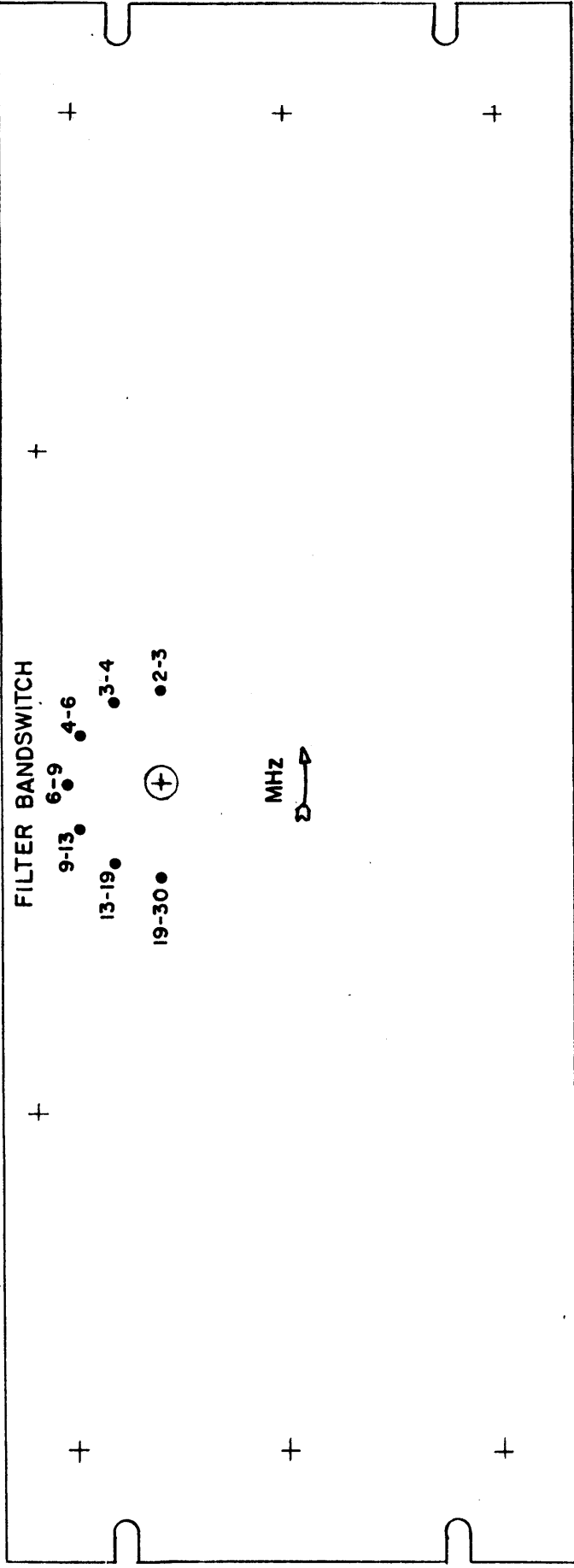

FILTER BANDSWITCH

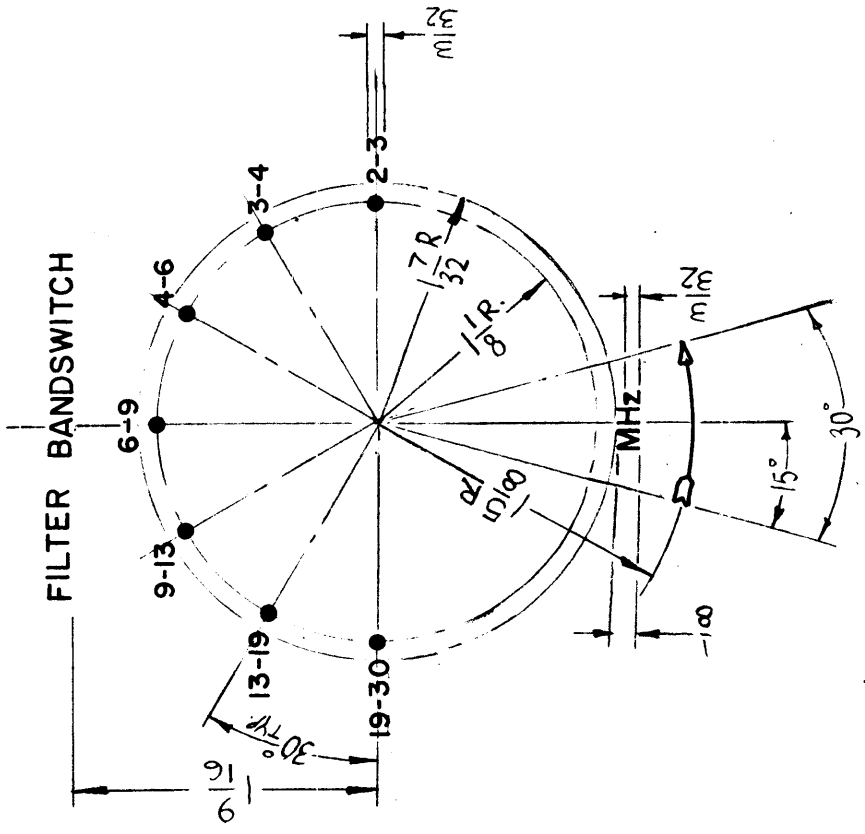

HEIGHT OF LETTERS	DEPTH OF STROKE	WIDTH OF STROKE
1/8	.010	.020
3/32	.010	.015
DOTS	.010	1/16 DIA.
LINES	.010	.015
ARROWS	.010	SEE NOTE 4

- 1. LETTERING TO BE 1/8 HIGH WHITE GOTHIC.
- 2. ALL DOTS & LINES TO BE WHITE FILLED.
- 3. ALL LETTER GROUPS TO BE CENTERED ON HOLES
- 4. ALL ARROWHEADS 3/32 X 53 WHITE OUTLINE FILLED, SEE DETAIL.
- 5. ALL ENGRAVING AS PER TMC SPEC S-566.

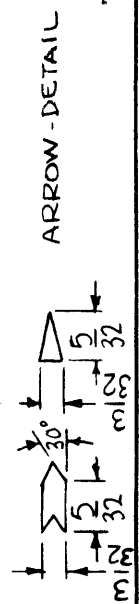

NOTES

REF: MS3755-

REQ'D.	ITEM	PART NUMBER	DESCRIPTION	SYMBOL
	F. BUDETTI		LIST OF MATERIAL	

MATERIAL	FINISH	UNLESS OTHERWISE SPECIFIED DIMENSIONS ARE IN INCHES AND INCLUDE CHEMICALLY APPLIED OR PLATED FINISHES	DECIMALS X ± .05 XX ± .01 XXX ± .005	TOLERANCES ± 1/64 ANGLES ± 0° 30'	FRACTIONS
THE TECHNICAL MATERIEL CORP. MAMARONECK, NEW YORK	MARKING, PANEL FRONT AS PER TMC SPEC S-566				

QTY./UNIT	MODEL USED ON	ASSY. NO.
1	TFP-25K	

SCALE	CODE	ASSY. NO.
DO NOT SCALE	A	S401-451

THE CONTENTS OF THIS DRAWING ARE THE EXCLUSIVE PROPERTY OF THE TECHNICAL MATERIEL CORP. ITS UNAUTHORIZED USE OR REPRODUCTION IN WHOLE OR IN PART IS STRICTLY FORBIDDEN.

REVISIONS

BYM	DESCRIPTION	DATE	EM.N. NO.	DRAFT	CHKD	APPD
X	EXP RELEASE	10-10-66	X	SRS	WN	CS
XI	OUTLINE REVERSED, CP4500 & P4500 RELOCATED	10-12-66	XI	CS	WN	CS
0	ORIGINAL RELEASE	5-2-66				

X. LD1497

MARK TMC P/N
HIGH GOTHIC
W/LATEST REK.
LETTER.

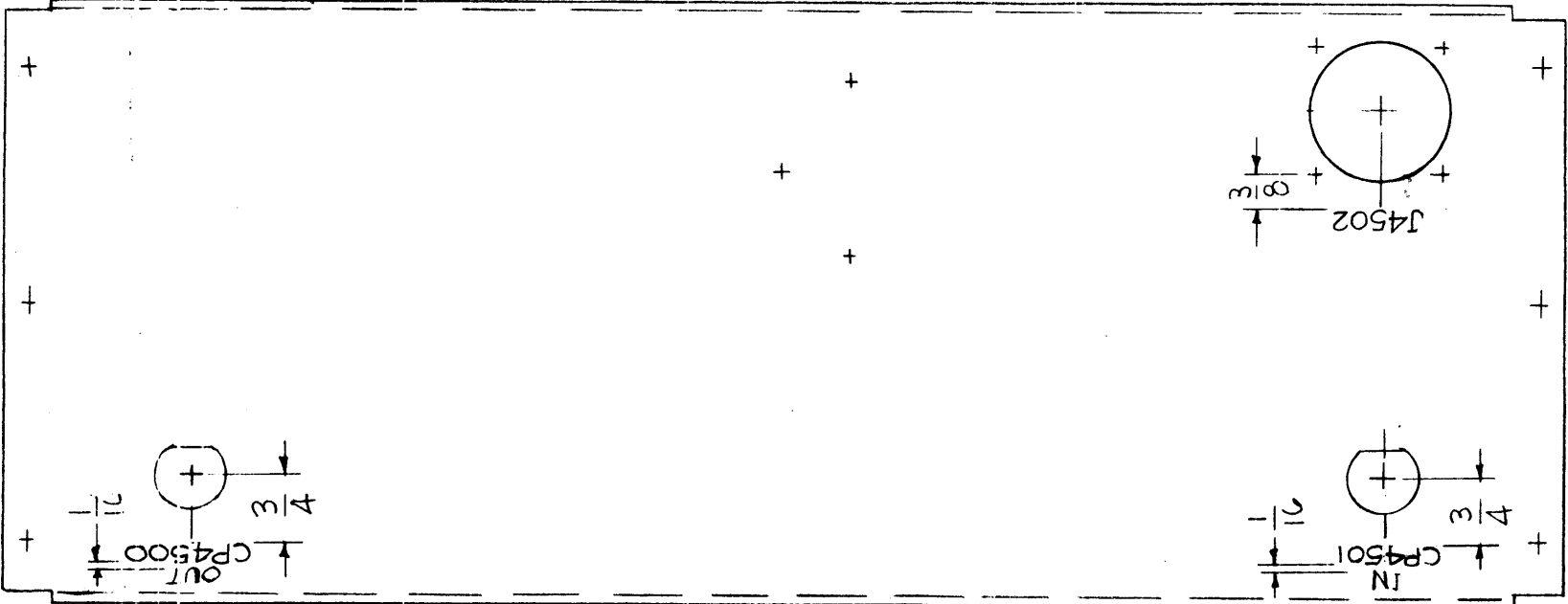
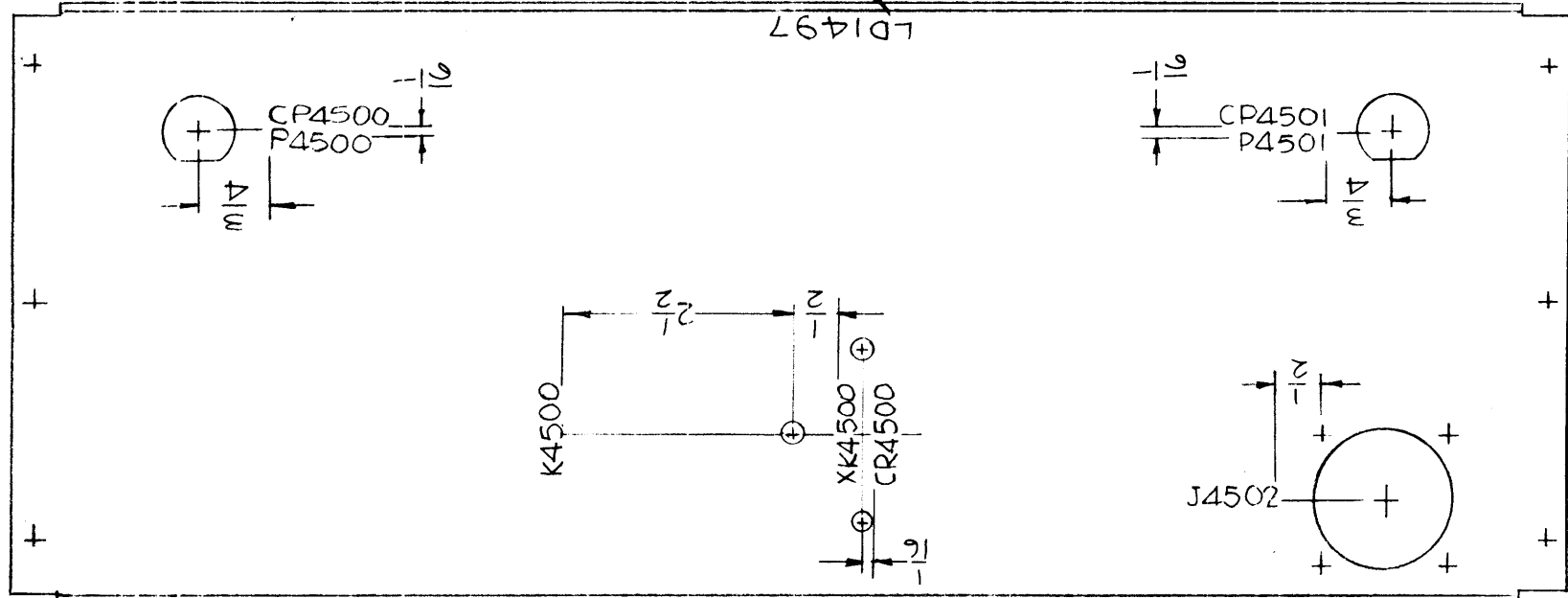

REF MS3757-

REQ'D.	ITEM	PART NUMBER	DESCRIPTION	SYMBOL
	F. BUDETTI		LIST OF MATERIAL	
MATERIAL				
FINISH				
UNLESS OTHERWISE SPECIFIED DIMENSIONS ARE IN INCHES AND INCLUDE CHEMICALLY APPLIED OR PLATED FINISHES				
DECIMALS .X ± .05				
FRACTIONS ± 1/64				
TOLERANCES .XX ± .01				
ANGLES ± 0° 30'				
TITILE MARKING, PLATE REAR FILTER DRAWER AS PER TMC SPEC. S727				
DRAWN DATE 9-27-66				
CHECKED DATE 5/9/73				
ELECT. DES. DATE				
MECH. DES. DATE				
SHEET LD1497				
REV. LTR. 0				

MARKING PROCESS: AS PER TMC SPECIFICATION S-727.

LETTERING: 1/8 HIGH BLACK GOTHIC, LOCATED AS SHOWN.

NOTES

THE CONTENTS OF THIS DRAWING ARE THE EXCLUSIVE PROPERTY OF THE TECHNICAL MATERIEL CORP. ITS UNAUTHORIZED USE OR REPRODUCTION IN WHOLE OR IN PART IS STRICTLY FORBIDDEN.

X
LD1498

REVISIONS

SYM	DESCRIPTION	DATE	E.M.N. NO.	DRAFT	CHKD	APPD
X	EXP. RELEASE	10-10-66	X	<i>MB</i>	<i>WV</i>	<i>CS</i>
Ø	ORIGINAL RELEASE	5/19/73		CS		

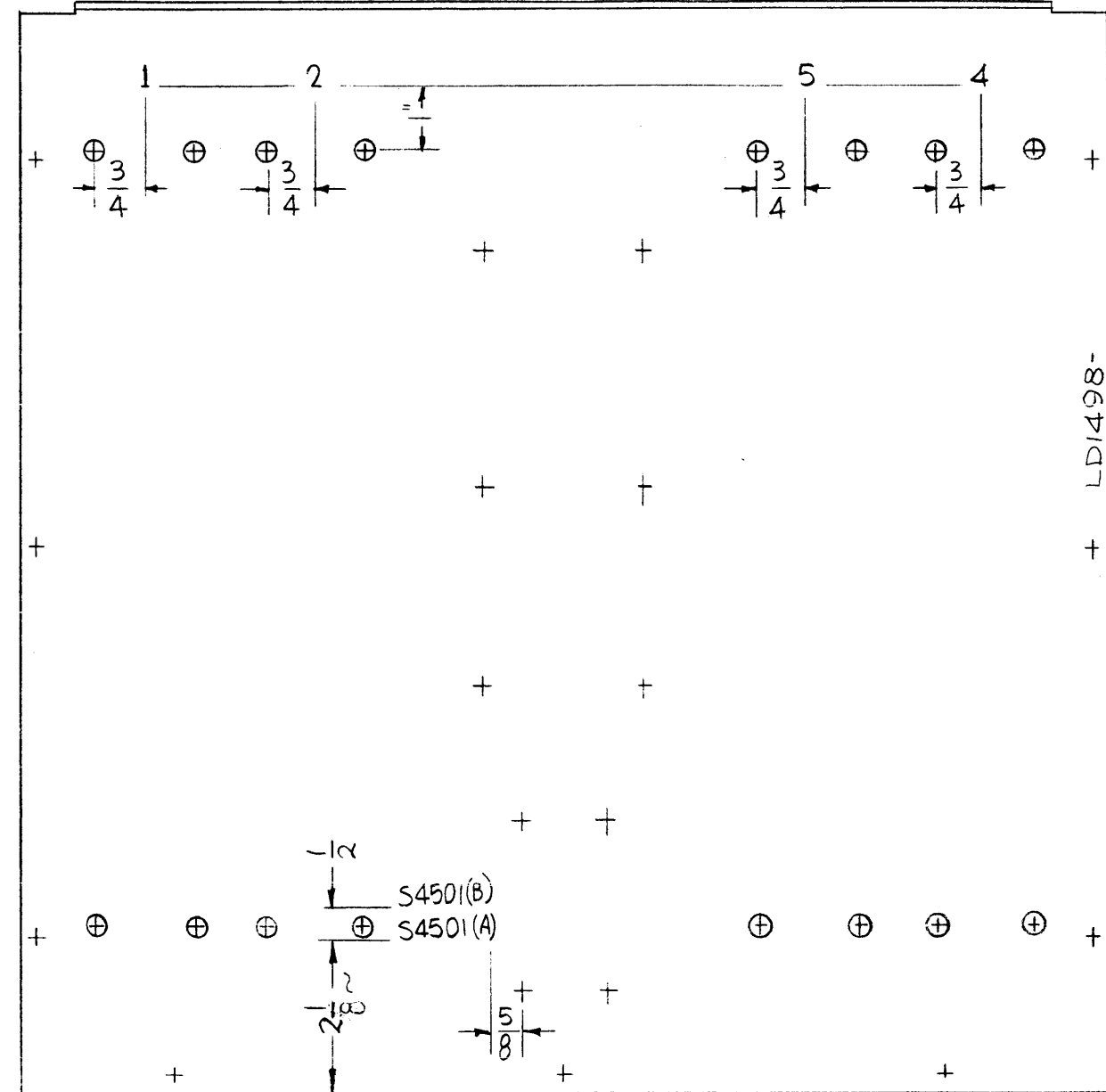

MARK TMC P/N
1/8 HIGH GOTHIC
W/LATEST REV.
LETTER.

LD1498-

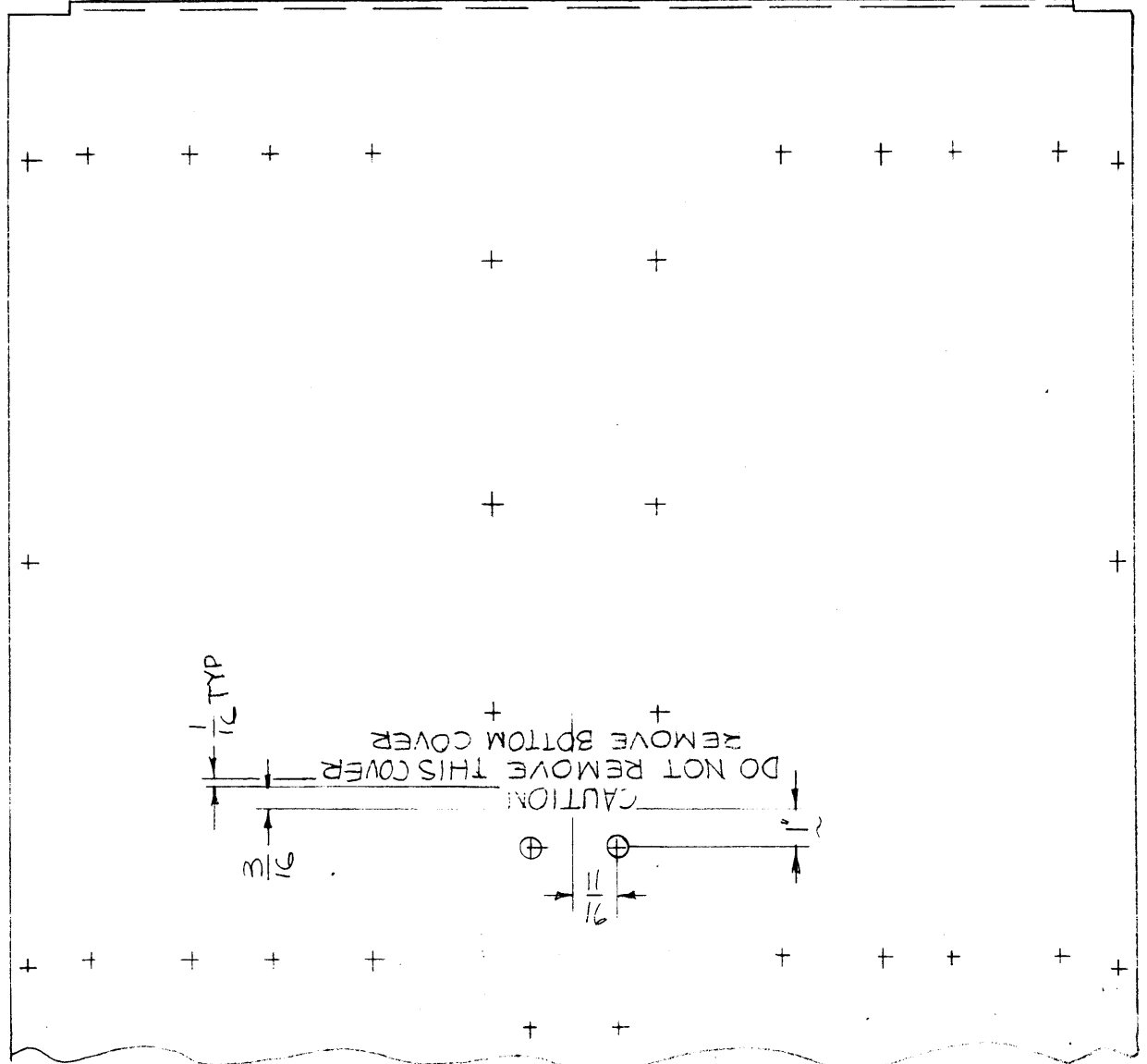

REF: MS3759-

NOTE: HOLES LEFT OFF
DUE TO CLARITY.

UNLESS OTHERWISE SPECIFIED:
MARKING PROCESS: AS PER TMC SPECIFICATION S-727.
LETTERING: 1/8 HIGH BLACK GOTHIC, LOCATED AS SHOWN.

NOTES

1	TFP-2.5K	
Q'TY./UNIT	MODEL USED ON	ASS'Y. NO.
SCALE 1:3	CODE A	S401-451 S401- S401-
THE CONTENTS OF THIS DRAWING ARE THE EXCLUSIVE PROPERTY OF THE TECHNICAL MATERIEL CORP. ITS UNAUTHORIZED USE OR REPRODUCTION IN WHOLE OR IN PART IS STRICTLY FORBIDDEN.		

REQ'D.	ITEM	PART NUMBER	DESCRIPTION	SYMBOL
F. BUDETTI LIST OF MATERIAL				
MATERIAL			THE TECHNICAL MATERIEL CORP. MAMARONECK, NEW YORK	
FINISH			TITLE MARKING, CHASSIS FILTER DRAWER AS PER TMC. SPEC. S-727	
UNLESS OTHERWISE SPECIFIED DIMENSIONS ARE IN INCHES AND INCLUDE CHEMICALLY APPLIED OR PLATED FINISHES		DRAWN <i>MB</i>	DATE 9-28-66	FINAL APPROVAL <i>CS</i>
DECIMALS .X ± .05 .XX ± .01 .XXX ± .005		CHECKED <i>CS</i>	DATE	DATE 5/19/73
FRACTIONS ± 1/64 ANGLES ± 0° 30'		ELECT. DES.	DATE	
TOLERANCES		MECH. DES.	DATE	
SHEET				REV. LTR.
LD1498				Ø

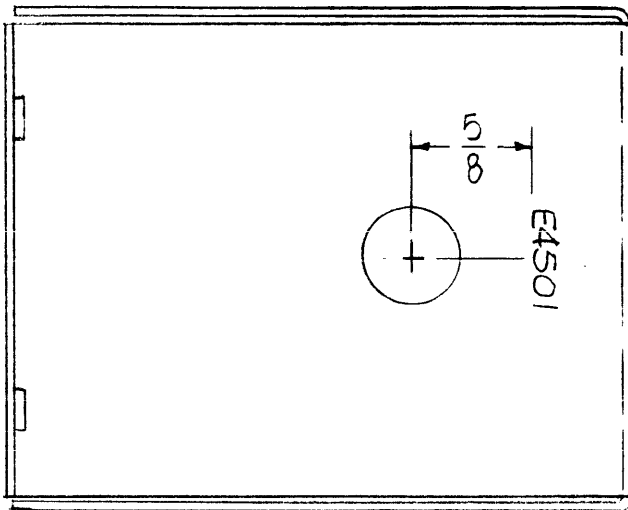

VIEW - A-A

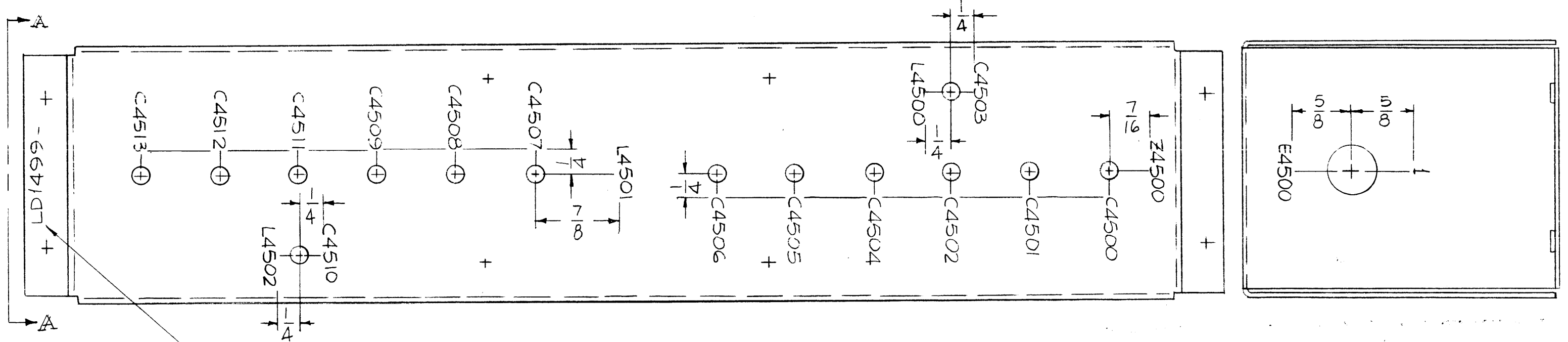

MARK TMC P/N
1/8 HIGH GOTHIC
W/LATEST REV
LETTER.

MARKING PROCESS: AS PER TMC SPECIFICATION S-727.

LETTERING: 1/8 HIGH BLACK GOTHIC, LOCATED AS SHOWN.

NOTES

1	TFP-2.5K	ASS'Y. NO.
Q'TY./UNIT	MODEL USED ON	
SCALE III	CODE A	S401-451 S401- S401-
THE CONTENTS OF THIS DRAWING ARE THE EXCLUSIVE PROPERTY OF THE TECHNICAL MATERIEL CORP. ITS UNAUTHORIZED USE OR REPRODUCTION IN WHOLE OR IN PART IS STRICTLY FORBIDDEN.		

REVISIONS						
SYM	DESCRIPTION	DATE	E.M.N. NO.	DRAFT	CHKD	APPD
X	EXP. RELEASE		X			
Ø	ORIGINAL RELEASE	5/9/73		CS		

LD1499

REF: M55066.

REQ'D.	ITEM	PART NUMBER	DESCRIPTION	SYMBOL
F. BUDETTI LIST OF MATERIAL				
MATERIAL			THE TECHNICAL MATERIEL CORP. MAMARONECK, NEW YORK	
FINISH			TITLE MARKING BOX, FILTER AS PER TMC SPEC, S-727	
UNLESS OTHERWISE SPECIFIED DIMENSIONS ARE IN INCHES AND INCLUDE CHEMICALLY APPLIED OR PLATED FINISHES			DRAWN <i>[Signature]</i>	DATE 9-30-66
DECIMALS .X ± .05 .XX ± .01 .XXX ± .005			CHECKED <i>[Signature]</i>	DATE
FRACTIONS ± 1/64 ANGLES ± 0° 30'			ELECT. DES.	DATE
TOLERANCES			MECH. DES.	DATE
			FINAL APPROVAL <i>[Signature]</i> DATE 5/9/73	
			SHEET	
			REV. LTR. LD1499	