

REVISIONS							
ZONE	SYM	DESCRIPTION	DATE	E.M.N. NO.	DRAFT	CHKD	APPD
	X1	REARRANGED LETTERING ON MULTIMETER	5-9-66	X1	NCA		
	X2	ON REAR MARKING, J1010 WAS J1002	5-10-66	M	Jc		
	X3	LETTERING L2081- ADDED	5-11-66	X3	G.D.L		
	X4	LETTERING REARRANGED ON MULTIMETER	5-13-66	X4	WMS		
	X5	J1012 WAS J1010	8-22-66	X5	JBC		
	X6	LINE VOLTAGE WAS X10	9-15-66	X6	RME		
	X7	ON "TTY MONITOR" & "POWER ON" V/L DIM WAS 3/32	9-23-66		Jc		
	Ø	ORIGINAL RELEASE FOR PRODUCTION	9-27-66	Ø	RME		

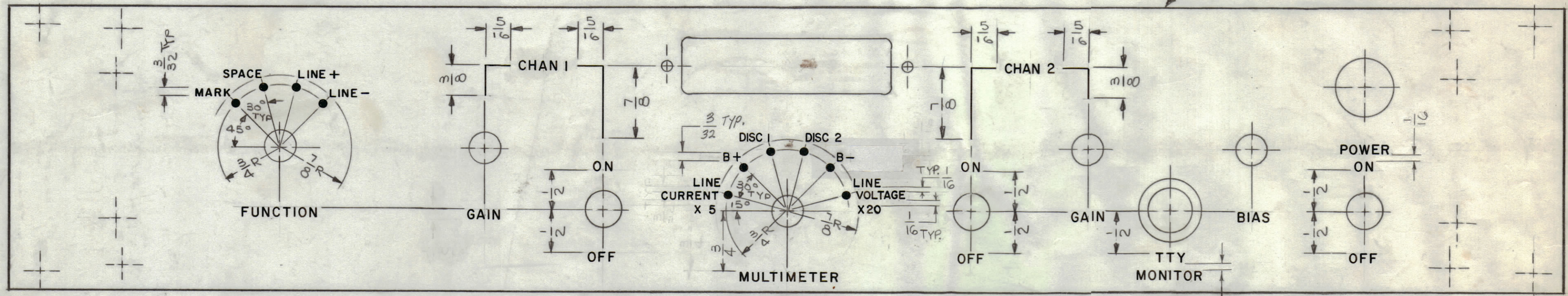

FRONT OF PANEL (ENGRAVING)

HEIGHT OF LETTER	DEPTH OF STROKE	WIDTH OF STROKE
1/8	.010	.020
3/32	.010	.015
LINES	.010	.015
DOTS	.010	1/16 DIA

- UNLESS OTHERWISE SPECIFIED
- 1- ENGRAVING AS PER TMC SPEC S566.
 - 2- ALL LETTER GROUPS TO BE CENTERED ON HOLES.
 - 3- ALL LETTERS, LINES & DOTS TO BE WHITE FILLED.
 - 4- ALL LETTERS TO BE 1/8 HIGH GOTHIC.

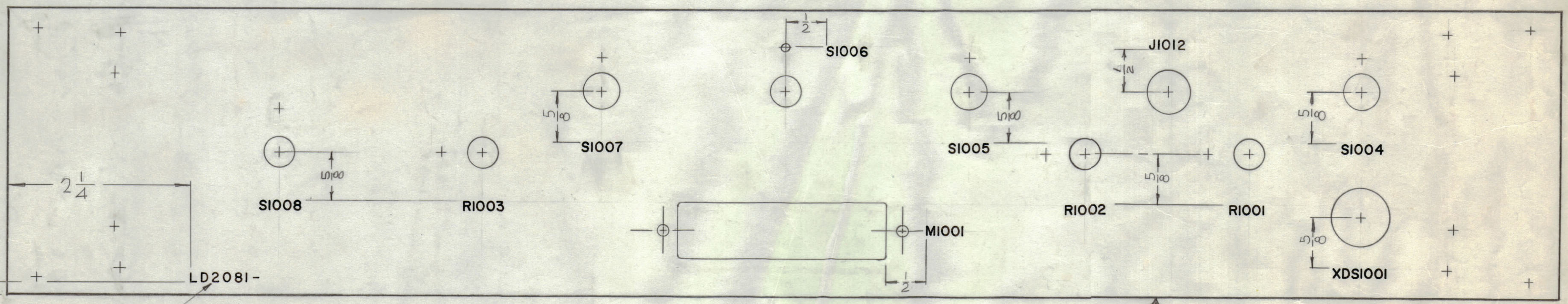

REAR OF PANEL (MARKING)

MARK TMC PT/NO WITH LATEST REV. LETTER

- ~ NOTE ~
- 1- MARKING PROCESS: AS PER TMC SPEC S727.
 - 2- LETTERING: 1/8 HIGH BLACK GOTHIC, LOCATED AS SHOWN.
 - 3 ALL LETTER GROUPS TO BE CENTERED ON HOLES, CUTOUTS OR INDICATING LINES

REF: MS 4924

REQ'D	ITEM	PART NUMBER	DESCRIPTION	SYMBOL
DUDDLES LIST OF MATERIAL				
MATERIAL		THE TECHNICAL MATERIEL CORP. MAMARONECK, NEW YORK		
FINISH		TITLE MARKING - PANEL, FRONT		
UNLESS OTHERWISE SPECIFIED DIMENSIONS ARE IN INCHES AND INCLUDE CHEMICALLY APPLIED OR PLATED FINISHES		DRAWN J. LESHINSKI	DATE 5/2/66	FINAL APPROVAL [Signature]
DECIMALS .X ± .05 .XX ± .01 .XXX ± .005		CHECKED [Signature]	DATE 7-23-66	DATE [Signature]
TOLERANCES FRACTIONS ± 1/64 ANGLES ± 0° 30'		ELECT. DES. MECH. DES.	DATE DATE	DATE DATE
THE CONTENTS OF THIS DRAWING ARE THE EXCLUSIVE PROPERTY OF THE TECHNICAL MATERIEL CORP. ITS UNAUTHORIZED USE OR REPRODUCTION IN WHOLE OR IN PART IS STRICTLY FORBIDDEN.				LD 2081-Ø

1	CFA-2	A5522
Q'TY./UNIT	MODEL USED ON	ASS'Y. NO.
SCALE	CODE	
1/1		

NOTES

LD 2081-Ø