

REVISIONS						
SYM	ZONE	DESCRIPTION	DATE	E.M.N.NO.	DRAFT	CHKD APPD
X		EXPERIMENTAL RELEASE	9.19.66	-	uw	
Ø		ORIGINAL RELEASE FOR PRODUCTION	4.4.67		R.G.	
A		J1 WAS J3 ON BOTTOM VIEW EXT. WAS FRONT INTERIOR WAS REAR LETTERING ON INTERIOR VIEW REVERSED	5.4.67	18167	uw	FE

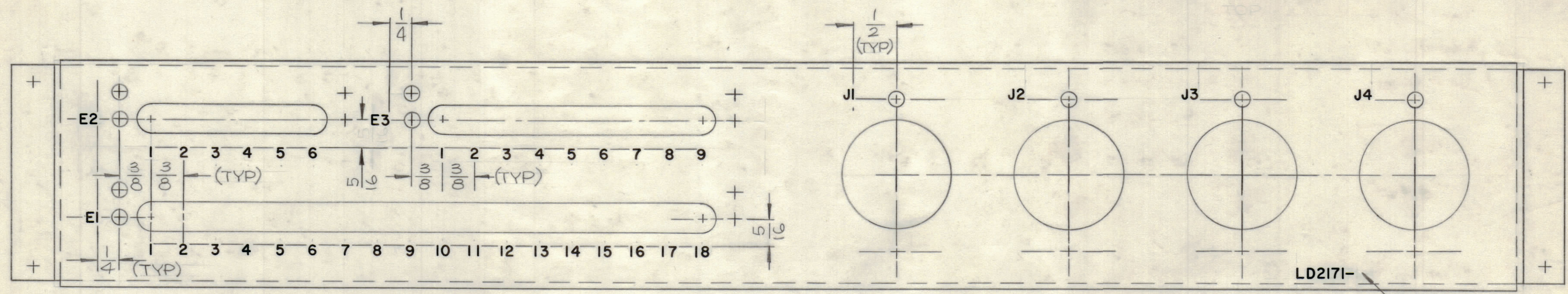

EXTERIOR VIEW

MARK TMC PT/No.
1/8 HIGH GOTHIC W/LATEST
REVISION LETTER

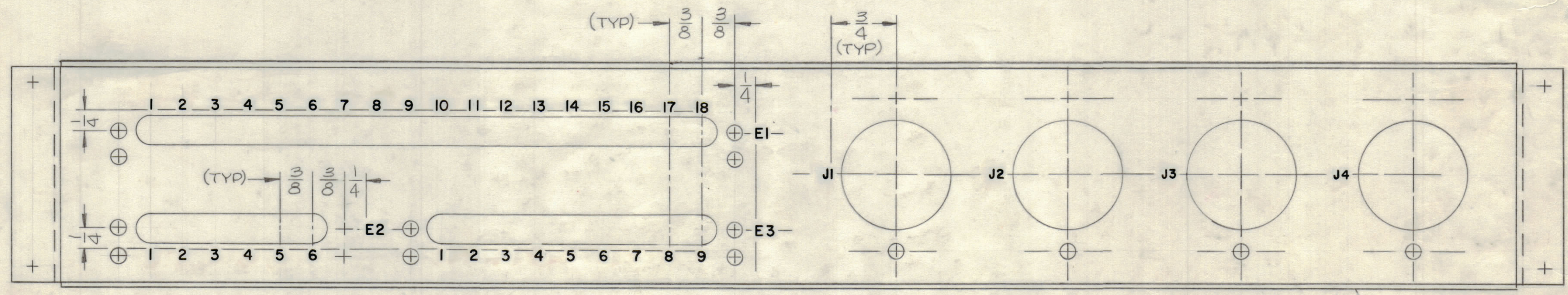

INTERIOR VIEW

UNLESS OTHERWISE SPECIFIED
MARKING PROCESS: AS PER TMC SPECIFICATION S-727.
LETTERING: 1/8 HIGH BLACK GOTHIC, LOCATED AS SHOWN.

REF: MS5093

QTY REQ	ITEM	PART NO.	DESCRIPTION	SYMBOL
EATON BILL OF MATERIAL				
FINAL APPROVAL <i>[Signature]</i>		DATE 4/4/67	THE TECHNICAL MATERIEL CORP. MAMARONECK, NEW YORK	
MECH. DES.		DATE		
ELECT. DES.		DATE	MARKING - CHASSIS, COMPONENT MTG. AX658	
CHECKED <i>[Signature]</i>		DATE		
DRAWN W. WILLIAMS		DATE 9.19.66	CODE 82679	SIZE C
MATERIAL //		APPROVED FOR	DWG. NO. LD2171	ISSUE A
FINISH //		CONTRACT NO.	SCALE MPL 1/100	SHEET OF

MAXIMUM ALLOWABLE TOLERANCES HAVE BEEN DETERMINED AND ANY DEVIATIONS WILL BE CAUSE FOR REJECTION.