

LD-450

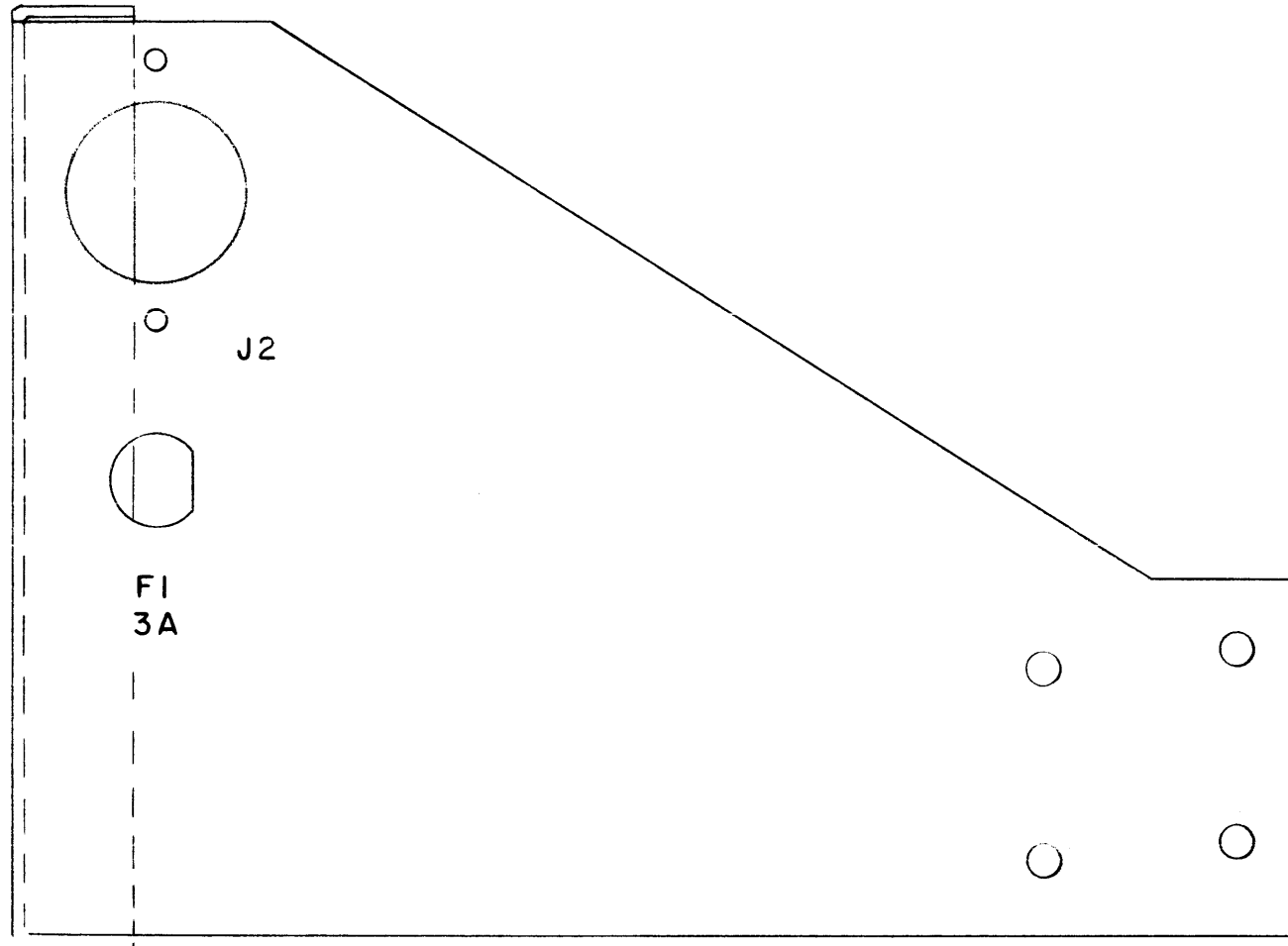

DO NOT TO REPRODUCE OR REUSE THIS DRAWING
 THE TECHNICAL MATERIEL CORPORATION claims proprietary right in the material disclosed hereon. This drawing is issued in confidence for engineering information only and may not be reproduced or used to manufacture anything shown hereon without permission from THE TECHNICAL MATERIEL CORPORATION to the user. This drawing is loaned for mutual assistance and is subject to recall at any time.

Property of:
 THE TECHNICAL MATERIEL CORPORATION
 MAMARONECK, NEW YORK

Lettering 1/8 High black Gothic

Ref-(B)MS-1347

ISSUE	ITEM	CHANGED FROM	DATE	CH. NO.	DRAFTS	CHECKER	ENG. APP.
TOLERANCES			SCALE:		CN 450		
DEC. DIM. ±			MAXIMUM ALLOWABLE TOLERANCES HAVE BEEN DETERMINED AND ANY DEVIATIONS WILL BE CAUSE FOR REJECTION. REMOVE ALL BURRS AND SHARP EDGES				
FRAC. DIM. ±							
ANGULAR DIM. ±							

1	MSR-3			9-19-58
REQ. PER UNIT	MODEL	PROJECT NO.	ASS'Y. NO.	DATE
USED ON				

REQ. ITEM	PART NO.	DESCRIPTION	SYMBOL
		THE TECHNICAL MATERIEL CORP. MAMARONECK, NEW YORK	
STOCK SIZE		LETTERING, RIGHT SIDEPLATE	
MATERIAL		MSR-3	
		10/19/58	<i>[Signature]</i>
TYPE & TEMPER	HEAT TREAT. SPEC.	DRAWN	CHECKED
		<i>[Signature]</i>	
FINISH & SPEC. NO.		ELEC. DES. APP.	MECH. DES. APP.
			LD-450