

FIGURES - 18 POINT ALTERNATE BLACK GOTHIC #2
BACKGROUND - WHITE

REQ. PER UNIT	USED ON			LD615 ϕ
	MODEL	ASS'Y. NO.	DATE	
	GPT-10K			

SPACING - DOUBLE FIGURES 1/32 APART.
SINGLE FIGURES CENTERED
ON 36° ϕ -

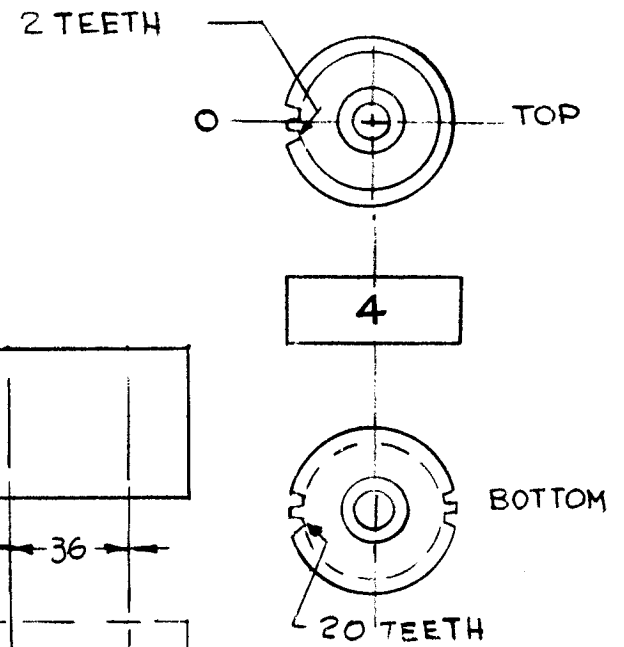
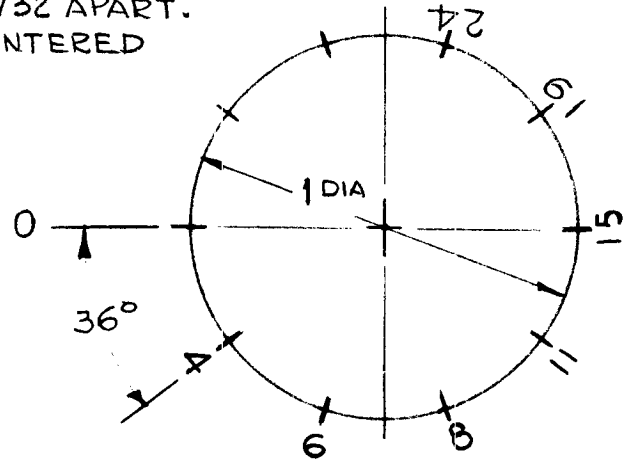

TOP
↑
↓
BOTTOM

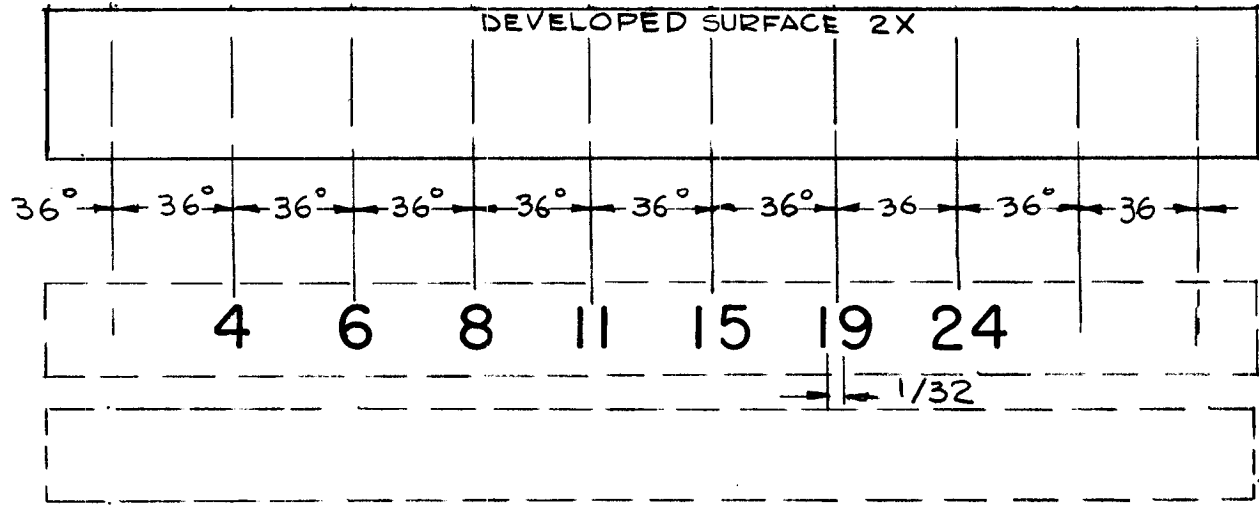

REF: { CY106
LD616

LD616 FOR REF. ONLY
ENG 1-1378-1

REQ.	ITEM	PART NO.	BUDETTI	DESCRIPTION	SYMBOL
				THE TECHNICAL MATERIEL CORP. MAMARONECK. NEW YORK	
				MARKING, WHEEL 1 & 2	
				(CY 106)	
			G.D.L.	QCS	M. May 8/1/62
			DRAWN	CHECKED	FINAL APPROVAL
					LD615 ϕ