

REQ. PER UNIT	USED ON			LD-713
	MODEL	ASS'Y. NO.	DATE	
	1	GPT-40K	AP-10Z	

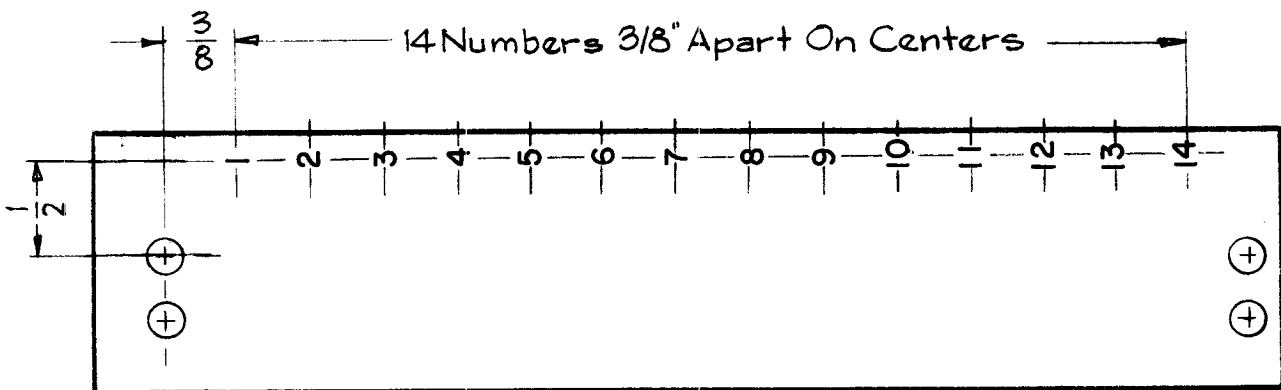

MARKING PROCESS: AS PER TMC SPEC S-727.  
 LETTERING 1/8 HIGH BLACK GOTHIC

Ref: (1) PX-535

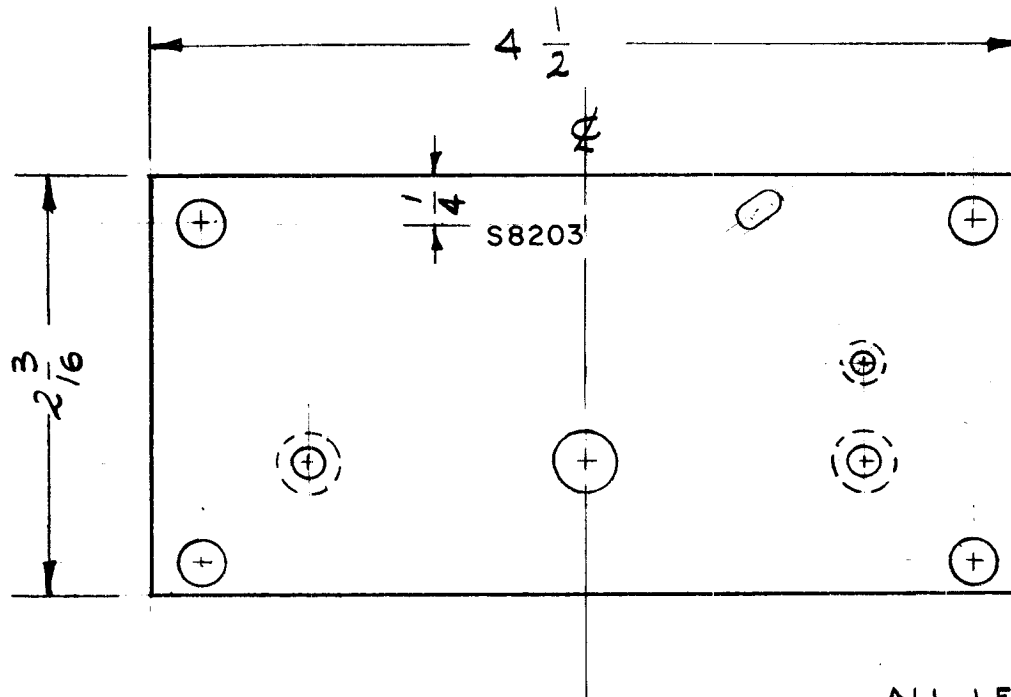

REQ.	ITEM	PART NO.	DESCRIPTION	SYMBOL											
			THE TECHNICAL MATERIEL CORP. MAMARONECK, NEW YORK												
			LETTERING, INSULATOR, TERMINAL STRIP												
ISSUE	ITEM	CHANGED FROM	DATE	CH. NO.	DRAFTS	CHECKER	ENG. APP.	MATERIAL							
TOLERANCES			SCALE:							<i>Dama</i>	<i>HJ</i>	<i>JS</i>			
DEC. DIM. ±			MAXIMUM ALLOWABLE TOLERANCES HAVE BEEN DETERMINED AND ANY DEVIATIONS WILL BE CAUSE FOR REJECTION: REMOVE ALL BURRS AND SHARP EDGES					TYPE & TEMPER	HEAT TREAT. SPEC.	DRAWN	CHECKED	FINAL APPROVAL			
FRAC. DIM. ±															
ANGULAR DIM. ±															
								FINISH & SPEC. NO.	ELEC. DES. APP	MECH. DES. APP	LD-713				

REQ. PER UNIT	USED ON			LD-723	A
	MODEL	ASS'Y. NO.	DATE		
1	AT-101	GPT-40K	4-8-60		



ALL LETTERING 1/8 HIGH, BLACK GOTHIC.  
MARKING PROCESS: AS PER TMC SPECIFICATION S-727.

REF: MS-2124

ISSUE	ITEM	CHANGED FROM	DATE	CH. NO.	DRAFTS	CHECKER	ENG. APP.	REQ.	ITEM	PART NO.	DESCRIPTION	SYMBOL	
											THE TECHNICAL MATERIEL CORP. MAMARONECK, NEW YORK	LD-723	
													PLATE, DETENT MOUNTING
A	1	SEE MS-2124 REV "A"	3-11-63	8478	RC								
TOLERANCES			SCALE: FULL					MATERIAL		DRAWN		FINAL APPROVAL	
DEC. DIM. ± FRAC. DIM. ± ANGULAR DIM. ±			MAXIMUM ALLOWABLE TOLERANCES HAVE BEEN DETERMINED AND ANY DEVIATIONS WILL BE CAUSE FOR REJECTION. REMOVE ALL BURRS AND SHARP EDGES					TYPE & TEMPER		HEATTREAT. SPEC.		ELEC. DES. APP MECH. DES. APP	
										  			
												LD-723	
												A	

REQ. PER UNIT	USED ON			LD-731	B
	MODEL	ASSY. NO.	DATE		
	CSS-1		4-25-60		

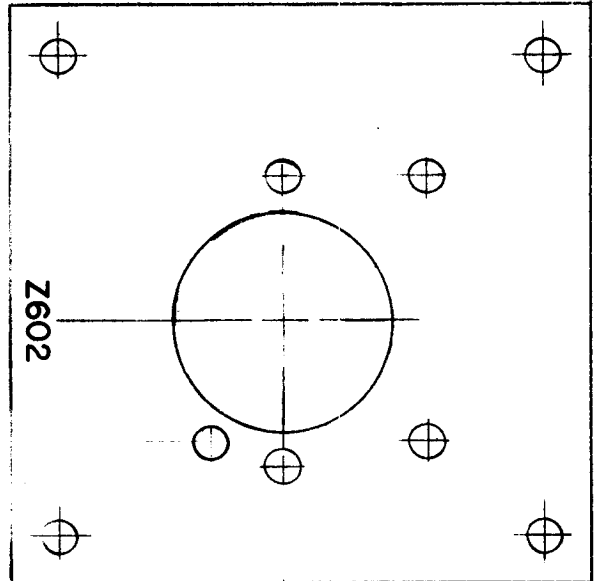

MARKING PROCESS: AS PER TMC SPECIFICATION S-727.  
 LETTERING: 1/8 HIGH BLACK, GOTHIC  
 LOCATED AS SHOWN.

REF: MS-2204

							REQ.	ITEM	PART NO.	DESCRIPTION	SYMBOL			
									THE TECHNICAL MATERIEL CORP. MAMARONECK, NEW YORK					
B	1	Z602 Relocated	12-11-61	6025	L.G.	<i>[Signature]</i>			LETTERING, MOUNTING PLATE					
A	1	Pictorial Clarified	5/24/60	2327	<i>[Signature]</i>	<i>[Signature]</i>								
ISSUE	ITEM	CHANGED FROM	DATE	CH. NO.	DRAFTS	CHECKER	ENG. APP.							
TOLERANCES			SCALE:											
DEC. DIM. ± FRAC. DIM. ± ANGULAR DIM. ±			MAXIMUM ALLOWABLE TOLERANCES HAVE BEEN DETERMINED AND ANY DEVIATIONS WILL BE CAUSE FOR REJECTION. REMOVE ALL BURRS AND SHARP EDGES						TYPE & TEMPER	HEAT TREAT. SPEC.	DRAWN	CHECKED	FINAL APPROVAL	
							FINISH & SPEC. NO.		ELEC. DES. APP		MECH. DES. APP		LD-731	B









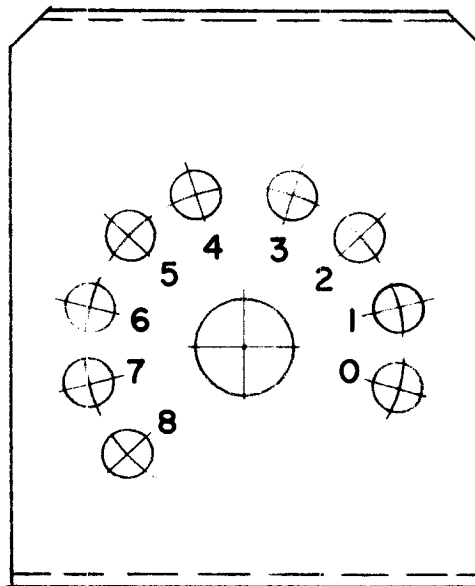

REQ. PER UNIT	USED ON			LD-749
	MODEL	ASS'Y. NO.	DATE	
1	CLL-1		6-16-60	

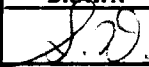

LETTERING 1/8 HIGH BLACK GOTHIC.  
MARKING PROCESS: AS PER TMC SPECIFICATION S-727

REF: MS-2219 (2)

ISSUE	ITEM	CHANGED FROM	DATE	CH. NO.	DRAFTS	CHECKER	ENG. APP.	REQ.	ITEM	PART NO.	DESCRIPTION	SYMBOL	
											<b>THE TECHNICAL MATERIEL CORP.</b> MAMARONECK, NEW YORK <i>LETTERING, BRACKET, RIGHT SIDE</i> CAPACITOR MOUNTING		
										STOCK SIZE			
										MATERIAL			
											  		
											DRAWN 	CHECKED 	FINAL APPROVAL LD-749
										FINISH & SPEC. NO.	ELEC. DES. APP	MECH. DES. APP	

REQ. PER UNIT	USED ON			LD-750
	MODEL	ASS'Y. NO.	DATE	
1	CLL-1		6-16-60	

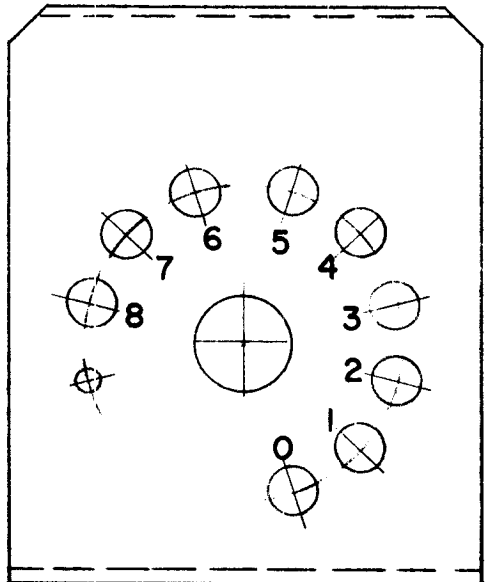

LETTERING 1/8 HIGH BLACK GOTHIC.  
 MARKING PROCESS: AS PER T M C SPECIFICATION S-727.

REF: MS-2220 (2)

ISSUE	ITEM	CHANGED FROM	DATE	CH. NO.	DRAFTS	CHECKER	ENG. APP.	REQ.	ITEM	PART NO.	DESCRIPTION	SYMBOL	
											THE TECHNICAL MATERIEL CORP. MAMARONECK, NEW YORK <b>LETTERING, BRACKET, LEFT SIDE</b> <b>CAPACITOR MOUNTING</b>		
										STOCK SIZE			
										MATERIAL			
TOLERANCES			SCALE:										
DEC. DIM. ± FRAC. DIM. ± ANGULAR DIM. ±			MAXIMUM ALLOWABLE TOLERANCES HAVE BEEN DETERMINED AND ANY DEVIATIONS WILL BE CAUSE FOR REJECTION. REMOVE ALL BURRS AND SHARP EDGES					TYPE & TEMPER	HEAT TREAT. SPEC.	DRAWN	CHECKED	FINAL APPR VAL	
								FINISH & SPEC. NO.		ELEC. DES. APP MECH. DES. APP		LD-750	



REQ. PER UNIT	USED ON			LD-762	A
	MODEL	ASS'Y. NO.	DATE		
1	AFC-1		8-2-60		

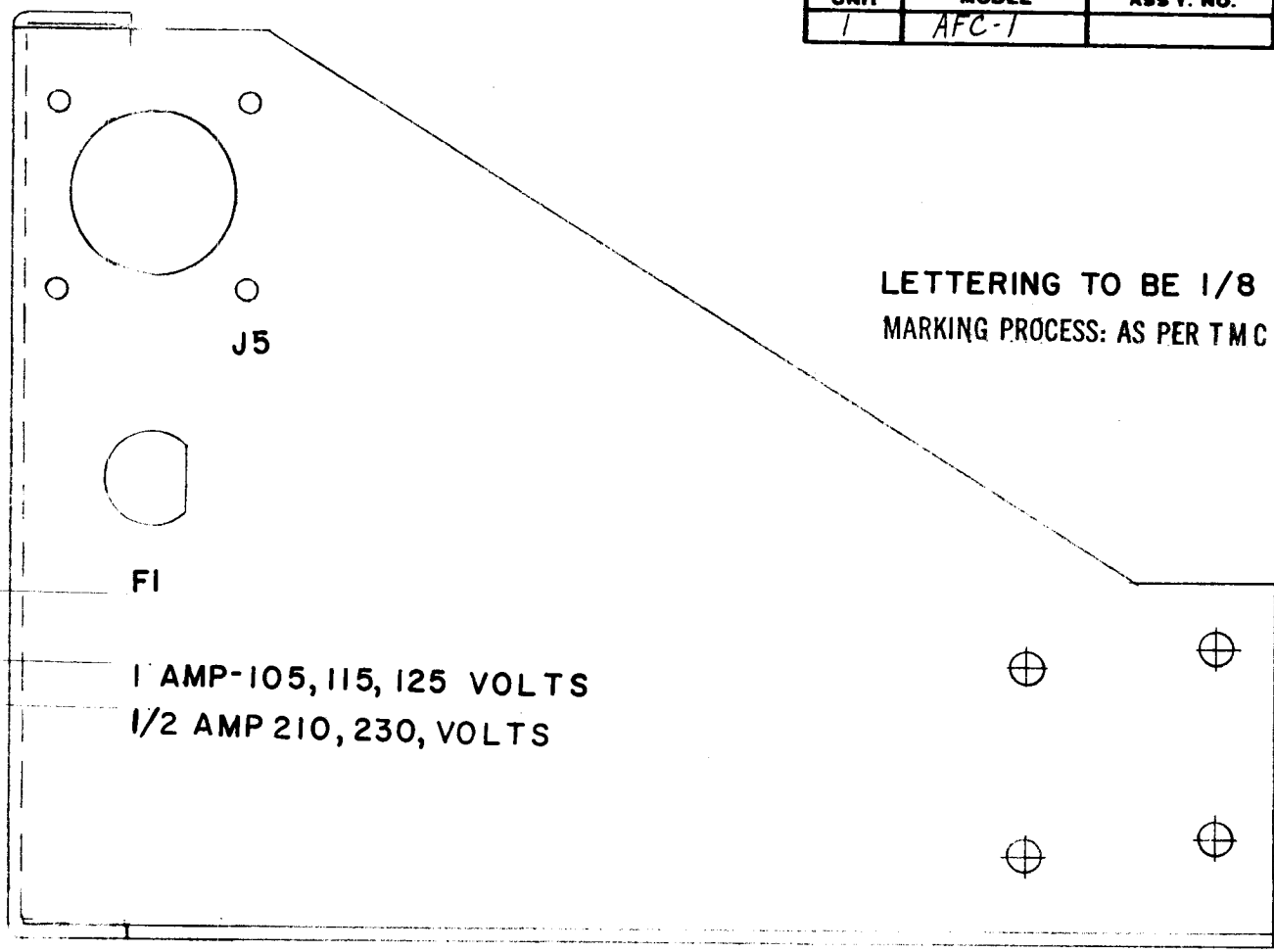

LETTERING TO BE 1/8 HIGH BLACK GOTHIC.  
 MARKING PROCESS: AS PER T M C SPECIFICATION S-727.

OUTSIDE, REAR VIEW

REF: MS-2340

							REQ.	ITEM	PART NO.	DESCRIPTION			SYMBOL		
										THE TECHNICAL MATERIEL CORP. MAMARONECK, NEW YORK					
										LETTERING, RIGHT SIDE PLATE (AFC-1)					
										DRAWN			CHECKED	FINAL APPROVAL	
										3Fm				LD-762	A
										ELEC. DES. APP			MECH. DES. APP		

ISSUE	ITEM	CHANGED FROM	DATE	CH. NO.	DRAFTS	CHECKER	ENG. APP.
A	3	1A DELETED	8/18/60	2830	RU.	QCB	HW
	2	1 AMP-105, 115, 125V ADDED					
	1	1/2 AMP-210, 230V ADDED					

  

TOLERANCES		SCALE:
DEC. DIM. ±	MAXIMUM ALLOWABLE TOLERANCES HAVE BEEN DETERMINED AND ANY DEVIATIONS WILL BE CAUSE FOR REJECTION.	
FRAC. DIM. ±	REMOVE ALL BURRS AND SHARP EDGES	
ANGULAR DIM. ±		

REQ. PER. UNIT	USED ON			LD-763	A
	MODEL	ASS'Y. NO.	DATE		
1	AFC-1		8-2-60		

MARKING PROCESS: AS PER TMC SPECIFICATION S-727

LETTERING TO BE 1/8 HIGH BLACK GOTHIC.

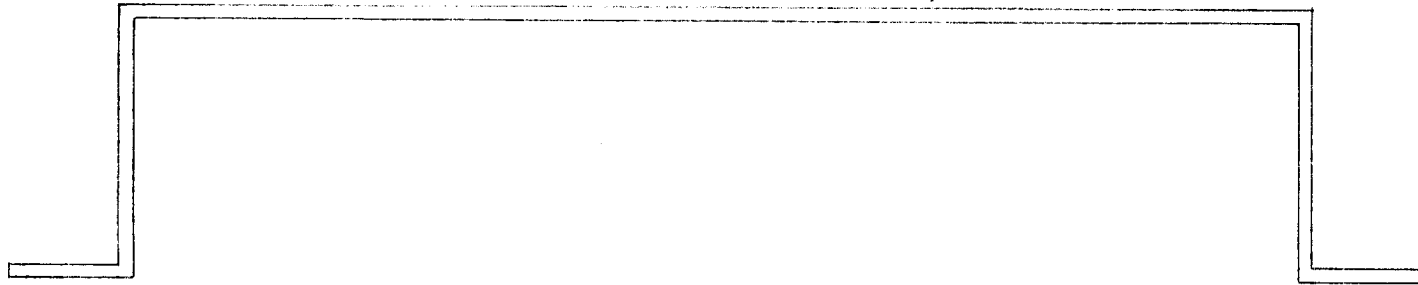
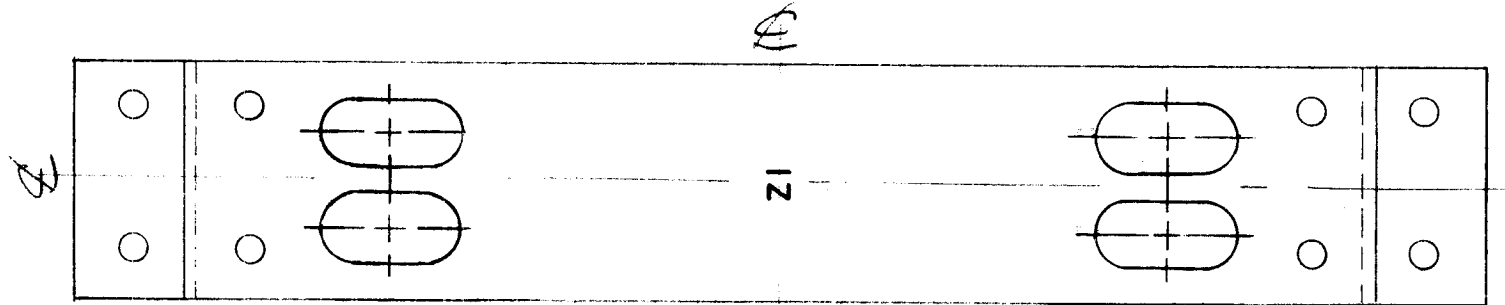

REF: MS-2332(1)

ISSUE	ITEM	CHANGED FROM	DATE	CH. NO.	DRAFTS	CHECKER	ENG. APP.	REQ.	ITEM	PART NO.	DESCRIPTION	SYMBOL	
											THE TECHNICAL MATERIEL CORP. MAMARONECK, NEW YORK		
											LETTERING BRACKET, 17K.C.		
											FILTER		
A	1	STAMPING DELETED 1-2-3-4	8/18/60	2796	RU	JR	JM				  		
TOLERANCES			SCALE:					TYPE & TEMPER	HEAT TREAT. SPEC.	DRAWN	CHECKED	FINAL APPROVAL	
DEC. DIM. ± FRAC. DIM. ± ANGULAR DIM. ±			MAXIMUM ALLOWABLE TOLERANCES HAVE BEEN DETERMINED AND ANY DEVIATIONS WILL BE CAUSE FOR REJECTION. REMOVE ALL BURRS AND SHARP EDGES							SFM		LD-763	A
								FINISH & SPEC. NO.		ELEC. DES. APP		MECH. DES. APP	

REQ. PER. UNIT	USED ON			LD-773
	MODEL	A SY. NO.	DATE	
1	CLL-1		8-16-60	

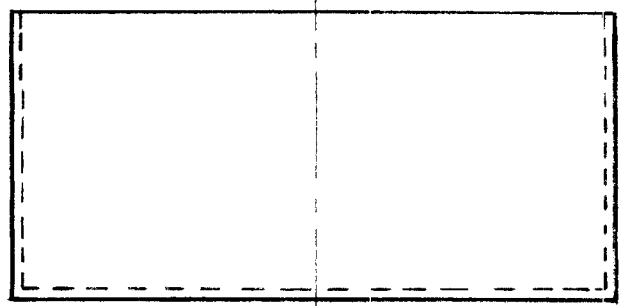

NOTE:  
LETTERING 1/4 HIGH  
BLACK GOTHIC

MARKING PROCESS: AS PER T M C SPECIFICATION S-727.

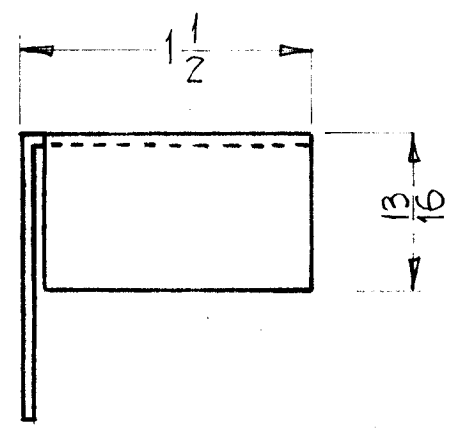
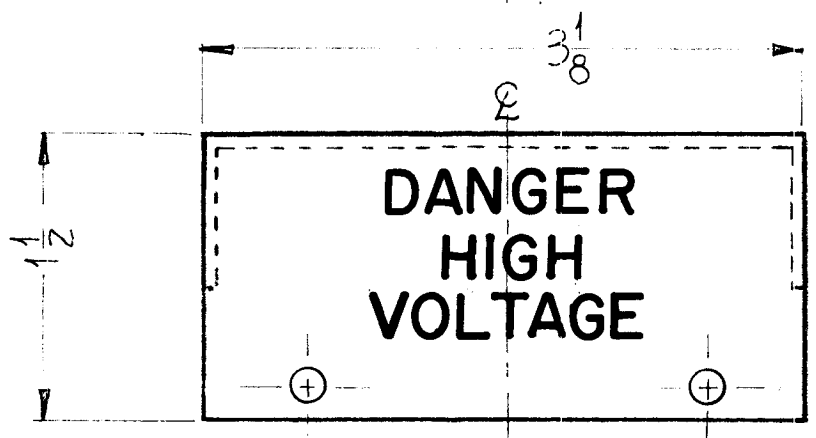

REF. MS-2216 (1)

								REQ.	ITEM	PART NO.	DESCRIPTION		SYMBOL
										THE TECHNICAL MATERIEL CORP.			
										MAMARONECK, NEW YORK			
										COVER BOARD			
										STAMPING, TERMINAL ELEMENT			
ISSUE	ITEM	CHANGED FROM	DATE	CH. NO.	DRAFTS	CHECKER	ENG. APP.			DRAWN	CHECKED	FINAL APPROVAL	
TOLERANCES			SCALE:							DRAWN		FINAL APPROVAL	
DEC. DIM. ±			MAXIMUM ALLOWABLE TOLERANCES HAVE BEEN DETERMINED AND ANY DEVIATIONS WILL BE CAUSE FOR REJECTION.					TYPE & TEMPER		HEAT TREAT. SPEC.		ELEC. DES. APP	
FRAC. DIM. ±			REMOVE ALL BURRS AND SHARP EDGES									MECH. DES. APP	
ANGULAR DIM. ±								FINISH & SPEC. NO.				LD-773	

REQ. PER. UNIT	USED ON			LD-784
	MODEL	ASSY. NO.	DATE	
1	GPT-40K	AX209	9-28-60	

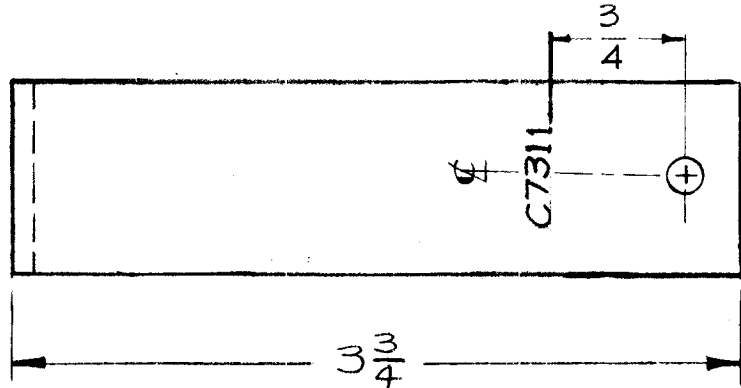
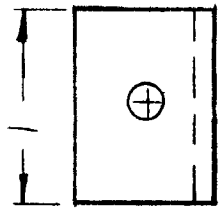

REAR VIEW SHOWN

MARKING PROCESS: AS PER TMC SPECIFICATION S-727

1/8 HIGH BLACK GOTHIC LETTERING

REF MS-2202 (REVERSED)

							REQ.	ITEM	PART NO.	DESCRIPTION		SYMBOL	
										THE TECHNICAL MATERIEL CORP.			
										MAMARONECK, NEW YORK			
										LETTERING, SUPPORT			
										COIL			
ISSUE	ITEM	CHANGED FROM	DATE	CH. NO.	DRAFTS	CHECKER	ENG. APP.			Rurro	JCBile	DS	
TOLERANCES			SCALE: (DO NOT SCALE)								FINAL APPROVAL		
DEC. DIM. ±			MAXIMUM ALLOWABLE TOLERANCES HAVE BEEN DETERMINED AND ANY DEVIATIONS WILL BE CAUSE FOR REJECTION. REMOVE ALL BURRS AND SHARP EDGES				TYPE & TEMPER		HEATTREAT. SPEC.		DRAWN		CHECKED
FRAC. DIM. ± 1/64							FINISH & SPEC. NO.		ELEC. DES. APP		MECH. DES. APP		LD-784
ANGULAR DIM. ±													

REQ. PER UNIT	USED ON			LD-785	B
	MODEL	ASSY. NO.	DATE		
1	GPT-40K	AX-209	9-28-60		

LETTERING TO BE  
1/8 HIGH BLACK GOTHIC

MARKING PROCESS: AS PER TMC SPECIFICATION S-727

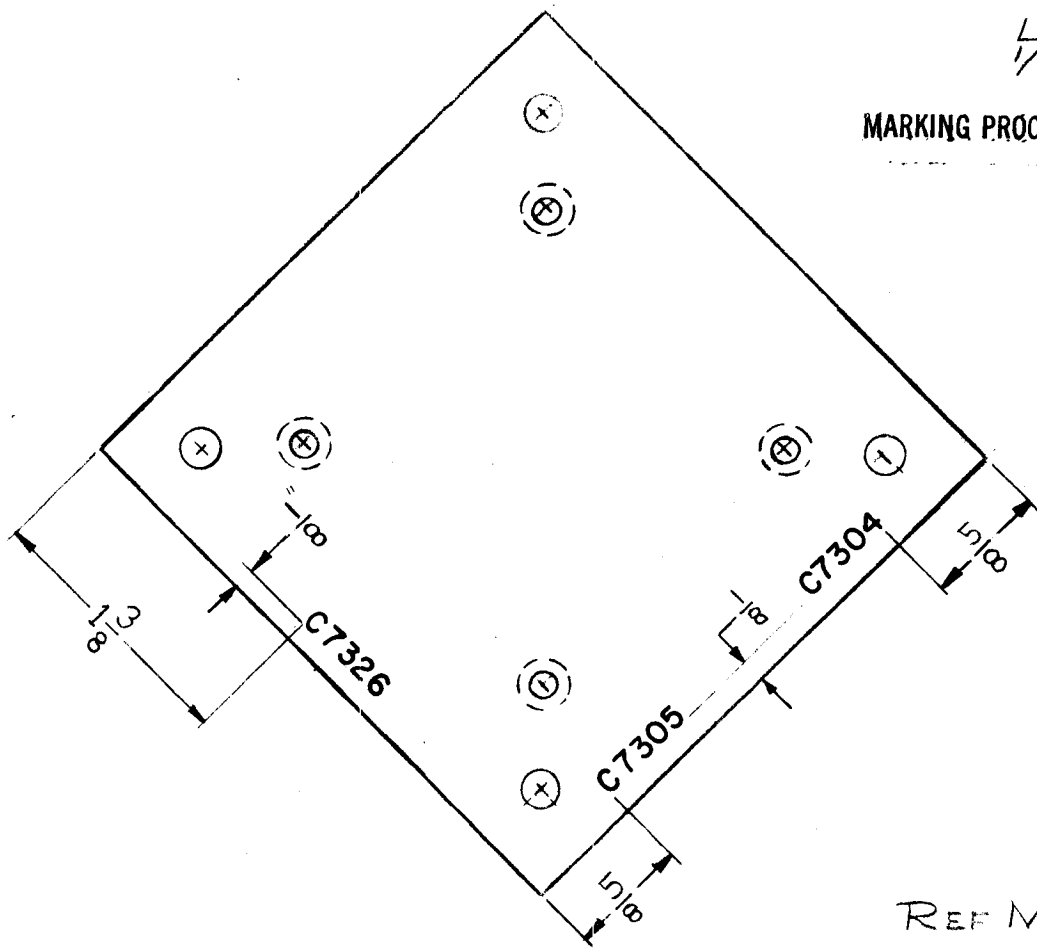

REF MS-2224(1)

								REQ.	ITEM	PART NO.	DESCRIPTION	SYMBOL	
B	2	VIEW OF PLATE REVERSED	9-22-61	5604	IL	AB				THE TECHNICAL MATERIEL CORP. MAMARONECK, NEW YORK			
	1	C7304, C7305, C7326 RELOCATED								LETTERING, PLATE, CAPACITOR MOUNT			
A	1	C7304, RELOCATED	10/18/60	3227	RH	JCB				Ruro JCB DB			
ISSUE	ITEM	CHANGED FROM	DATE	CH. NO.	DRAFTS	CHECKER	ENG. APP.						
TOLERANCES			SCALE: (DO NOT SCALE)										
DEC. DIM. ± FRAC. DIM. ± 1/64 ANGULAR DIM. ±			MAXIMUM ALLOWABLE TOLERANCES HAVE BEEN DETERMINED AND ANY DEVIATIONS WILL BE CAUSE FOR REJECTION. REMOVE ALL BURRS AND SHARP EDGES										
								TYPE & TEMPER	HEAT TREAT. SPEC.	DRAWN	CHECKED	FINAL APPROVAL	
								FINISH & SPEC. NO.	ELEC. DES. APP	MECH. DES. APP	LD-785	B	

REQ. PER. UNIT	USED ON			LD-786	A
	MODEL	ASS'Y. NO.	DATE		
1	AX-209	40K	9-29-60		

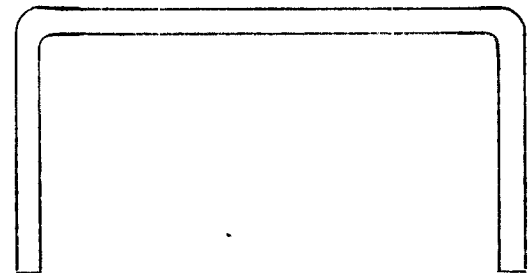

LETTERING TO BE 1/8 HIGH  
BLACK GOTHIC  
MARKING PROCESS: AS PER TMC SPECIFICATION S-727

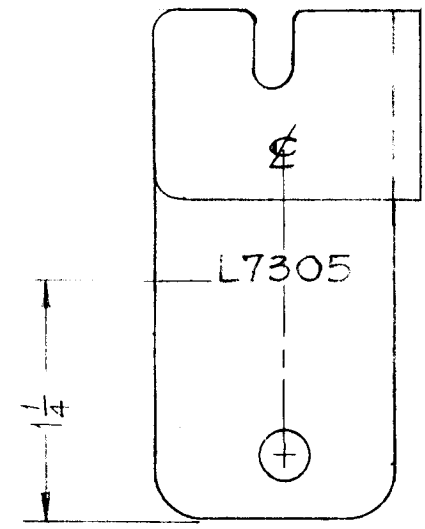
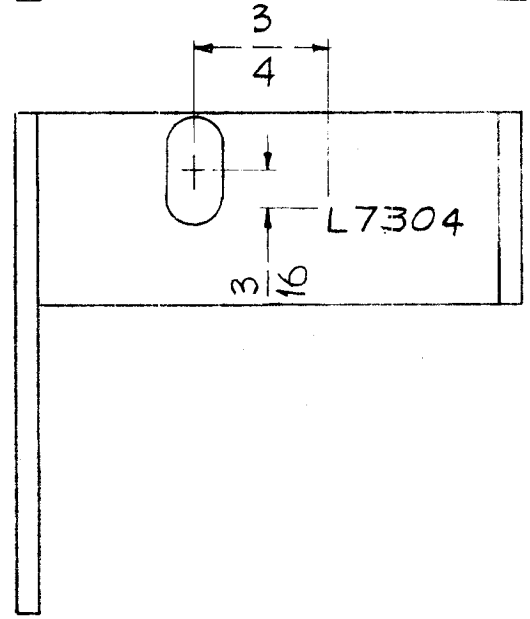

REF - MS - 2090 (1)

								REQ.	ITEM	PART NO.	DESCRIPTION			SYMBOL			
											THE TECHNICAL MATERIEL CORP.						
											MAMARONECK, NEW YORK						
											LETTERING, BRACKET,						
											CHOKE						
A	2	SEE EMN*10878	2-10-64	10878	A.M.	TR											
ISSUE	ITEM	CHANGED FROM	DATE	CH. NO.	DRAFTS	CHECKER	ENG. APP.	MATERIAL									
TOLERANCES			SCALE: FULL (NO HOT SCALE)					TYPE & TEMPER			HEATTREAT. SPEC.	DRAWN	CHECKED	FINAL APPROVAL			
DEC. DIM. ±			MAXIMUM ALLOWABLE TOLERANCES HAVE BEEN DETERMINED AND ANY DEVIATIONS WILL BE CAUSE FOR REJECTION. REMOVE ALL BURRS AND SHARP EDGES					FINISH & SPEC. NO.			ELEC. DES. APP	MECH. DES. APP	LD-786	A			
FRAC. DIM. ± 1/64																	
ANGULAR DIM. ±																	

REQ. PER. UNIT	USED ON			LD-790 A
	MODEL	ASSY. NO.	DATE	
	GPT-40K	AX209	10-3-60	

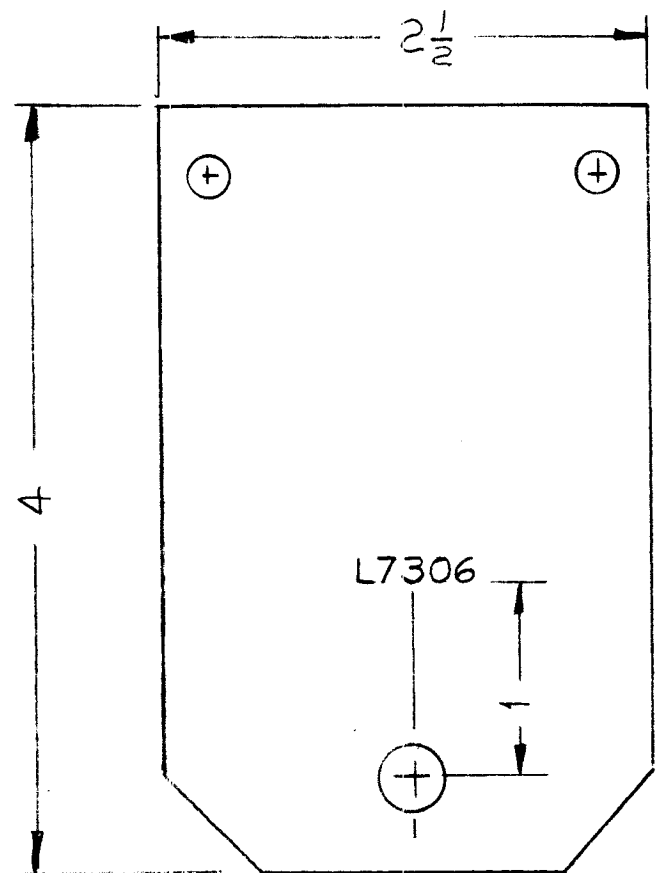

MARKING PROCESS:  
AS PER TMC SPEC S-727.  
LETTERING TO BE 1/8  
HIGH BLACK GOTHIC

REF-PX-551

							REQ.	ITEM	PART NO.	DESCRIPTION	SYMBOL	
										THE TECHNICAL MATERIEL CORP.		
										MAMARONECK, NEW YORK		
										LETTERING, SUPPORT,		
										COIL & CAPACITOR		
A	1	Lettering Was White Gothic	4-25-62	6639	EL	AD						
ISSUE ITEM	CHANGED FROM		DATE	CH. NO.	DRAFTS	CHECKER	ENG. APP.	MATERIAL				
TOLERANCES			SCALE: (DO NOT SCALE)				TYPE & TEMPER		HEATTREAT. SPEC.	DRAWN	CHECKED	FINAL APPROVAL
DEC. DIM. ±			MAXIMUM ALLOWABLE TOLERANCES HAVE BEEN DETERMINED AND ANY DEVIATIONS WILL BE CAUSE FOR REJECTION. REMOVE ALL BURRS AND SHARP EDGES									LD-790 A
FRAC. DIM. ± 1/64							FINISH & SPEC. NO.		ELEC. DES. APP	MECH. DES. APP		
ANGULAR DIM. ±												

REQ. PER UNIT	USED ON		DATE	LD-792
	MODEL	ASSY. NO.		
2	GPT-40K	AX 209	9-28-60	

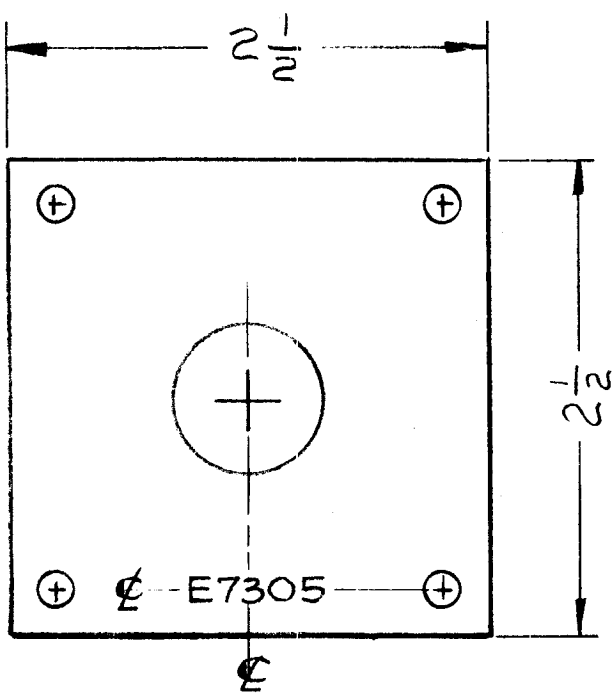

MARKING PROCESS:  
AS PER TMC SPEC S-727.  
LETTERING TO BE 1/8 HIGH  
BLACK GOTHIC

PX-555 (1)

ISSUE	ITEM	CHANGED FROM	DATE	CH. NO.	DRAFTS	CHECKER	ENG. APP.	REQ.	ITEM	PART NO.	DESCRIPTION	SYMBOL	
											THE TECHNICAL MATERIEL CORP. MAMARONECK, NEW YORK LETTERING, PLATE, FEED THRU.		
										STOCK SIZE			
										MATERIAL			
											Ruzzo J. Buile J. B.		
											DRAWN CHECKED W.C.	FINAL APPROVAL LD-792	
											ELEC. DES. APP	MECH. DE . APP	