

NOTE:  
STAMP OPPOSITE SIDE IDENTICAL.

REQ. PER. UNIT	USED ON			LD-889
	MODEL	ASS'Y. NO.	DATE	
1	RAK-11B		1-23-61	

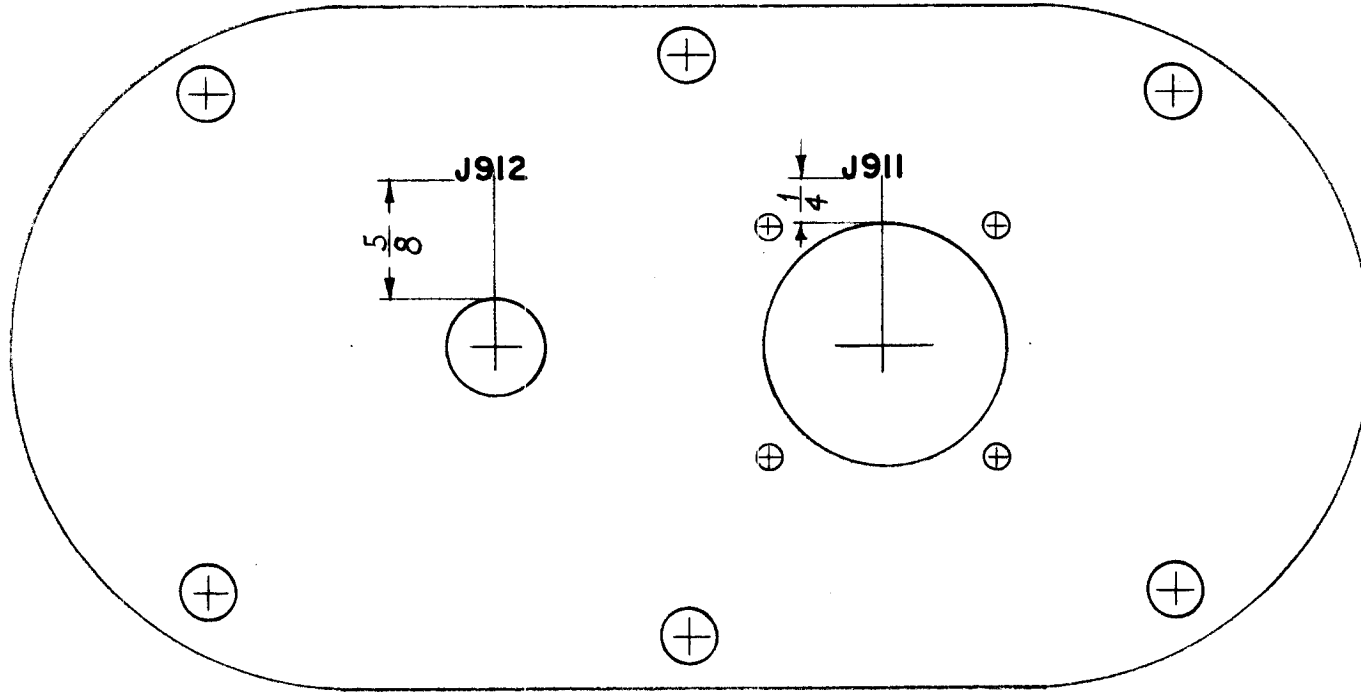

MARKING PROCESS: AS PER TMC SPECIFICATION S-727  
ALL LETTERING 1/8 HIGH WHITE.

REF: MS-2500-S (2)

								REQ.	ITEM	PART NO.	DESCRIPTION		SYMBOL						
										THE TECHNICAL MATERIEL CORP.									
										MAMARONECK, NEW YORK									
										LETTERING, INTERCONNECT									
										CONNECTOR PLATE									
ISSUE	ITEM	CHANGED FROM	DATE	CH. NO.	DRAFTS	CHECKER	ENG. APP.												
TOLERANCES			SCALE:																
DEC. DIM. ±			MAXIMUM ALLOWABLE TOLERANCES HAVE BEEN DETERMINED AND ANY DEVIATIONS WILL BE CAUSE FOR REJECTION. REMOVE ALL BURRS AND SHARP EDGES					TYPE & TEMPER		HEATTREAT. SPEC.		DRAWN		CHECKED		FINAL APPROVAL			
FRAC. DIM. ±																			
ANGULAR DIM. ±																			
								FINISH & SPEC. NO.		ELEC. DES. APP		MECH. DES. APP		LD-889					