

IF IT IS FOUND DESIRABLE TO CHANGE ANY TOLERANCE OR OTHER DETAIL SPECIFIED ON THIS DRAWING NOTIFY THE PURCHASER PROMPTLY.

MAXIMUM ALLOWABLE TOLERANCES HAVE BEEN DETERMINED AND DEVIATIONS WILL BE CAUSE FOR REJECTION. REMOVE ALL BURRS AND SHARP EDGES.

DIMENSIONS IN INCHES UNLESS OTHERWISE SPECIFIED

MS 11256 E

REQ.	ITEM	PART NO.	DESCRIPTION	SYMBOL
------	------	----------	-------------	--------

ISSUE	ITEM	CHANGED FROM	DATE	CH. NO.	DRAFTS	CHECKER	ENG. APP.
B		REVISED / REDRAWN	6/27/72	1198	C.C.	H.C.S.	
C		REV AS PER CEMN	27/08/73	1224	C.C.	H.C.S.	SDW
D		NOTE 3 DELETED	11/17/75	21328	CL		
E		CHANGE ALL DIMS. FROM DEC. TO FRAC. & UPDATED & REVISED	12/28/80	21872	GDL		

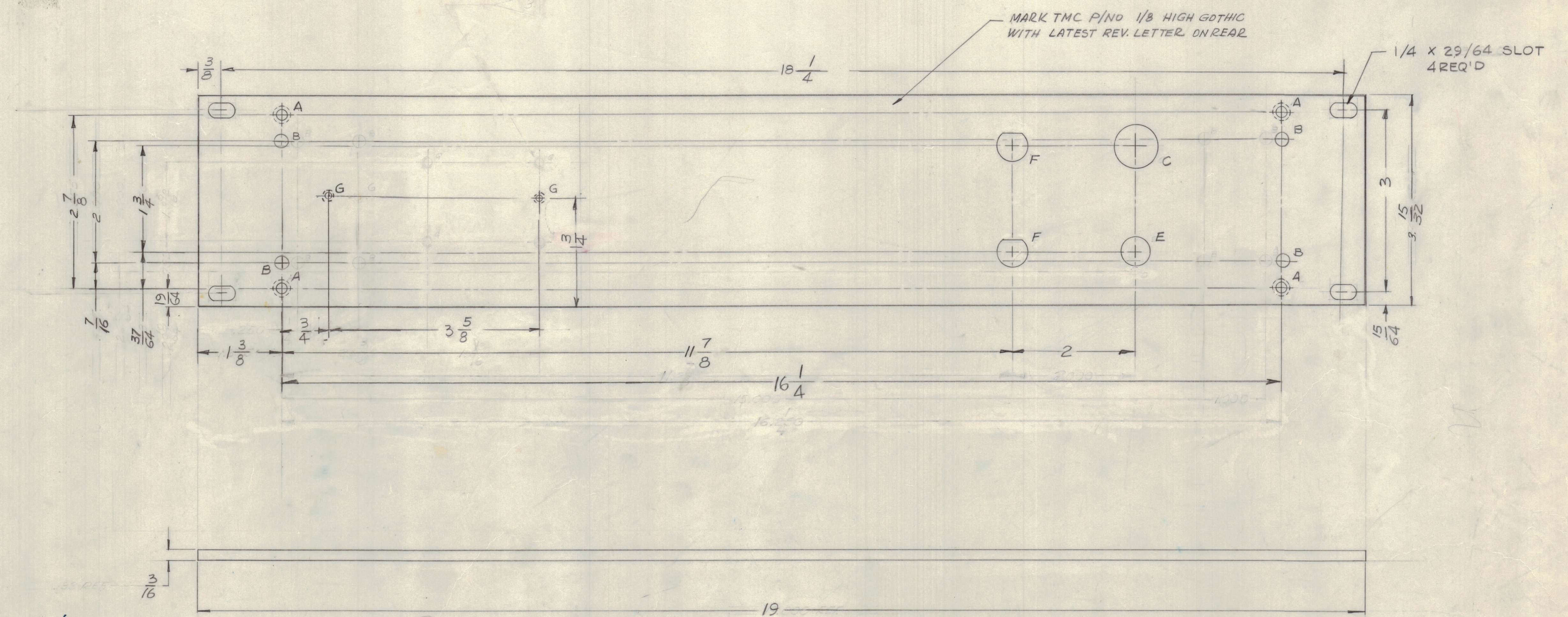

FINISH NOTES:

- S404 - IRIDITE 14-2 AL-COAT.
- S114 - ZINC CHROMATE PRIMER
- S115 - SMOOTH GRAY ENAMEL

FRONT AND EDGES ONLY
OR
PRIME AND PAINT PER CUSTOMER'S SPECIFICATIONS

MACHINING:

- MILL ALL EDGES.
- HOLES MUST BE DRILLED, UNLESS OTHERWISE SPECIFIED.
- LATERAL BOW OF PANEL MUST BE KEPT TO .031 TOLERANCE.
- PANEL MUST BE FREE OF ALL MACHINING MARKS, GOUGES AND SCRATCHES. IF NECESSARY, SAND FRONT OF PANEL WITH NO. 120 GRIT SANDPAPER.

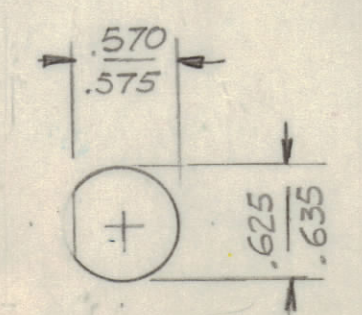

DETAIL "F"

HOLE	DESCRIPTION	QTY
A	.171 DIA., C'SUNK 82° x .281 DIA., BACK FACE	4
B	13/64 DIA.	4
C	.1116	1
D	DELETED	
E	15/32 DIA	1
F	SEE DETAIL	2
G	DRILL .078 (#47) & TAP FOR G-32 TWD	2
H	29/64 X 1/4 SLOT	4

TOLERANCES UNLESS OTHERWISE SPECIFIED	SCALE: 1/1	DRILL PUNCH, COMMERCIAL STOCK SIZES AND MANUFACTURERS TOLERANCES ARE NOT INCLUDED
ALL DEC. DIM ± .05		
OTHERS FRAC. DIM ± .01		
ANGULAR DIM ± 0° 30'		

MODEL	PROJECT NO.	ASSY. NO.	DATE
VMC 8	084/11		OCT 20 th 72

STOCK SIZE		TMC (Canada) LIMITED OTTAWA ONTARIO	
MATERIAL		FRONT PANEL	
WEIGHT PER PC			
TYPE & TEMPER		C.CHARLES	H.C.SCHAFER
DRAWN		ELEC. DES. APP.	MECH. DES. APP.
HEAT TREAT SPEC.		CHECKED	FINAL APPROVAL
FINISH & SPEC. NO.		MS 11256 E	